



Submittal-60K-Ultranixx

Job name:		Submitted by:	
Location:		Submitted to:	
Engineer:		Unit tag:	
Date:		Drawing number:	

Warranty information
 Standard 7 years parts & compressor
 Registered 12 years parts & compressor
 Terms and conditions apply

Type
 Energy Star
 Cold Climate Energy Star

Model numbers
 Indoor: KCAC60HI
 Outdoor: KU60UXO

Capacity range

Output (BTU/H)	Minimum	Rated	Max	Certification		
Cooling:	15200	52000	53100	AHRI NO.	Energy Star	nep
Heating:	14400	54000	54000	217603526	-	

Heating performance				Efficiency Ratings	
Output (BTU/H)	Minimum	Rated	Max	SEER2	
47F (8.3C)	14400	54000	54000	HSPF2	16
17F (-8.3C)	7800	35200	35600	EER2	9
5F (-15C)	18900	40000	40000	COP	9.8
					3.1

Outdoor temperature range			Electrical	
Cooling:	-15-54C	5-129F	Power supply	208-230V/60Hz/1Ph
Heating:	-30-24C	-22-75F	Min/Max voltage	187-253Vac

Condenser specifications			MCA	
Connecting type	Screw Connection		MOP	39A
Pre-charge length	25ft (7.5M)		Power Supply Wire	45A
MIN. Refrigerant Pipe Length	10 ft (3M)		Interconnecting Wire	8/2 AWG
Liquid Pipe Size	3/8in (9.52mm)		18/6AWG or 18/2AWG	

Features		
Gas Pipe Size	3/4in (19mm)	
Max Height Between Indoor/Outdoor	50ft (15M)	
Max. Pipe Length	100ft (30M)	
Refrigerant Type	R-32	
Factory Charge	162oz	
Additional Charge	0.3 oz/ft	
Sound Pressure Level	62dB (A)	



Weight	
Gross weight:	263.5Lbs (119.5Kg)
Net weight:	241.4Lbs (109.5Kg)



Outdoor unit Dimensions

KU60UXO

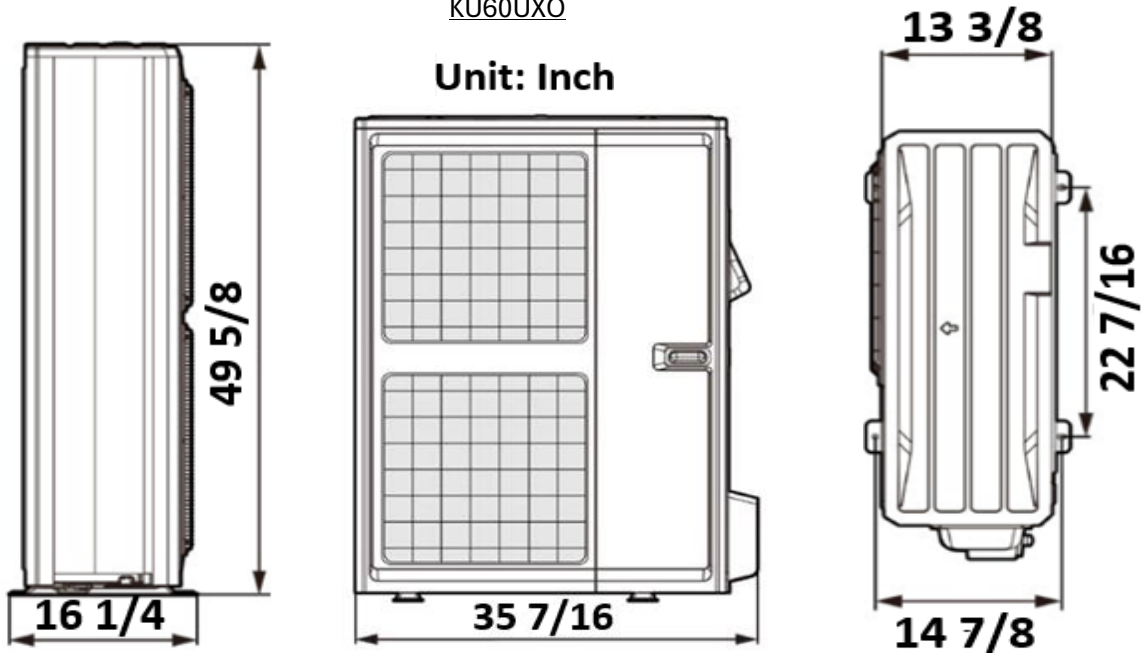

Minimum outdoor unit clearances

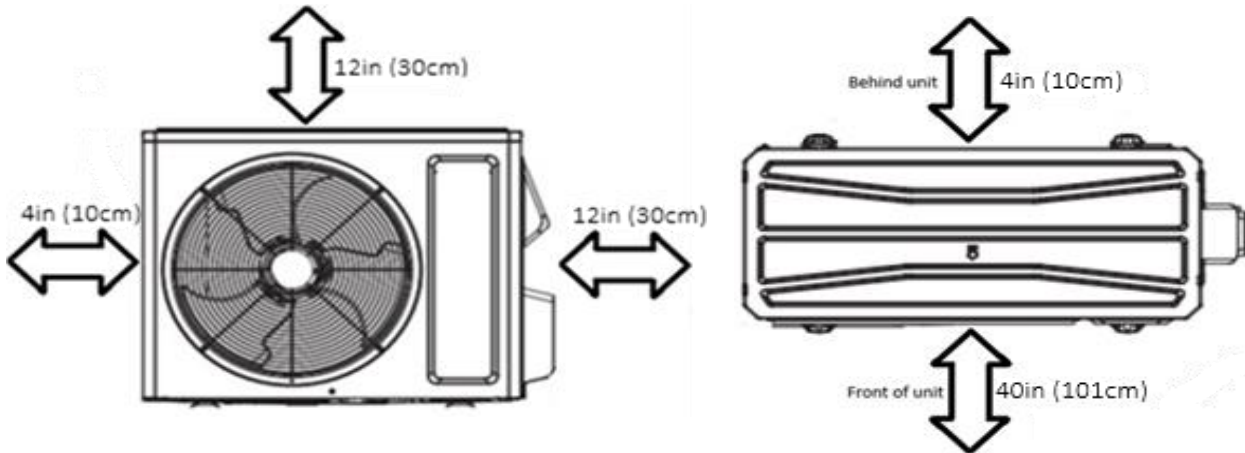

Unit must be placed a minimum 18in (45cm) above any surfaces to allow for snow clearance and defrost runoff.

Please follow local best practices and guidelines.



Indoor unit specifics

KCAC60HI

Move to the left:

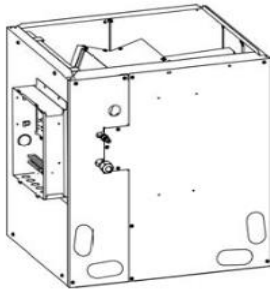

Move to the right:

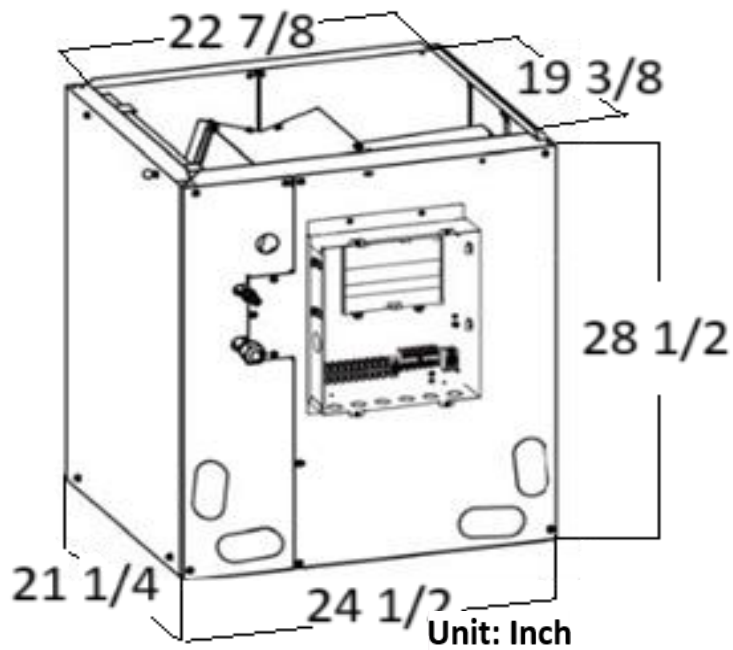
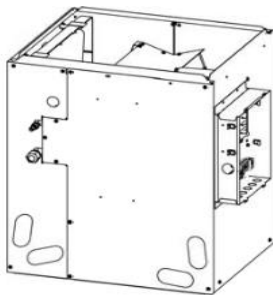

Control board can be moved according to installation needs

Optional Smart thermostat	Technical Specifications	
WK-010WC01 and WK-010WD1	Power Supply	24V/60Hz/1Ph
	Throttling method	Electronic Expansion Valve
	Connection method	Screwed
	Liquid pipe size	3/8in (9.52mm)
	Gas pipe size	3/4in (19mm)
	Net weight	110 lbs (50Kg)
	Gross Weight	123.5 Lbs (56Kg)
	Drain Pipe Outlet	SCH 40 3/4
Includes R32 Refrigerant Sensor		
Can be installed horizontally		