



# ***Owner's Manual***

## **Original Instructions**

Split Air Conditioner

A-Coil

### **Models**

KCA24\*I

KCA36\*I

KCA48\*I

KCA60\*I

Thank you for choosing our product.  
Please read this Owner's Manual carefully before operation and retain it for future reference.

**NOTE:**

**Actual product may be different from graphics,  
please refer to actual products.**

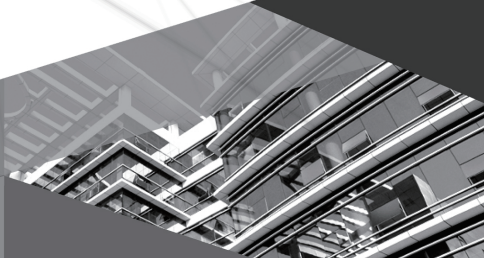

## To Users

Thank you for selecting Gree product. Please read this instruction manual carefully before installing and using the product, so as to master and correctly use the product. In order to guide you to correctly install and use our product and achieve expected operating effect, we hereby instruct as below:

- (1) This appliance can be used by children aged from 8 years and above and persons with reduced physical, sensory or mental capabilities or lack of experience and knowledge if they have been given supervision or instruction concerning use of the appliance in a safe way and understand the hazards involved. Children shall not play with the appliance. Cleaning and user maintenance shall not be made by children without supervision.
- (2) In order to ensure reliability of product, the product may consume some power under stand-by status for maintaining normal communication of system and preheating refrigerant and lubricant. If the product is not to be used for long, cut off the power supply; please energize and preheat the unit in advance before reusing it.
- (3) Please properly select the model according to actual using environment, otherwise it may impact the using convenience.
- (4) This product can't be installed at corrosive, inflammable or explosive environment or the place with special requirements, such as kitchen. Otherwise, it will affect the normal operation or shorten the service life of the unit, or even cause fire hazard or serious injury. As for above special places, please adopt special air conditioner with anti-corrosive or anti-explosion function.
- (5) If the product needs to be installed, moved or maintained, please contact our designated dealer or local service center for professional support. Users should not disassemble or maintain the unit by themselves, otherwise it may cause relative damage, and our company will bear no responsibilities.
- (6) All the illustrations and information in the instruction manual are only for reference. In order to make the product better, we will continuously conduct improvement and innovation. If there is adjustment in the product, please subject to actual product.

# Exception Clauses

Manufacturer will bear no responsibilities when personal injury or property loss is caused by the following reasons:

- (1) Damage the product due to improper use or misuse of the product.
- (2) Alter, change, maintain or use the product with other equipment without abiding by the instruction manual of manufacturer.
- (3) After verification, the defect of product is directly caused by corrosive gas.
- (4) After verification, defects are due to improper operation during transportation of product.
- (5) Operate, repair, maintain the unit without abiding by instruction manual or related regulations.
- (6) After verification, the problem or dispute is caused by the quality specification or performance of parts and components that produced by other manufacturers.
- (7) The damage is caused by natural calamities, bad using environment or force majeure.

# Contents

<b>1 Safety Precautions .....</b>	<b>1</b>
<b>2 Product Introduction .....</b>	<b>2</b>
2.1 Product Description.....	2
2.2 Optional Accessories.....	2
2.3 Physical Dimension.....	3
2.4 Names of Main Parts.....	3
2.5 General Information .....	4
<b>3 General .....</b>	<b>4</b>
<b>4 Installation.....</b>	<b>4</b>
4.1 Pre-Installation Instruction.....	4
4.2 Location .....	5
4.3 Piping Work.....	6
4.4 Condensate Removal.....	7
4.5 Ductwork.....	8
4.6 Unit Installation .....	8
4.7 Sealing Ducts.....	11
4.8 Leak Testing, Vacuuming and Charging .....	11
<b>5 Blower Speed Selection .....</b>	<b>11</b>
<b>6 Maintenance and Care.....</b>	<b>11</b>
6.1 Drain Pipe .....	12
6.2 Notice before Seasonal Use.....	12
6.3 Maintenance after Seasonal Use .....	12
6.4 Parts Replacement.....	12
<b>7 After-Sales Service .....</b>	<b>12</b>

# 1 Safety Precautions

## **WARNING**

This product can't be installed at corrosive, inflammable or explosive environment or the place with special requirements, such as kitchen. Otherwise, it will affect the normal operation or shorten the service life of the unit, or even cause fire hazard or serious injury. As for above special places, please adopt special air conditioner with anti-corrosive or anti-explosion function.

Improper installation, adjustment, alteration, service, maintenance, or use can cause explosion, fire, electrical shock, or other conditions which may cause death, personal injury, or property damage. Consult a qualified installer, service agency, or your distributor or branch for information or assistance. The qualified installer or agency must use factory--authorized kits or accessories when modifying this product. Refer to the individual instructions packaged with the kits or accessories when installing. Follow all safety codes. Wear safety glasses, protective clothing, and work gloves. Use quenching cloth for brazing operations. Have fire extinguisher available. Read these instructions thoroughly and follow all warnings or cautions included in literature and attached to the unit. Consult local building codes and National Electrical Code (NEC) for special requirements. Recognize safety information. This is the safety--alert symbol .

When you see this symbol on the unit and in instructions or manuals, be alert to the potential for personal injury. Understand these signal words: **DANGER**, **WARNING**, **CAUTION** and **NOTICE**. These words are used with the safety--alert symbol.

 **DANGER** Indicates a hazardous situation that, if not avoided, will result in death or serious injury.

 **WARNING** Indicates a hazardous situation that, if not avoided, could result in death or serious injury.

 **CAUTION** Indicates a hazardous situation that, if not avoided, may result in minor or moderate injury.

**NOTICE** Indicates important but not hazard-related information, used to indicate risk of property damage.

## **⚠ WARNING**

### **Electrical shock hazard:**

Failure to follow this warning could result in personal injury or death.

Before installing, modifying, or servicing system, main electrical disconnect switch must be in the OFF position. There may be more than 1 disconnect switch. Lock out and tag switch with a suitable warning label.

## **⚠ WARNING**

Improper installation, adjustment, alteration, service or maintenance can cause personal injury, loss of life, or damage to property.

## **⚠ WARNING**

The temperature of the drain pan can not be above 390°F, if not may cause unit fault, overheat, deform, melt, smoke, even fire hazard.

## **⚠ CAUTION**

As with any mechanical equipment, contact with sharp sheet metal edges can result in personal injury. Take care while handling this equipment and wear gloves and protective clothing.

## 2 Product Introduction

### 2.1 Product Description

The GREE A-Coil offers the perfect combination of superior product quality, operating efficiency, operating sound levels and value for money. The evaporator unit uses the environmentally friendly refrigerant R410A, which is chlorine-free to help prevent damage to the ozone layer.

### 2.2 Optional Accessories

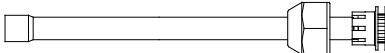
Indoor unit accessories				
No.	Name	Appearance	Q'ty	Usage
1	Throw-over pipe		1	Connect the unit with the liquid pipe
2	Throw-over pipe		1	Connect the unit with the gas pipe

## 2.3 Physical Dimension

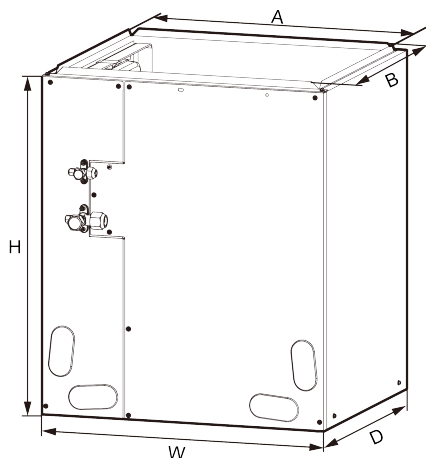

Unit: inch(mm)

Model	Dimension				
	W	D	H	A	B
KCA24*I	17-1/2(445)	21-1/4(540)	23(584)	15-7/8(403)	19-3/8(492)
KCA36*I	17-1/2(445)	21-1/4(540)	23(584)	15-7/8(403)	19-3/8(492)
KCA48*I	24-1/2(622)	21-1/4(540)	28-1/2(724)	22-7/8(581)	19-3/8(492)
KCA60*I	24-1/2(622)	21-1/4(540)	28-1/2(724)	22-7/8(581)	19-3/8(492)

## 2.4 Names of Main Parts

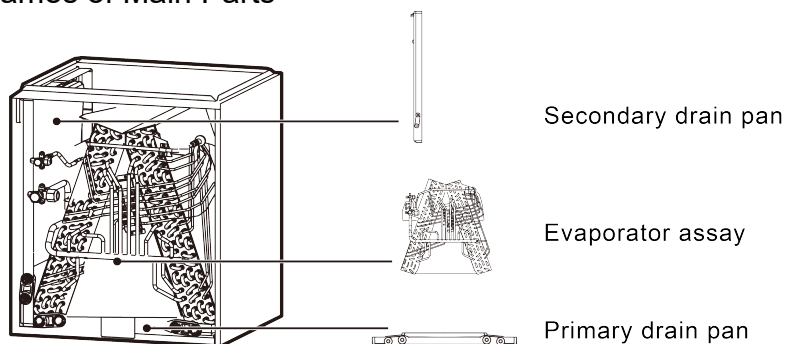

## 2.5 General Information

Cooling capacity range as shown below:

Model	Cooling capacity(ton)
KCA24*I	2.0
KCA36*I	3.0
KCA48*I	4.0
KCA60*I	5.0

## 3 General

The evaporator of indoor unit is charged with refrigerant in factory for pressure maintaining. The cut-off valve can be opened only when installation and vacuuming is done.

Refer to the Product Specification for the proper use of these coils with air handlers, condensers and line sets.

## 4 Installation

### 4.1 Pre-Installation Instruction

#### 4.1.1 Checking Product Received

After receiving the product, please check if there is any damage caused by transportation. Shipping damage is the responsibility of the carrier. Verify the model number, specifications and accessories are correct prior to installation. The distributor or manufacturer will not accept claims from dealers for transportation damage or installation of incorrectly shipped units.

#### 4.1.2 Before Installation

Carefully read all instructions for the installation prior to installing product. Make sure each step or procedure is understood and any special considerations are taken into account before starting installation. Assemble all tools, hardware and supplies needed to complete the installation. Some items may need to be purchased locally. Make sure everything needed to install the product is on hand before starting.

#### 4.1.3 Codes & Regulations

This product is designed and manufactured to comply with national codes. It is installer's responsibilities to install the product in accordance with such codes and/or

any prevailing local codes/regulations. The manufacturer assumes no responsibilities for equipment installed in violation of any codes or regulations.

These instructions are intended as a general guide and do not supersede local or national codes in any way. Authorities who have jurisdiction should be consulted before installation.

#### 4.1.4 Replacement Parts

When reporting shortages or damages, or ordering repair parts, give the complete product model and serial numbers as stamped on the product. Replacement parts for this product are available through your contractor or local distributor.

#### 4.2 Location

**⚠ WARNING** This coil is designed for indoor installation only. Do not install it outdoors.

**⚠ WARNING** Not suitable for use with ammonia.

When installing the coil, take consideration to minimize the length of refrigerant tubing as much as possible. Do not install the air handler in a location either above or below the condenser that violates the instructions provided with the condenser. Service clearance is to take precedence. Allow a minimum of 25" in front of the unit for service clearance, as shown below.

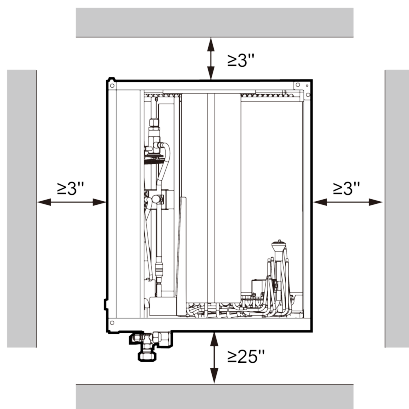

When installing in an area directly over a finished ceiling (such as an attic), an emergency drain pan is required directly under the unit. See local and state codes for requirements. When installing this unit in an area that may become wet, elevate the unit

with a sturdy, non-porous material. In installations that may lead to physical damage (i.e. a garage) it is advised to install a protective barrier to prevent such damage.

It is necessary to allow a minimum of 40" between the inlet/outlet of the indoor unit and wall, as shown below.

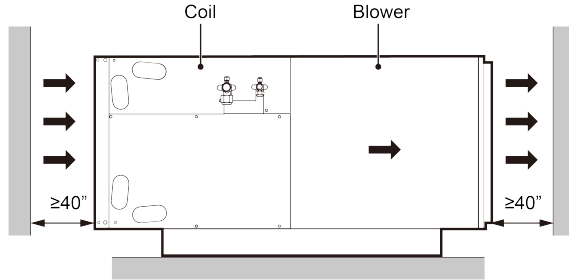

### 4.3 Piping Work

#### 4.3.1 Specification of Connection Pipe

Model	External diameter (inch)	
	Gas pipe	Liquid pipe
KCA24*I	Φ3/4	Φ3/8
KCA36*I		
KCA48*I		
KCA60*I		

#### 4.3.2 Piping Preparation

##### 4.3.2.1 Solder Connection

All cut ends are to be round, burr free, and cleaned. Failure to follow this practice increases the chances for refrigerant leakage.

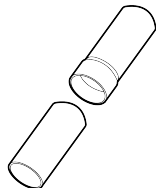

Line set size matches service valve connector

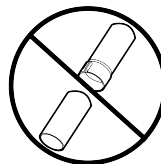

Do not crimp service valve connector when pipe is smaller than connector

### 4.3.2.2 Screw Connection

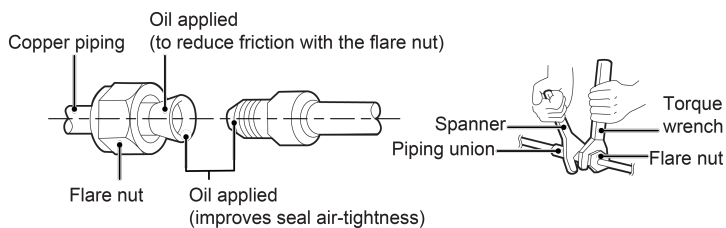

Pipe diameter (inch)	Tightening torque (N·m)
$\Phi 1/4$	15-30
$\Phi 3/8$	35-40
$\Phi 1/2$	45-50
$\Phi 5/8$	60-65
$\Phi 3/4$	70-75
$\Phi 7/8$	80-85

## 4.4 Condensate Removal

- (1) It is not allowed to connect the condensate drain pipe into waste pipe or other pipelines which are likely to produce corrosive or peculiar smell to prevent the smell from entering indoors or corrupt the unit.
- (2) It is not allowed to connect the condensate drain pipe into rain pipe to prevent rain water from pouring in and cause property loss or personal injury.
- (3) Condensate drain pipe should be connected into special drain system for air conditioner.
- (4) The drain pan has primary and secondary drain connection. Condensate removal is performed by attaching a 3/4" PVC pipe to the evaporator coil pan and terminated in accordance with local or state Plumbing/HVAC codes. The installation must include a "P" style trap that is located closely to the evaporator coil. Do not over-tighten the drain connection in order to prevent possible damage to the evaporator drain pan. See the following figure for details of a typical condensate line "P" trap.

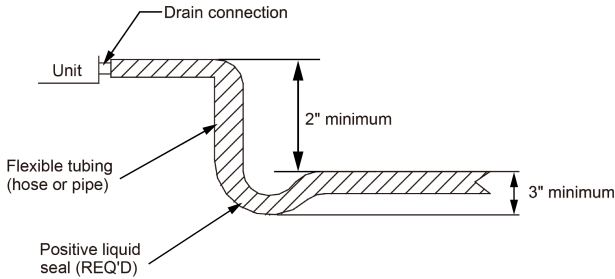

## 4.5 Ductwork

This coil is designed for a complete supply and return ductwork system.

### **⚠ WARNING**

Do not operate the unit without all ductwork completed.

Do not operate this product without all ductwork attached.

Inadequate ductwork that restricts airflow can result in improper performance and compressor or heater failure. Ductwork is to be constructed in a manner that limits restrictions and maintains suitable air velocity. Ductwork is to be sealed to the unit in a manner that will prevent leakage.

Return ductwork: Do not terminate the return ductwork in an area that can introduce toxic or objectionable fumes/odors into the ductwork. The return ductwork is to be introduced into the coil.

Return Air Filters: Each installation must include a return air filter. This filtering may be performed at the coil or externally such as a return air filter grille.

## 4.6 Unit Installation

**⚠ WARNING** Risk of explosion or fire.

**⚠ WARNING** Can cause injury or death.

Install the blower and condensing unit according to the installation instructions provided with the unit.

Position the cased coil on top of the blower cabinet and secure it using field-provided screws.

### **NOTE:**

A stable connection is required between the coil and the blower to prevent dumping.

Based upon the actual conditions, if coil is installed as Fig (A), the coil should be concealed in a specific room or space and make sure the coil is not accessible to the general public.

Based upon the actual conditions, if coil is installed as Fig (B), make sure that there is enough space for care and maintenance. And the coil is not accessible to the general public.

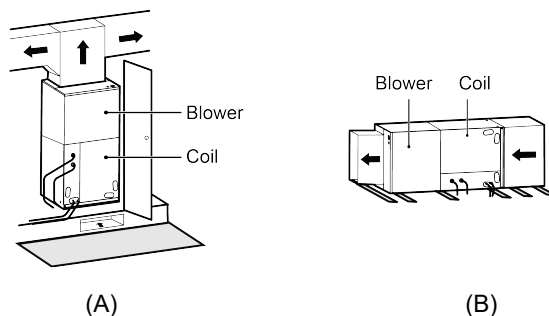

Based upon the actual conditions, Multi-Position A-Coils come factory installed with a vertical and horizontal drain pans and can be configured for upflow or horizontal pull-through installations.

When the coil matches blower, the side which is nearby from coil is NOT allowed to install electric heater kit. Recommended configuring is as shown below.

- (a) Standard Application: Left hand shown / Right hand similar (not shown)
- (b) Counter flow: Right hand shown / Left hand similar (not shown)
- (c) Upward flow
- (d) Downward flow

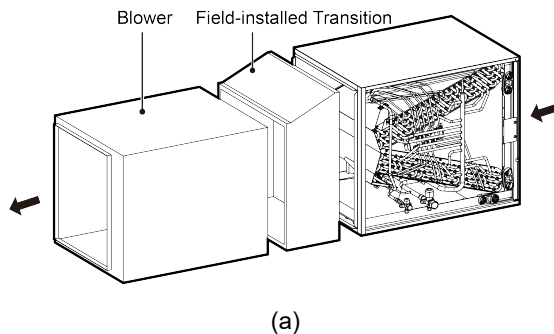

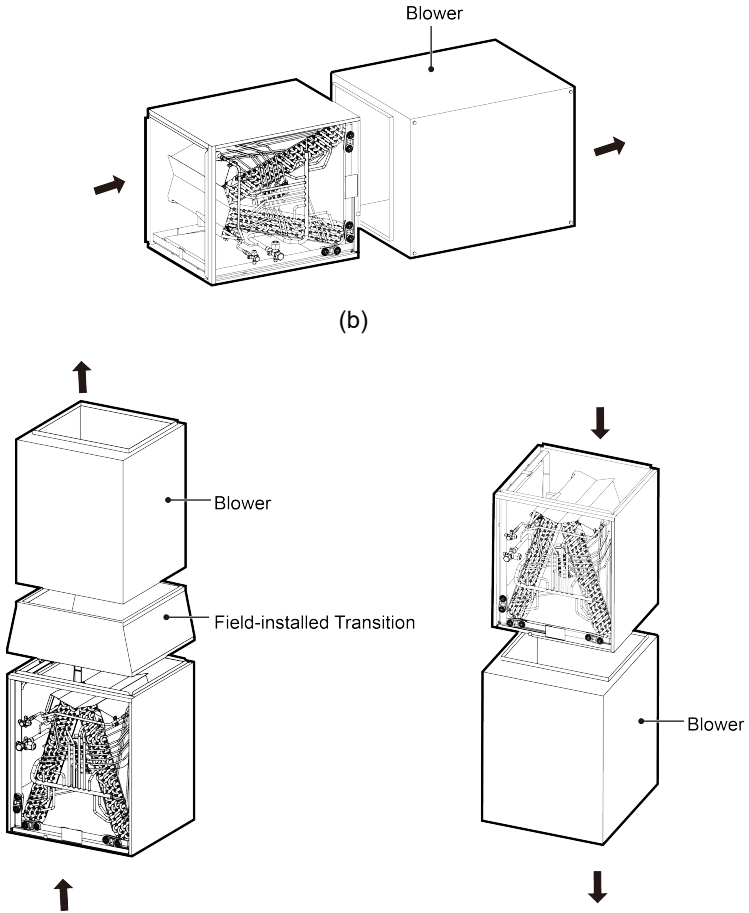

If the air inlet of blower is different with the air outlet of coil in size, it may be necessary to install a field-installed transition between the blower and the coil to proper airflow distribution (as shown in figure (a)).

Coil should be pitched slightly toward the drain connection. It is recommended to add silicone caulk between drain pans to prevent water seepage.

In order to avoid condensate water leakage, it is recommended that the unit install with an external drain pan and check the drain of the unit regularly.

## 4.7 Sealing Ducts

### **⚠ WARNING**

Use fiberglass sealing strips, caulking, or equivalent sealing method between the plenum and the air handler cabinet to ensure a tight seal. Return air must not be drawn from a room where the air handler or any gas-fueled appliance (i.e., water heater), or carbon monoxide-producing device (i.e., wood fireplace) is installed.

Ensure that the duct is secured and all joints are properly sealed to the coil cabinet flanges.

All indoor cabinets **MUST** be taped after installation to seal against any air leaks. System performance and efficiency will be reduced if air leakage exists.

There must be sealed with sponge or other thermal insulation material where around the cut-off valves to prevent air leakage or water seepage.

It is necessary to paste sponge seal around the air outlet to prevent leakage.

## 4.8 Leak Testing, Vacuuming and Charging

Refer to the outdoor unit instruction for leak testing, vacuuming and charging. Always leak check entire system before charging.

When vacuuming, you need to vacuum the liquid and gas pipe at the same time, and do not open the cut-off valve of coil until vacuum finished.

## 5 Blower Speed Selection

Proper air volume must be provided over the evaporator coil. The air volume is selected according to the length of the air duct installed by the project and the static pressure. The air volume of performance test is shown in Table 1.

Table 1

Cabinet		Air Volume(CFM)
Model	Width(in.)	
KCA24*I	17.5	700
KCA36*I	17.5	760
KCA48*I	24.5	1100
KCA60*I	24.5	1100

## 6 Maintenance and Care

Regular check, maintenance and care should be performed by professional

personnel, which will prolong the unit life span.

## 6.1 Drain Pipe

Regularly check if the drain pipe is clogged in order to drain condensate smoothly.

## 6.2 Notice before Seasonal Use

- (1) Check if the inlet/outlet of the indoor unit is clogged.
- (2) Check if the filter screen has been set soundly.
- (3) Check if the unit is installed firmly. If there is something abnormal, please contact the local appointed service center.

## 6.3 Maintenance after Seasonal Use

- (1) Clean the dust of sundries on the indoor units.
- (2) In the event of rusting, use the anti-rust paint to stop spreading of rust.

## 6.4 Parts Replacement

Purchase parts from local appointed service center or dealer if necessary.

# 7 After-Sales Service

In case the air-conditioning unit you bought has any quality problem or you have any inquiry, please contact the local after-sales service agency designated by factory.

### **Warranty should meet the following requirements:**

- (1) First run of the unit should be operated by professional personnel from factory appointed service center.
- (2) Only factory manufactured accessories can be used on the machine.
- (3) All the instructions listed in this manual should be followed.
- (4) Warranty will be automatically invalid if fails to obey any item mentioned above.

