

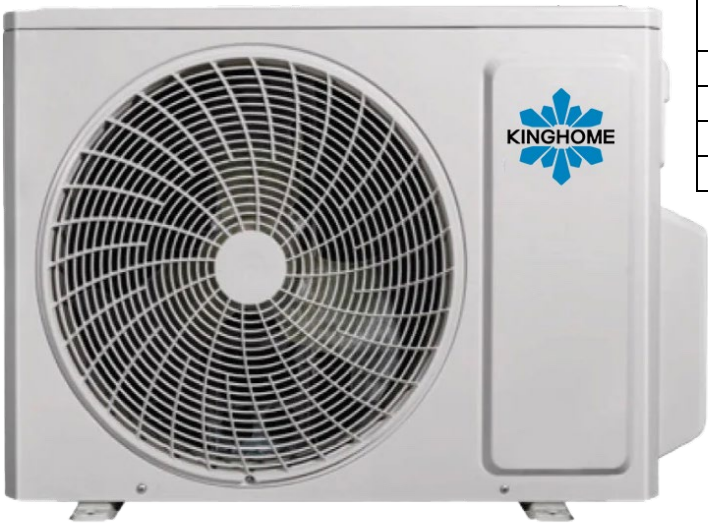

Job name:	Date:
Scheduled Reference:	Contractor:

System information



AHRI number	\	209847248
Outdoor Model	\	KW12HQ25SAO
Indoor Model	\	KW12HQ25SAI
System Rating		
Cooling Capacity (95°F)	Btu/h	12000
Heating Capacity (47°F)	Btu/h	12000
Heating Capacity (17°F)	Btu/h	7000
Cooling Capacity Range	Btu/h	3070-13443
Heating Capacity Range	Btu/h	3070-15012
Power Supply	\	115V/1Ph/60Hz
SEER2	\	24
HSPF2	\	11
EER	W/W	3.5
COP	W/W	3.8
Gas Pipe	inch (mm)	1/2 (12)
Liquid Pipe	inch (mm)	1/4 (6)
Pre-Charge Length	ft (M)	24.6 (7.5)
MIN. Refrigerant Pipe Length	ft (M)	10 (3)
MAX. Refrigerant Pipe Length	ft (M)	82 (25)
MAX. Vertical Height difference between Indoor and Outdoor	ft (M)	66 (20)
Connection Method	\	Screw Connection
Refrigerant Type	\	R410A
Factory Charge	oz	42.3
Additional Charge	oz	0.2

- Features:
- Wi-fi
 - 8C heating mode
 - I-feel function
 - Turbo mode
 - Self-clean function
 - Dehumidify





Outdoor Data and Dimensions

Outdoor Unit Data		
Compressor Type		Rotary
Compressor RLA	A	15
Sound Pressure Level	dB(A)	52
Min/Max Voltage	V	108-126
MCA	A	21
MOP	A	30
Dimension (HxWxD)	inch (mm)	21 54/64 x 31 37/64 x 13 50x64 (555 x 802 x 350)
Net Weight	lb (Kg)	72.7 (33)
Gross Weight	lb (Kg)	78.2 (35.5)
Operating Temperature for Cooling	°F/°C	-20~122 (-29~50)
Operating Temperature for Heating	°F/°C	-22~86 (-30~30)

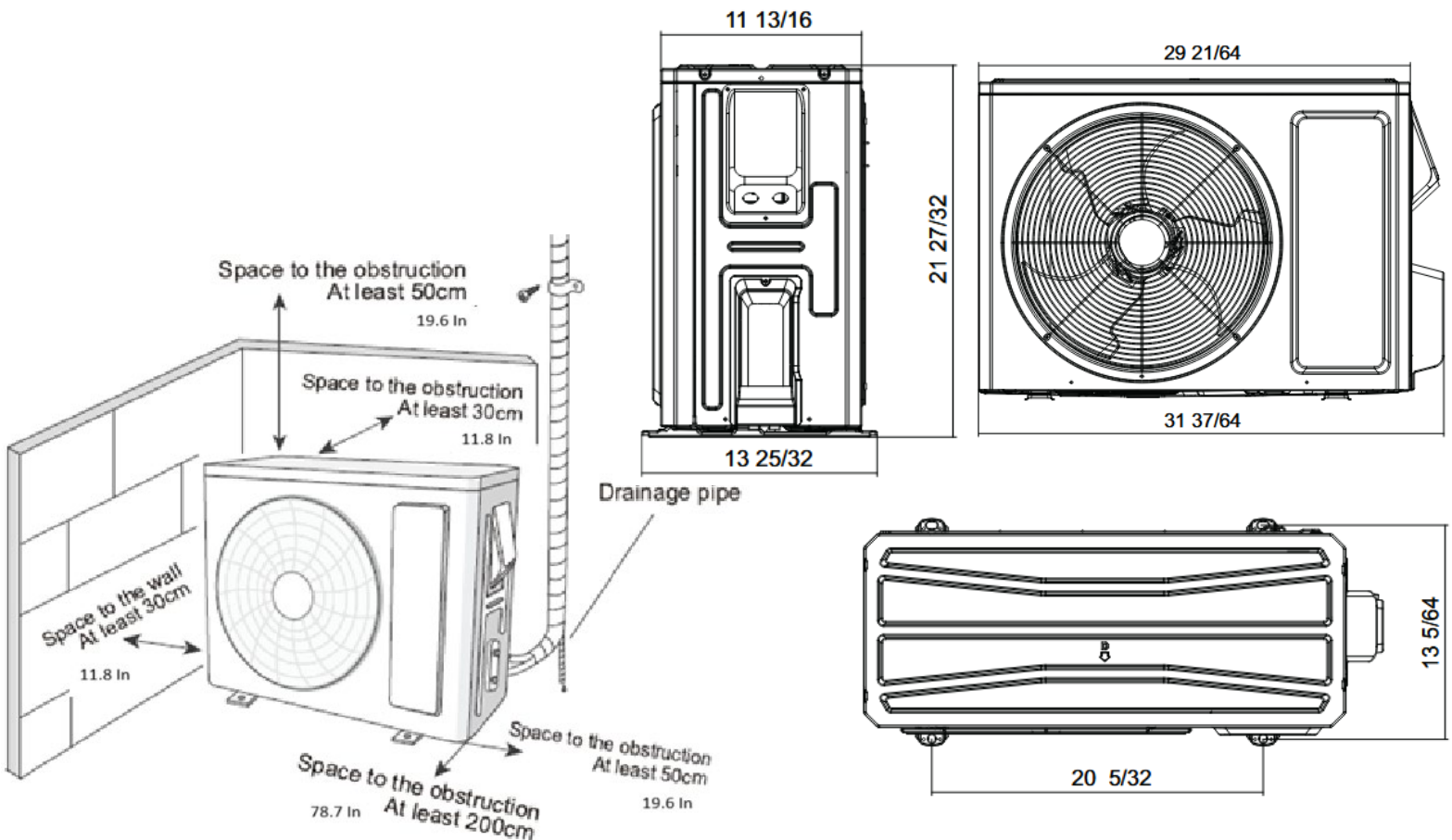

Specifications are subject to change without notice. Manufacturer reserves the right to discontinue or modify specifications or designs without notice or without incurring obligations. All Rights reserved.



Indoor data and Dimensions

Indoor Unit Data		
Air Flow Volume	CFM (m ³ /h)	229~400 (390~680)
Sound Pressure Level	dB(A)	27~43
Dehumidification	pt/hr	2.9
Min/Max Voltage	V	108-126
MCA	A	-
MOP	A	-
Dimension (HxWxD)	inch (mm)	11 24/64 x 33 17/64 x 8 15/64 (289 x 845 x 209)
Net Weight	lb (Kg)	22 (10)
Gross Weight	lb (Kg)	26.5 (12)

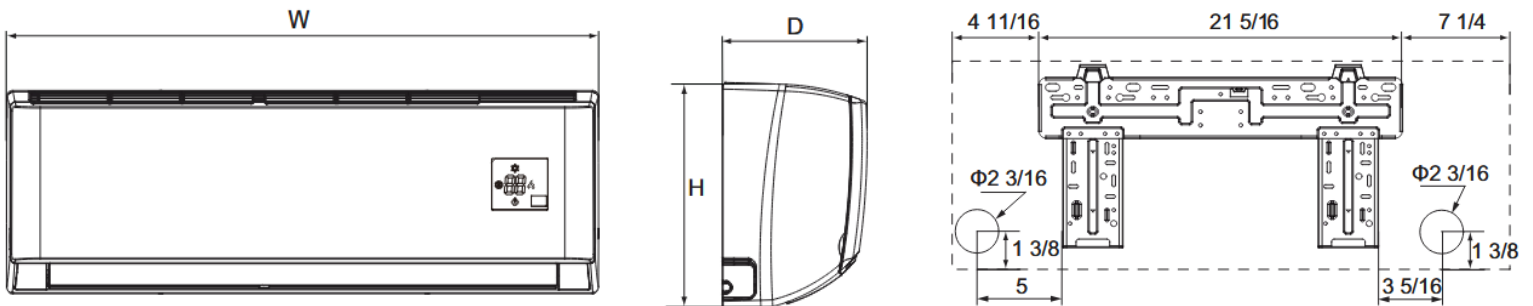

Unit:inch

W	H	D
33 17/64	11 3/8	8 15/64

