



# Submittal-48K-Ultratrix ECO

Job name:		Submitted by:	
Location:		Submitted to:	
Engineer:		Unit tag:	
Date:		Drawing number:	

<b>Warranty information</b>
Standard 7 years parts & compressor
Registered 12 years parts & compressor
Terms and conditions apply

**Type**

Energy Star Heat Pump	<input checked="" type="radio"/>
Cold Climate Energy Star Heat Pump	<input type="radio"/>

**Model numbers**

Indoor:	KD48UXI
Outdoor:	KD60UXO

**Capacity range**

Output (BTU/H)	Minimum	Rated	Max	Certification		
Cooling:	15000	48000	48800	AHRI NO.	Energy Star	nep
Heating:	15800	48000	48800	216626175	3942651	

Heating performance				Efficiency Ratings	
Output (BTU/H)	Minimum	Rated	Max	SEER2	19
47F (8.3C)	15800	48000	48800	HSPF2	9.5
17F (-8.3C)	9800	38500	40400	EER (W/W)	3.4
5F (-15C)	18600	36000	36000	COP (W/W)	3.4

Outdoor temperature range			Electrical	
Cooling:	-15-48C	5-118F	Power supply	208-230V/60Hz/1Ph
Heating:	-15-24C	5-75F	Min/Max voltage	187-253Vac

Condenser specifications			MCA	35A
Connecting type	Screw Connection		MOP	40A
Pre-charge length	25ft (7.5M)		Power Supply Wire	8/3 AWG
MIN. Refrigerant Pipe Length	10 ft (3M)		Interconnecting Wire	18/6AWG or 18/2AWG

Liquid Pipe Size	3/8in (9.52mm)	Features:	
Gas Pipe Size	3/4in (19mm)	Electronic expansion valve	
Max Height Between Indoor/Outdoor	50ft (15M)	Rotary compressor	
Max. Pipe Length	100ft (30M)	Basepan heater	
Refrigerant Type	R-32	Compressor electric heater	

Factory Charge	148.2oz	Weight	
Additional Charge	0.2 oz/ft	Gross weight:	236Lbs (107Kg)
Sound Pressure Level	63dB (A)	Net weight:	214Lbs (97Kg)



Specifications are subject to change without notice. Manufacturer reserves the right to discontinue or modify specifications or designs without notice or without incurring obligations. All Rights reserved.



# Outdoor Unit Dimensions

KD60UXO

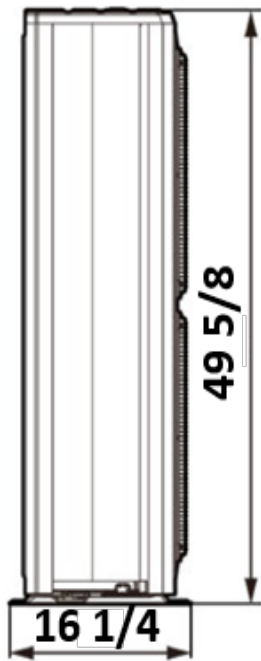

Unit: Inch

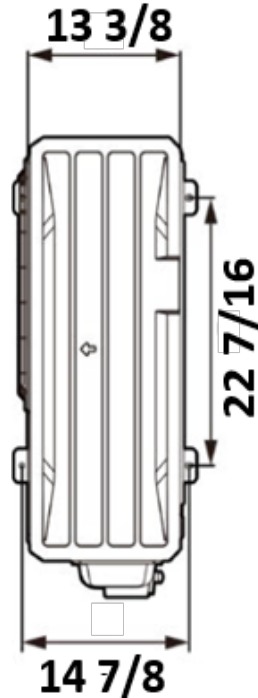
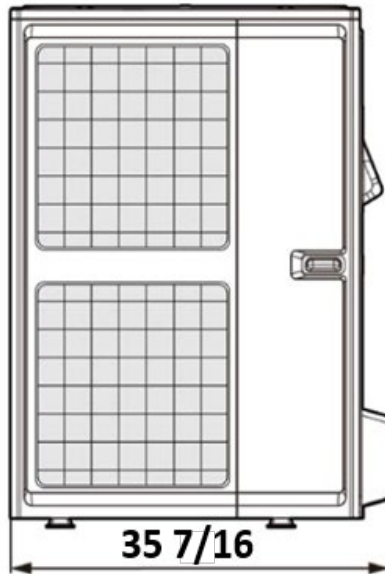

Minimum outdoor unit clearances

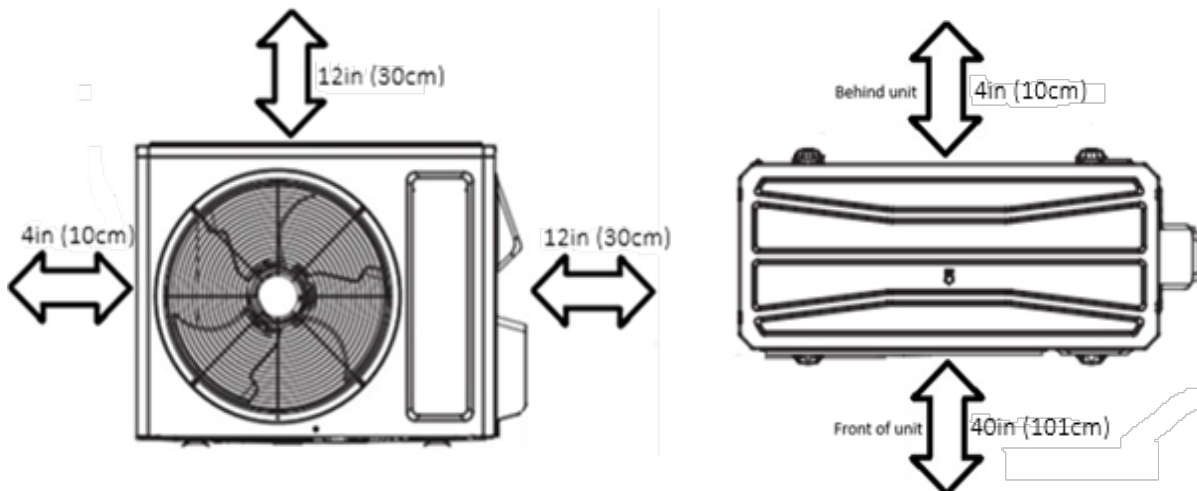

Unit must be placed a minimum 18in (45cm) above any surfaces to allow for snow clearance and defrost runoff.

Please follow local best practices and guidelines.

Specifications are subject to change without notice. Manufacturer reserves the right to discontinue or modify specifications or designs without notice or without incurring obligations. All Rights reserved.



# Indoor unit specifics

KD48UXI

Unit: Inch



Technical Specifications	
Power Supply	208-230V/60Hz/1Ph
Sound pressure level	53dB(A)
MCA	7.1A
MOC	15A
Dehumidification	8.49 pt/hr
Net weight	199.5 lbs (90.5Kg)
Gross Weight	218 Lbs (99Kg)
Drain Pipe Outlet	SCH 40 3/4
*When there is no Electrical Heater installed There is no supplied Electrical breaker	
*If Electrical Heater is installed it will supply power to air handler	

Optional Smart thermostat	Electric Heater kits available					
WK-010WC01 and WK-010WD1	Model number	KW	MCA 240V	MCA 208V	MOC 240V	MOC 208V
* Metal mesh filter included	ECOHTRN10KW	10	52A	45A	60A	45A
20 5/8 x 20 5/16 x 1/2	ECOHTRN15KW	15	52A & 26A	45A & 22.6A	60A & 30A	45A & 25A
Fan Performance	ECOHTRN20KW	20	52A & 52A	45A & 45A	60A & 60A	45A & 45A

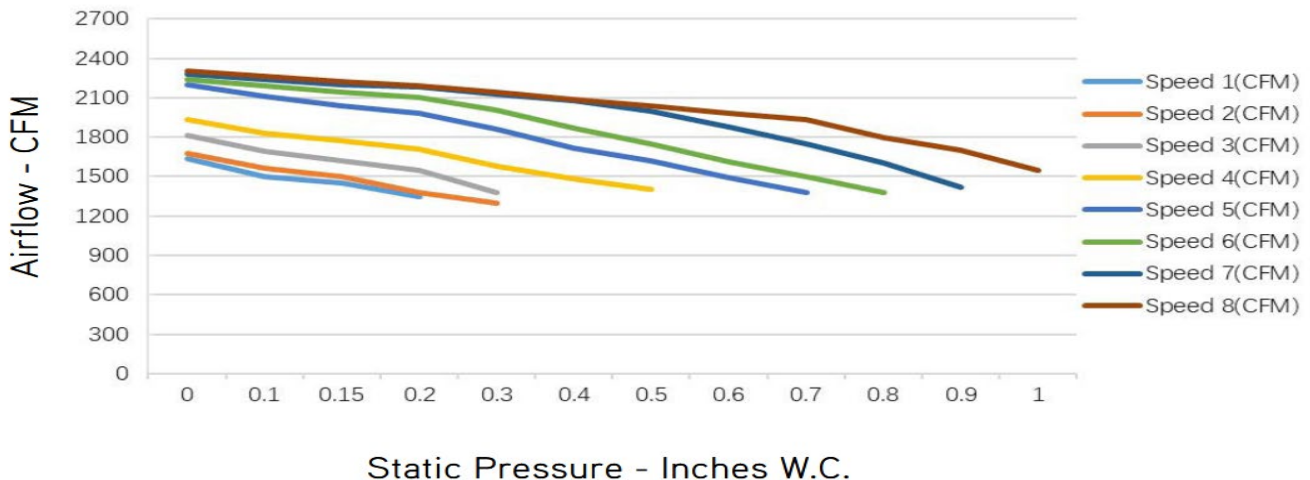

Specifications are subject to change without notice. Manufacturer reserves the right to discontinue or modify specifications or designs without notice or without incurring obligations. All Rights reserved.