



Submittal-60K-Ultratrixx ECO

Job name:		Submitted by:	
Location:		Submitted to:	
Engineer:		Unit tag:	
Date:		Drawing number:	

Warranty information

Standard 7 years parts & compressor
 Registered 12 years parts & compressor
 Terms and conditions apply

Type

Energy Star Heat Pump
 Cold Climate Energy Star Heat Pump

Model numbers

Indoor: KCAC60HI
 Outdoor: KD60UXO

Capacity range

Output (BTU/H)	Minimum	Rated	Max	Certification		
Cooling:	16300	54000	55000	AHRI NO.	Energy Star	nep
Heating:	16000	54000	55000	218046864		

Heating performance

Output (BTU/H)	Minimum	Rated	Max
47F (8.3C)	14400	52000	52500
17F (-8.3C)	7800	33000	33600
5F (-15C)	17900	35000	35000

Efficiency Ratings

SEER2	16
HSPF2	8.5
EER (W/W)	2.9
COP (W/W)	3.4

Outdoor temperature range

Cooling:	-15-48C	5-118F
Heating:	-15-24C	5-75F

Electrical

Power supply	208-230V/60Hz/1Ph
Min/Max voltage	187-253Vac

Condenser specifications

Connecting type	Screw Connection	MCA	35A
Pre-charge length	25ft (7.5M)	MOP	40A
MIN. Refrigerant Pipe Length	10 ft (3M)	Power Supply Wire	8/3 AWG
		Interconnecting Wire	18/6AWG or 18/2AWG

Features:

Electronic expansion valve
Rotary compressor
Basepan heater
Compressor electric heater

Weight

Gross weight:	236Lbs (107Kg)
Net weight:	214Lbs (97Kg)



R32



Specifications are subject to change without notice. Manufacturer reserves the right to discontinue or modify specifications or designs without notice or without incurring obligations. All Rights reserved.



Outdoor Unit Dimensions

KD60UXO

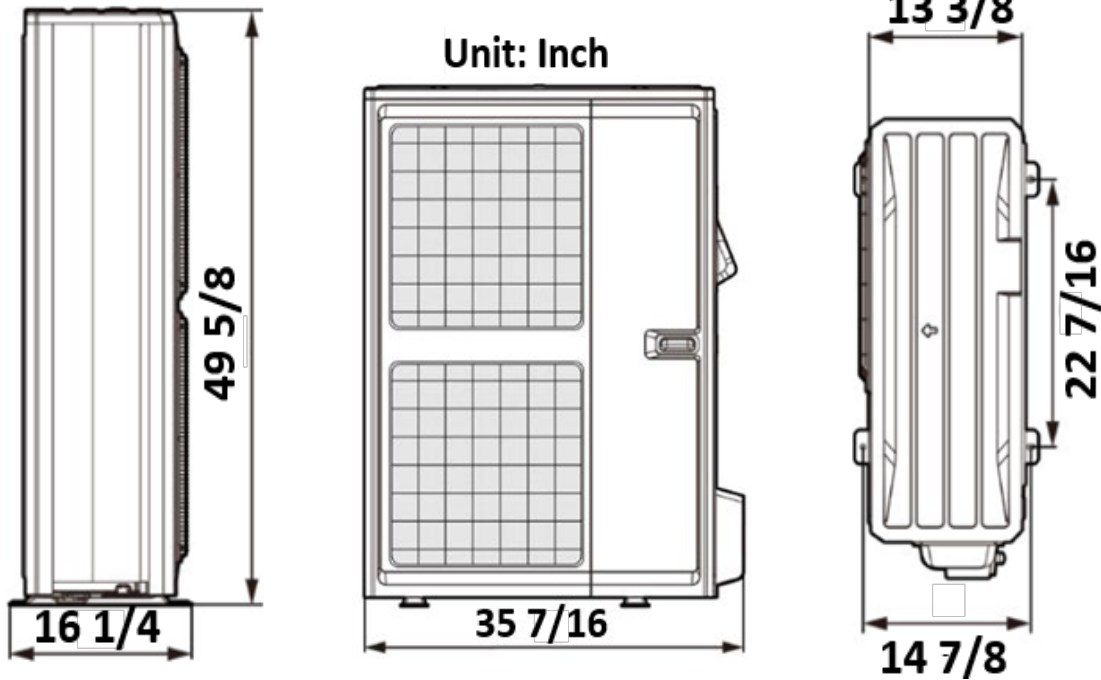

Minimum outdoor unit clearances

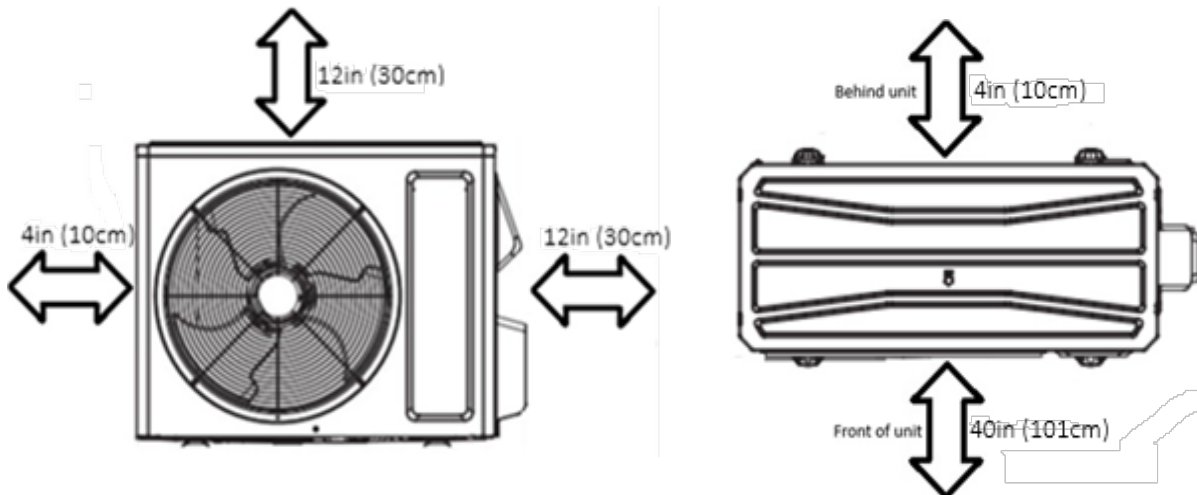

Unit must be placed a minimum 18in (45cm) above any surfaces to allow for snow clearance and defrost runoff.

Please follow local best practices and guidelines.

Specifications are subject to change without notice. Manufacturer reserves the right to discontinue or modify specifications or designs without notice or without incurring obligations. All Rights reserved.



Indoor unit specifics

KCAC60HI

Move to the left:

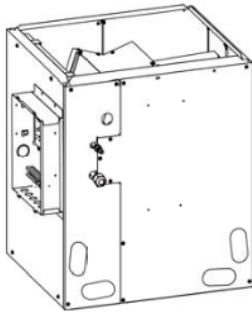

Move to the right:

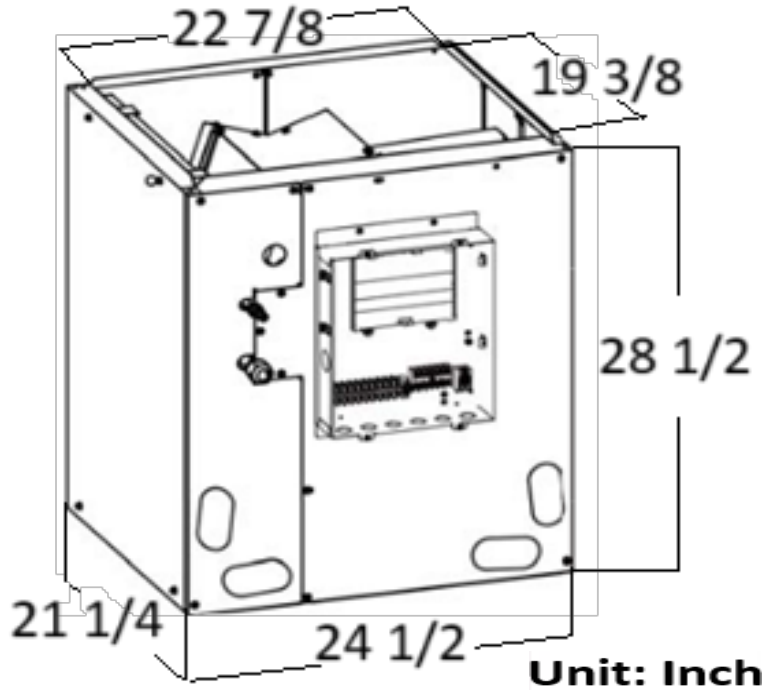
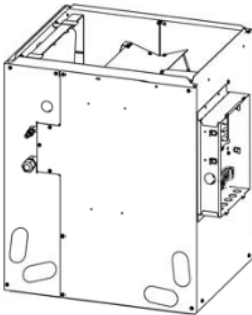

Control board can be moved according to installation needs

Optional Smart thermostat	Technical Specifications	
WK-010WC01 and WK-010WD1	Power Supply	24V/60Hz/1Ph
	Throttling method	Electronic Expansion Valve
	Connection method	Screwed
	Liquid pipe size	3/8in (9.52mm)
	Gas pipe size	3/4in (19mm)
	Net weight	110 lbs (50Kg)
	Gross Weight	123.5 Lbs (56Kg)
	Drain Pipe Outlet	SCH 40 3/4
	Includes R32 Refrigerant Sensor	
Can be installed horizontally		

Specifications are subject to change without notice. Manufacturer reserves the right to discontinue or modify specifications or designs without notice or without incurring obligations. All Rights reserved.