



Submittal-36K-Ultratrixx ECO

Job name:		Submitted by:	
Location:		Submitted to:	
Engineer:		Unit tag:	
Date:		Drawing number:	

Warranty information
 Standard 7 years parts & compressor
 Registered 12 years parts & compressor
 Terms and conditions apply

Type
 Energy Star Heat Pump
 Cold Climate Energy Star Heat Pump

Model numbers
 Indoor: KCAC36FI
 Outdoor: KD36UXO

Capacity range



Output (BTU/H)	Minimum	Rated	Max	Certification		
Cooling:	12000	34000	34500	AHRI NO.	Energy Star	nep
Heating:	11600	34000	34500	218046862		

Heating performance				Efficiency Ratings	
Output (BTU/H)	Minimum	Rated	Max	SEER2	
47F (8.3C)	12200	33000	33400	HSPF2	16
17F (-8.3C)	6800	20000	22000	EER (W/W)	8.5
5F (-15C)	15000	19000	19000	COP (W/W)	3.2
					3.5

Outdoor temperature range			Electrical	
Cooling:	-15-48C	5-118F	Power supply	208-230V/60Hz/1Ph
Heating:	-15-24C	5-75F	Min/Max voltage	187-253Vac

Condenser specifications		MCA	21A
Connecting type	Screw Connection	MOP	25A
Pre-charge length	25ft (7.5M)	Power Supply Wire	10/3 AWG
MIN. Refrigerant Pipe Length	10 ft (3M)	Interconnecting Wire	18/6AWG or 18/2AWG

		Features:	
Liquid Pipe Size	3/8in (9.52mm)	Electronic expansion valve	
Gas Pipe Size	3/4in (19mm)	Rotary compressor	
Max Height Between Indoor/Outdoor	50ft (15M)	Basepan heater	
Max. Pipe Length	100ft (30M)	Compressor electric heater	
Refrigerant Type	R-32		

		Weight	
Factory Charge	98.8oz	Gross weight:	133.4Lbs (60.5Kg)
Additional Charge	0.2 oz/ft	Net weight:	125Lbs (56.5Kg)
Sound Pressure Level	60dB (A)		

Specifications are subject to change without notice. Manufacturer reserves the right to discontinue or modify specifications or designs without notice or without incurring obligations. All Rights reserved.



Outdoor Unit Dimensions

KD36UXO

Unit: Inch

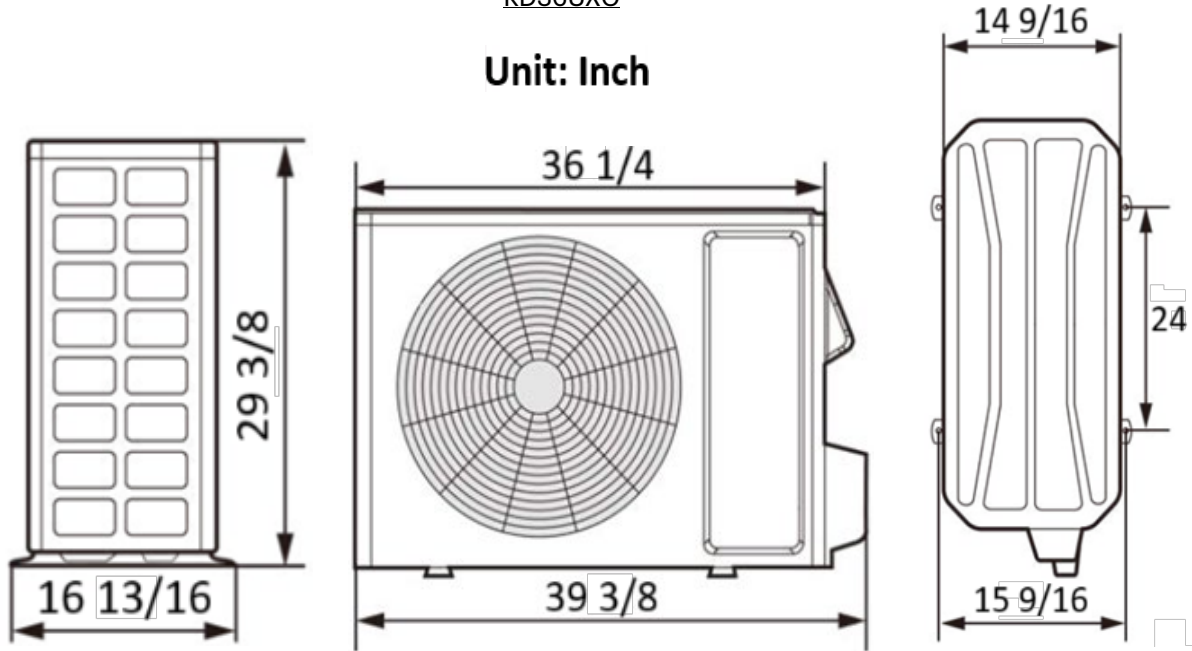

Minimum outdoor unit clearances

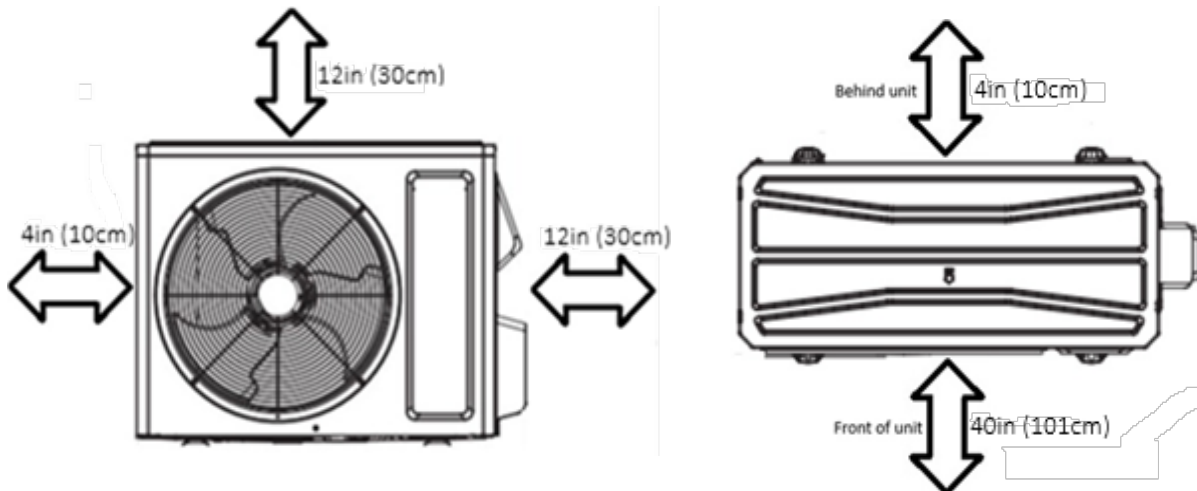

Unit must be placed a minimum 18in (45cm) above any surfaces to allow for snow clearance and defrost runoff.

Please follow local best practices and guidelines.

Specifications are subject to change without notice. Manufacturer reserves the right to discontinue or modify specifications or designs without notice or without incurring obligations. All Rights reserved.



Indoor unit specifics

KCAC36FI

Move to the left:

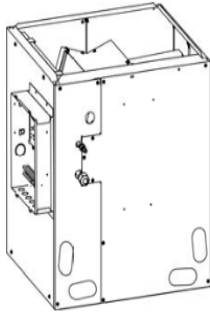

Move to the right:

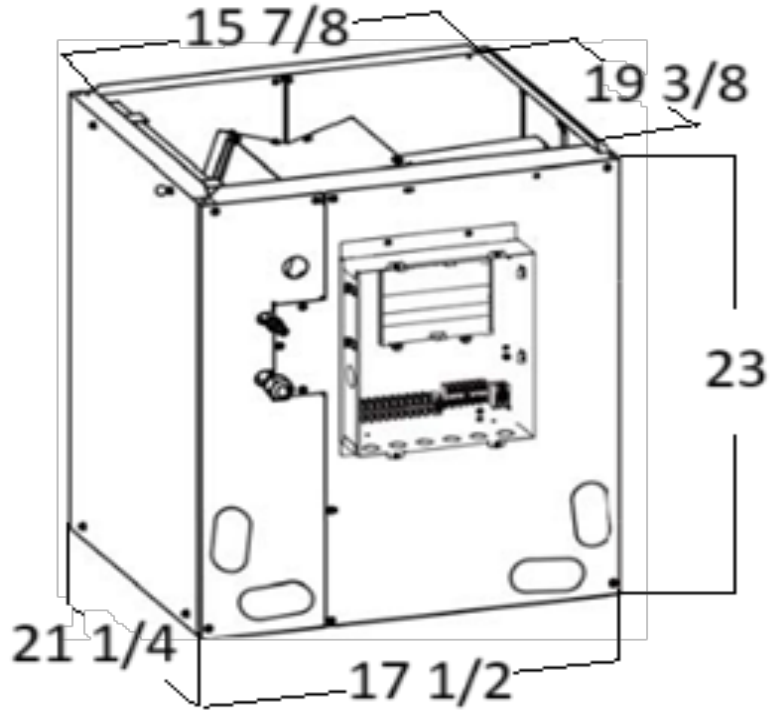
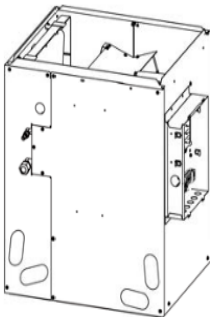

Control board can be moved according to installation needs

Unit: Inch

Optional Smart thermostat	Technical Specifications	
WK-010WC01 and WK-010WD1	Power Supply	24V/60Hz/1Ph
	Throttling method	Electronic Expansion Valve
	Connection method	Screwed
	Liquid pipe size	3/8in (9.52mm)
	Gas pipe size	3/4in (19mm)
	Net weight	75 lbs (34Kg)
	Gross Weight	83.8 Lbs (38Kg)
	Drain Pipe Outlet	SCH 40 3/4
	Includes R32 Refrigerant Sensor	
Can be installed horizontally		

Specifications are subject to change without notice. Manufacturer reserves the right to discontinue or modify specifications or designs without notice or without incurring obligations. All Rights reserved.