



# Submittal-30K-Ultratrixx ECO

Job name:		Submitted by:	
Location:		Submitted to:	
Engineer:		Unit tag:	
Date:		Drawing number:	

<b>Warranty information</b>
Standard 7 years parts & compressor
Registered 12 years parts & compressor
Terms and conditions apply

**Type**

Energy Star Heat Pump	<input type="radio"/>
Cold Climate Energy Star Heat Pump	<input type="radio"/>

**Model numbers**

Indoor:	KCAC36FI
Outdoor:	KD30UXO

**Capacity range**

Output (BTU/H)	Minimum	Rated	Max	Certification		
Cooling:	11800	28000	28400	AHRI NO.	Energy Star	nep
Heating:	11000	28000	28200			

Heating performance				Efficiency Ratings	
Output (BTU/H)	Minimum	Rated	Max	SEER2	18
47F (8.3C)	11000	28000	28200	HSPF2	8.3
17F (-8.3C)	8300	23000	28000	EER (W/W)	3.4
5F (-15C)	15200	19500	19500	COP (W/W)	3.5

Outdoor temperature range			Electrical	
Cooling:	-15-48C	5-118F	Power supply	208-230V/60Hz/1Ph
Heating:	-15-24C	5-75F	Min/Max voltage	187-253Vac

Condenser specifications			MCA	21A
Connecting type	Screw Connection		MOP	25A
Pre-charge length	25ft (7.5M)		Power Supply Wire	10/3 AWG
MIN. Refrigerant Pipe Length	10 ft (3M)		Interconnecting Wire	18/6AWG or 18/2AWG

Liquid Pipe Size	3/8in (9.52mm)	Features:	
Gas Pipe Size	3/4in (19mm)	Electronic expansion valve	
Max Height Between Indoor/Outdoor	50ft (15M)	Rotary compressor	
Max. Pipe Length	100ft (30M)	Basepan heater	
Refrigerant Type	R-32	Compressor electric heater	

Factory Charge	67oz	Weight	
Additional Charge	0.2 oz/ft	Gross weight:	122.4Lbs (55.5Kg)
Sound Pressure Level	58dB (A)	Net weight:	113.5Lbs (51.5Kg)



Specifications are subject to change without notice. Manufacturer reserves the right to discontinue or modify specifications or designs without notice or without incurring obligations. All Rights reserved.



# Outdoor Unit Dimensions

KD30UXO

Unit: Inch

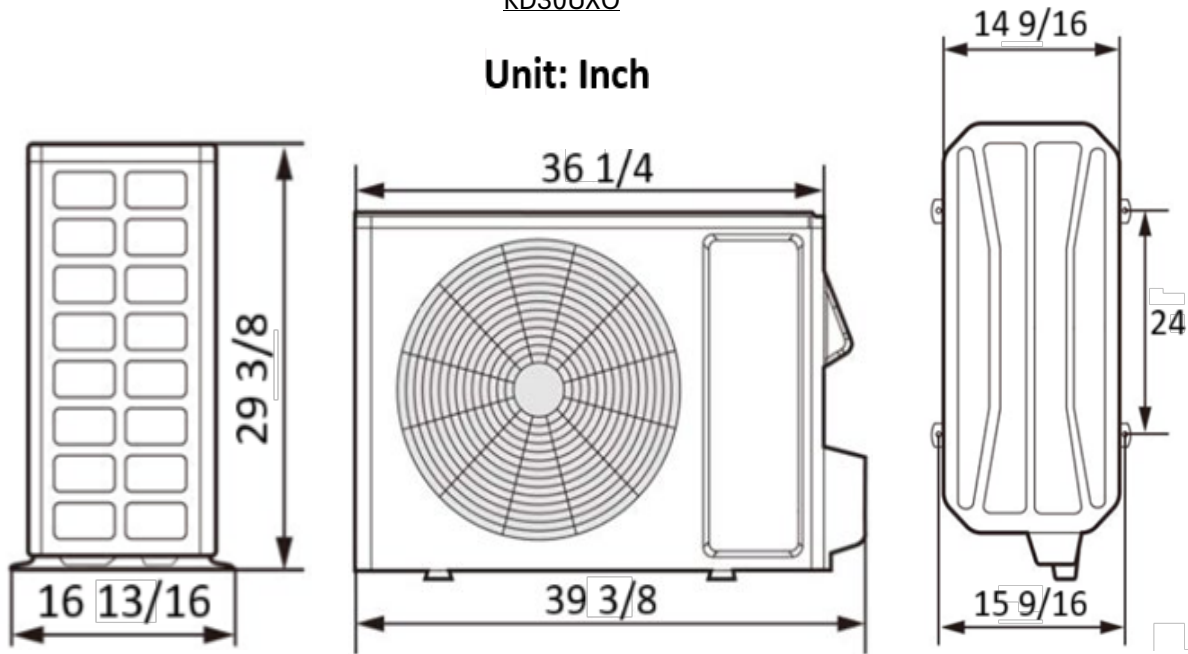

## Minimum outdoor unit clearances

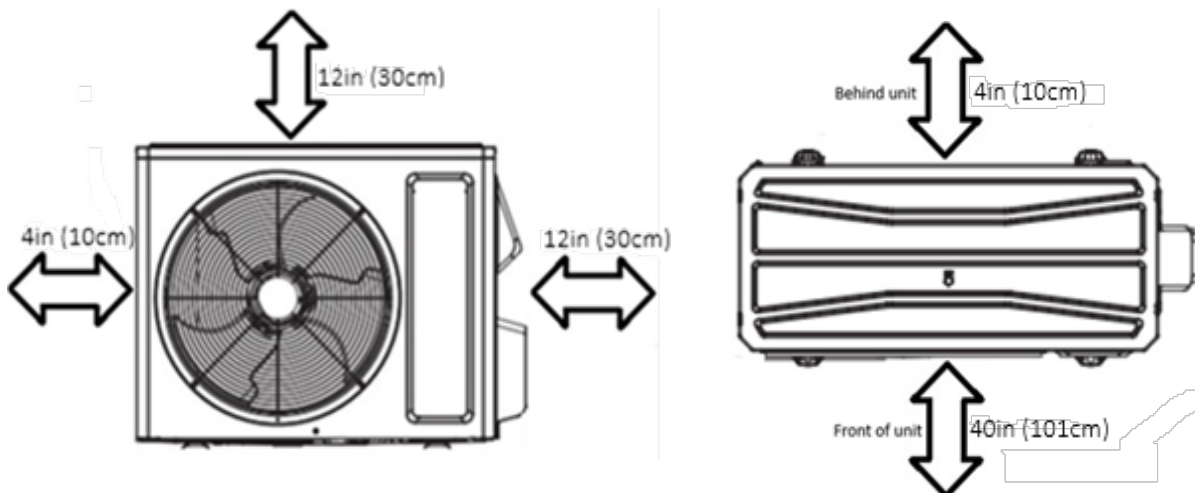

Unit must be placed a minimum 18in (45cm) above any surfaces to allow for snow clearance and defrost runoff.

Please follow local best practices and guidelines.

Specifications are subject to change without notice. Manufacturer reserves the right to discontinue or modify specifications or designs without notice or without incurring obligations. All Rights reserved.



# Indoor unit specifics

KCAC36FI

Move to the left:

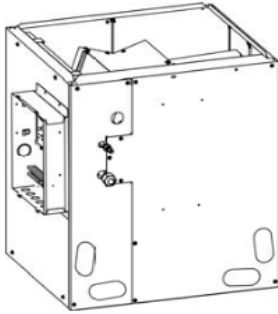

Move to the right:

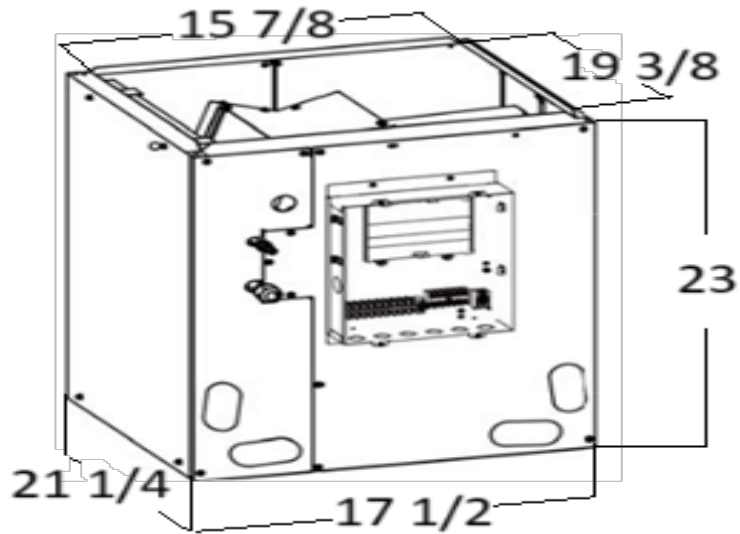
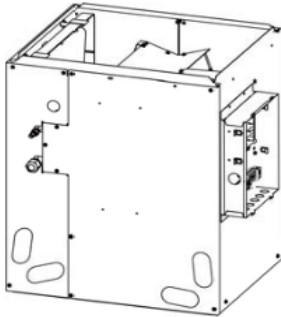

**Unit: Inch**

Control board can be moved according to installation needs

Optional Smart thermostat	Technical Specifications	
WK-010WC01 and WK-010WD1	Power Supply	24V/60Hz/1Ph
	Throttling method	Electronic Expansion Valve
	Connection method	Screwed
	Liquid pipe size	3/8in (9.52mm)
	Gas pipe size	3/4in (19mm)
	Net weight	75 lbs (34Kg)
	Gross Weight	83.8 Lbs (38Kg)
	Drain Pipe Outlet	SCH 40 3/4
Includes R32 Refrigerant Sensor		
Can be installed horizontally		

Specifications are subject to change without notice. Manufacturer reserves the right to discontinue or modify specifications or designs without notice or without incurring obligations. All Rights reserved.