



SPLIT TYPE

CLIVIA

Model:
KW24XQ25SDI
KW24XQ25SDO



- Auto-Clean function
- Dehumidification
- I-Feel function
- Self-diagnosis
- Multiple fan speeds
- Low Voltage start-up
- Swing louver control
- Intelligent Defrosting

Item	Unit	Parameter
AHRI number	\	216020675
Outdoor Model	\	KW24XQ25PDO
Indoor Model	\	KW24XQ25PDI
System Rating		
Cooling Capacity (95°F)	Btu/h	22000
Heating Capacity (47°F)	Btu/h	24000
Heating Capacity (17°F)	Btu/h	20000
Cooling Capacity Range	Btu/h	3340-28660
Heating Capacity Range	Btu/h	4300-33600
Power Supply	\	208~230V/1Ph/60Hz
SEER2	\	26
HSPF2	\	10
EER2	\	13.65
COP	\	3.8
Gas Pipe	inch (mm)	5/8 (16)
Liquid Pipe	inch (mm)	1/4 (6)
Standard Pipe Length	ft (M)	24.6 (7.5)
MIN. Refrigerant Pipe Length	ft (M)	10 (3)
MAX. Refrigerant Pipe Length	ft (M)	131.2 (40)
MAX. Vertical Height difference between Indoor and Outdoor	ft (M)	82 (25)
Connection Method	\	Screw Connection
Refrigerant Type	\	R32
Factory Charge	oz	42.3
Additional Charge	oz/ft	0.4
Pre-Charge Length	ft (M)	24.6 (7.5)
Controller Model	\	YBE1FB1F

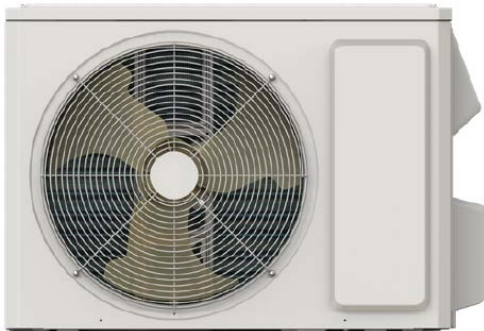

Job Name:

Schedule Reference:

Date:



SPLIT TYPE

CLIVIA

**Model:
KW24XQ25SDI
KW24XQ25SDO**



Indoor Unit Data		
Air Flow Volume	CFM (m ³ /h)	235~559 (400~950)
Sound Pressure Level	dB(A)	29~47
Dehumidification	pt/hr	5.07
Min/Max Voltage	V	187~253
MCA	A	-
MOP	A	-
Dimension (HxWxD)	inch (mm)	12 1/4 x 39 3/32 x 8 47/64 (311 x 993 x 222)
Net Weight	lb (Kg)	29.8 (13.5)
Gross Weight	lb (Kg)	35.3 (16)
Outdoor Unit Data		
Compressor Type	\	Rotary
Compressor Oil	\	FW68L
Compressor RLA	A	15.3
Sound Pressure Level	dB(A)	58
Min/Max Voltage	V	187~253
MCA	A	22
MOP	A	30
Dimension (HxWxD)	inch (mm)	25 63/64 x 37 23/32 x 15 53/64 (660 x 958 x 402)
Net Weight	lb (Kg)	92.6 (42)
Gross Weight	lb (Kg)	102.5 (46.5)
Operating Temperature for Cooling	°F/°C	-20~122 (-29~50)
Operating Temperature for Heating	°F/°C	-22~86 (-30~30)

Job Name:

Schedule Reference:

Date:

Specification are subject to change without notice.



Outline and Physical Dimensions

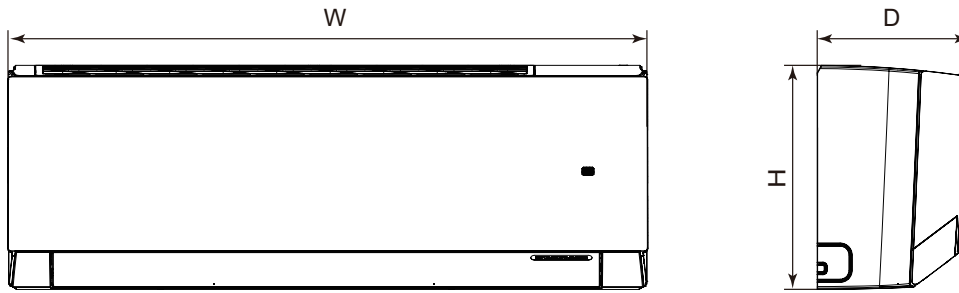

Dimensions Inch (mm)	9K-12K	18K	24K
H	11 17/32 (293)	12 1/4 (311)	12 1/4 (311)
W	32 61/64 (837)	39 3/32 (993)	39 3/32 (993)
D	7 56/64 (200)	8 47/64 (222)	8 47/64 (222)

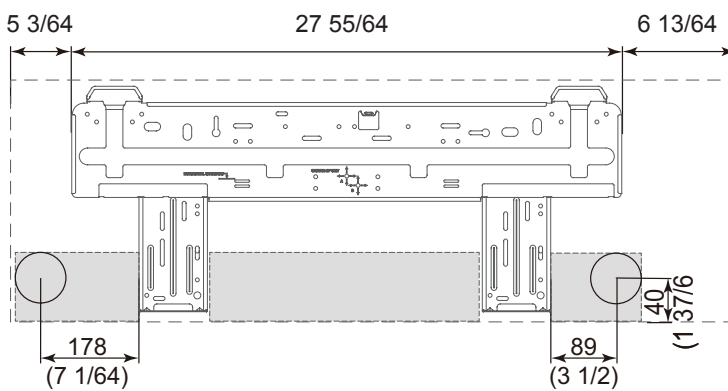

Liquid Line Valve	1/4-in OD Flared
Gas Line Valve	5/8-in OD Flared
Drain Connector	5/8-in OD





Outline and Physical Dimensions

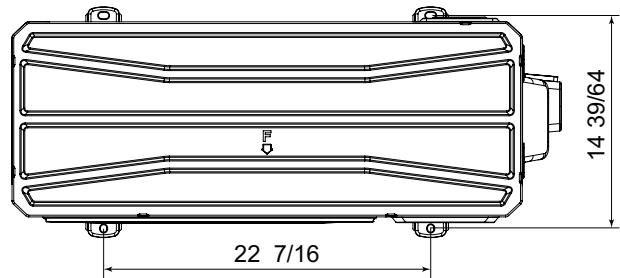
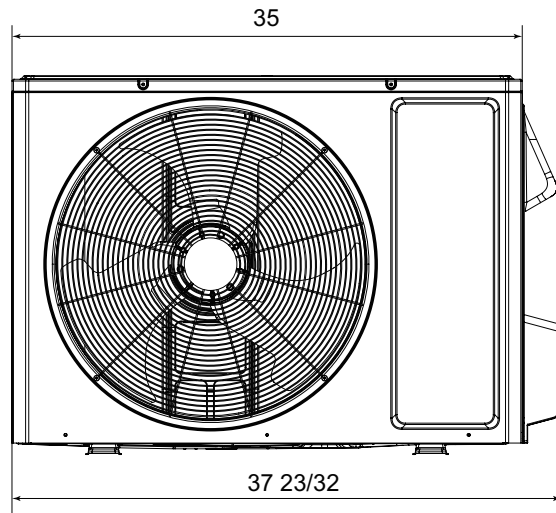
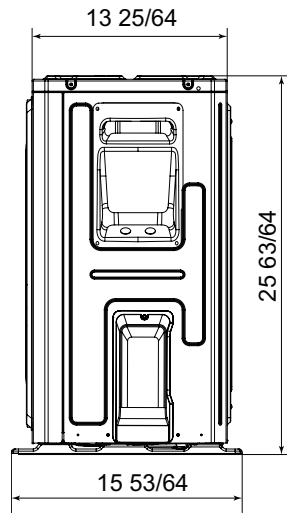

Liquid Line Valve	1/4-in OD Flared
Gas Line Valve	5/8-in OD Flared

Dimensions Inch (mm)	9K-12K	18K	24K
H	21 27/32 (555)	25 63/64 (660)	25 63/64 (660)
W	31 37/64 (802)	37 23/32 (958)	37 23/32 (958)
D	13 50/64 (350)	15 53/64 (402)	15 53/64 (402)

