



SPLIT TYPE

CLIVIA

Model:
KW12XQ25SDI
KW12XQ25SDO



- Auto-Clean function
- Dehumidification
- I-Feel function
- Self-diagnosis
- Multiple fan speeds
- Low Voltage start-up
- Swing louver control
- Intelligent Defrosting
- Optional ERV

Item	Unit	Parameter
AHRI number	\	216372816
Outdoor Model	\	KW12XQ25SDO
Indoor Model	\	KW12XQ25SDI
System Rating		
Cooling Capacity (95°F)	Btu/h	12000
Heating Capacity (47°F)	Btu/h	12000
Heating Capacity (17°F)	Btu/h	10000
Cooling Capacity Range	Btu/h	2700-15000
Heating Capacity Range	Btu/h	3070-15690
Power Supply	\	208~230V/1Ph/60Hz
SEER2	\	24.5
HSPF2	\	9.5
EER2	\	13
COP	\	3.82
Gas Pipe	inch (mm)	1/2 (12)
Liquid Pipe	inch (mm)	1/4 (6)
Standard Pipe Length	ft (M)	24.6 (7.5)
MIN. Refrigerant Pipe Length	ft (M)	10 (3)
MAX. Refrigerant Pipe Length	ft (M)	65.6 (20)
MAX. Vertical Height difference between Indoor and Outdoor	ft (M)	40 (12)
Connection Method	\	Screw Connection
Refrigerant Type	\	R32
Factory Charge	oz	28.2
Additional Charge	oz/ft	0.2
Pre-Charge Length	ft (M)	24.6 (7.5)
Controller Model	\	YBE1FB1F

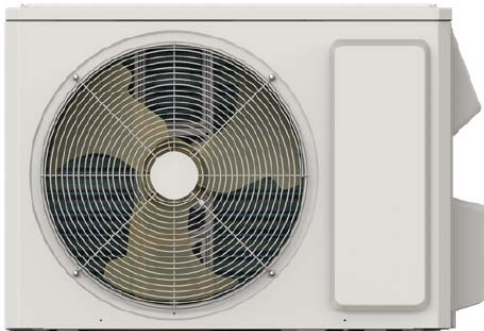

Job Name:

Schedule Reference:

Date:



SPLIT TYPE

CLIVIA

**Model:
KW12XQ25SDI
KW12XQ25SDO**



Indoor Unit Data		
Air Flow Volume	CFM (m ³ /h)	212~400 (360~680)
Sound Pressure Level	dB(A)	20~43
Dehumidification	pt/hr	2.96
Min/Max Voltage	V	187~253
MCA	A	-
MOP	A	-
Dimension (HxWxD)	inch (mm)	11 34/64 x 32 61/64 x 7 56/64 (293 x 837 x 200)
Net Weight	lb (Kg)	20.9 (9.5)
Gross Weight	lb (Kg)	25.4 (11.5)
Outdoor Unit Data		
Compressor Type	\	Rotary
Compressor Oil	\	FW68L
Compressor RLA	A	7
Sound Pressure Level	dB(A)	52
Min/Max Voltage	V	187~253
MCA	A	10
MOP	A	15
Dimension (HxWxD)	inch (mm)	21 54/64 x 31 37/64 x 13 50/64 (555 x 802 x 350)
Net Weight	lb (Kg)	67.3 (30.5)
Gross Weight	lb (Kg)	72.8 (33)
Operating Temperature for Cooling	°F/°C	-20~122 (-29~50)
Operating Temperature for Heating	°F/°C	-22~86 (-30~30)

Job Name:

Schedule Reference:

Date:

Specification are subject to change without notice.



Outline and Physical Dimensions

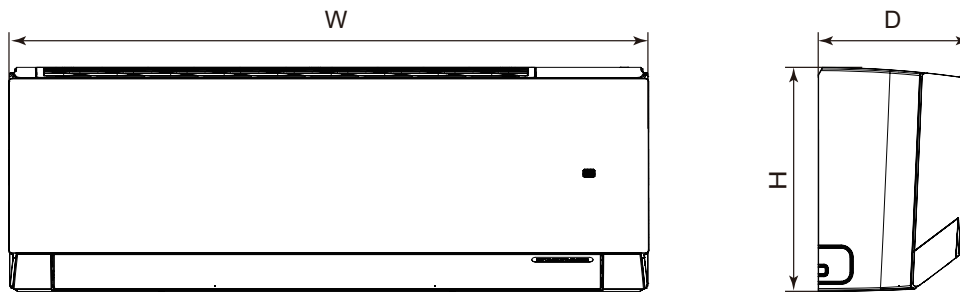

Dimensions Inch (mm)	9K-12K	18K	24K
H	11 17/32 (293)	12 1/4 (311)	12 1/4 (311)
W	32 61/64 (837)	39 3/32 (993)	39 3/32 (993)
D	7 56/64 (200)	8 47/64 (222)	8 47/64 (222)

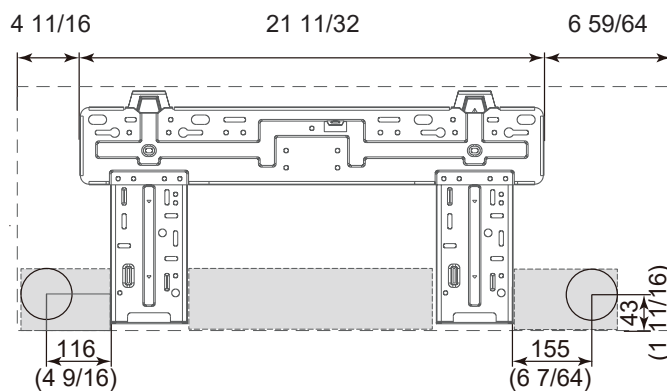

Liquid Line Valve	1/4-in OD Flared
Gas Line Valve	1/2-in OD Flared
Drain Connector	5/8-in OD





Outline and Physical Dimensions

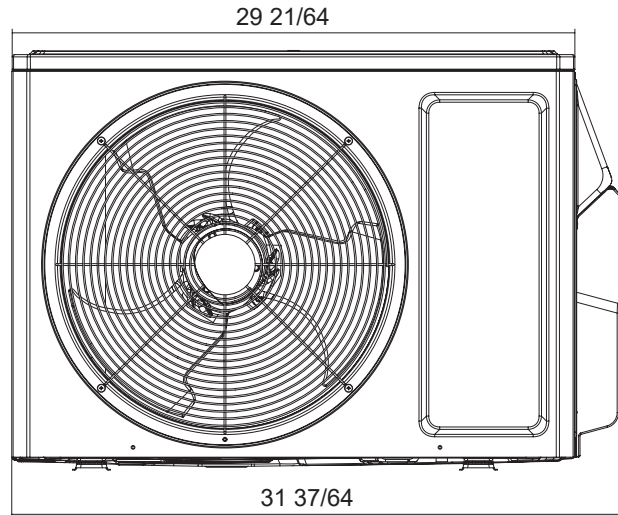
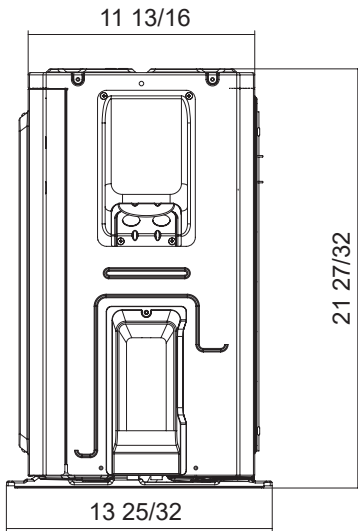

Liquid Line Valve	1/4-in OD Flared
Gas Line Valve	1/2-in OD Flared

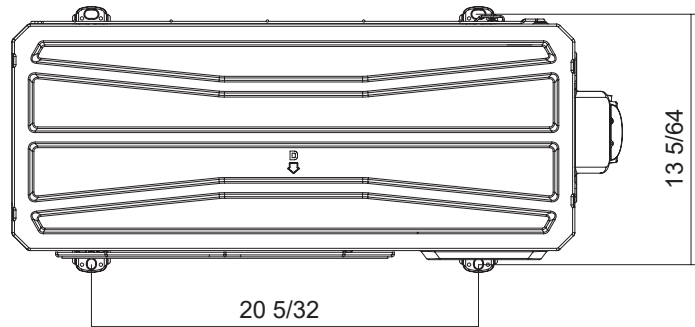

Dimensions Inch (mm)	9K-12K	18K	24K
H	21 27/32 (555)	25 63/64 (660)	25 63/64 (660)
W	31 37/64 (802)	37 23/32 (958)	37 23/32 (958)
D	13 50/64 (350)	15 53/64 (402)	15 53/64 (402)





Outline and Physical Dimensions

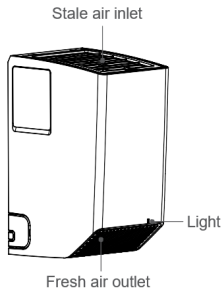

Model	\	XF30-SXQG01
Rated Voltage	Vdc	12
Power Input	W	13
Max Noise	dB(A)	42
Weight	Kg	1.8

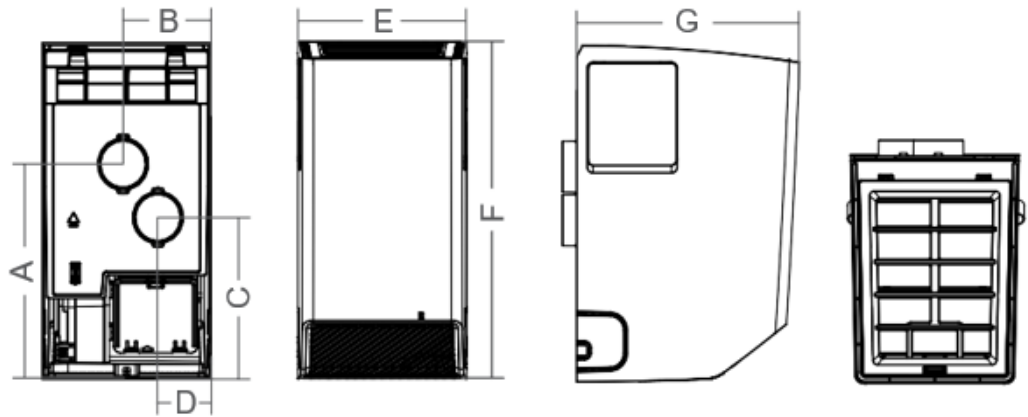

Millimeters (mm)	\	Inches (in)
187	A	7 3/8
79	B	3 1/8
141	C	5 9/16
49	D	1 15/16
151	E	5 5/16
293	F	11 17/32
200	G	7 7/8

