



SPLIT TYPE

CHARMO

Model:
KW09XQ19CAI
KW09XQ19CAO



- Auto-Clean function
- Dehumidification
- I-Feel function
- Self-diagnosis
- Multiple fan speeds
- Low Voltage start-up
- Swing louver control
- Intelligent Defrosting

Item	Unit	Parameter
AHRI number	\	216772299
Outdoor Model	\	KW09XQ19CAO
Indoor Model	\	KW09XQ19CAI
System Rating		
Cooling Capacity (95°F)	Btu/h	9100
Heating Capacity (47°F)	Btu/h	10000
Heating Capacity (17°F)	Btu/h	8100
Cooling Capacity Range	Btu/h	2700-11600
Heating Capacity Range	Btu/h	2400-12000
Power Supply	\	115V/1Ph/60Hz
SEER2	\	20.5
HSPF2	\	8.8
EER2	\	11.9
COP	\	3.66
Gas Pipe	inch (mm)	3/8 (9.52)
Liquid Pipe	inch (mm)	1/4 (6)
Standard Pipe Length	ft (M)	24.6 (7.5)
MIN. Refrigerant Pipe Length	ft (M)	10 (3)
MAX. Refrigerant Pipe Length	ft (M)	65 (20)
MAX. Vertical Height difference between Indoor and Outdoor	ft (M)	40 (12)
Connection Method	\	Screw Connection
Refrigerant Type	\	R32
Factory Charge	oz	18.7
Additional Charge	oz/ft	0.2
Pre-Charge Length	ft (M)	24.6 (7.5)
Controller Model	\	YBE1FB1F



Job Name:

Schedule Reference:

Date:



SPLIT TYPE

CHARMO

Model:
KW09XQ19CAI
KW09XQ19CAO



Indoor Unit Data		
Air Flow Volume	CFM (m ³ /h)	159~353 (270~600)
Sound Pressure Level	dB(A)	24~43
Dehumidification	pt/hr	1.69
Min/Max Voltage	V	103~126
Power supply	\	Powered from outdoor unit
Interconnecting wire	AWG	4/12
Dimension (HxWxD)	inch (mm)	10 53/64 x 32 7/8 x 7 7/8 (275 x 835 x 200)
Net Weight	lb (Kg)	19.8 (9)
Gross Weight	lb (Kg)	24.3 (11)
Outdoor Unit Data		
Compressor Type	\	Rotary
Compressor Oil	\	RB68GX
Compressor RLA	A	13.7
Sound Pressure Level	dB(A)	51
Min/Max Voltage	V	103~126
MCA	A	19
MOP	A	20
Dimension (HxWxD)	inch (mm)	21 27/32 x 28 13/16 x 12 63/64 (555 x 732 x 330)
Net Weight	lb (Kg)	55.1 (25)
Gross Weight	lb (Kg)	60.6 (27.5)
Operating Temperature for Cooling	°F/°C	0~118 (-18~48)
Operating Temperature for Heating	°F/°C	-13~75 (-25~24)

Job Name:

Schedule Reference:

Date:



Outline and Physical Dimensions

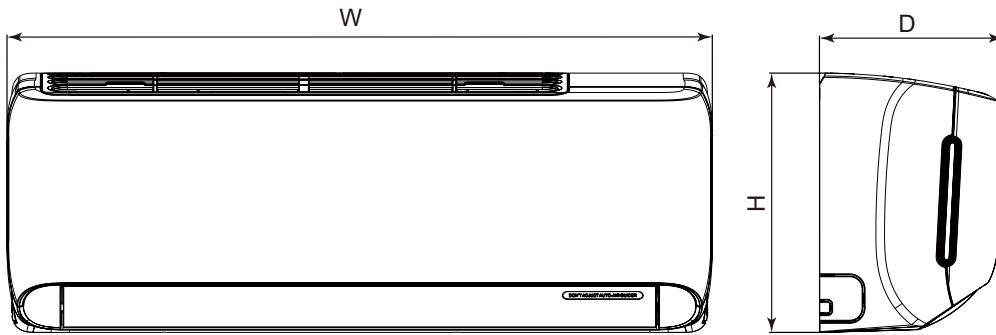

Dimensions Inch (mm)	9K-12K	18K	24K-30K-36K
H	10 53/64 (275)	13 7/64 (333)	13 7/64 (333)
W	32 7/8 (835)	37 1/8 (943)	42 7/16 (1078)
D	7 7/8 (200)	9 11/16 (246)	9 11/16 (246)

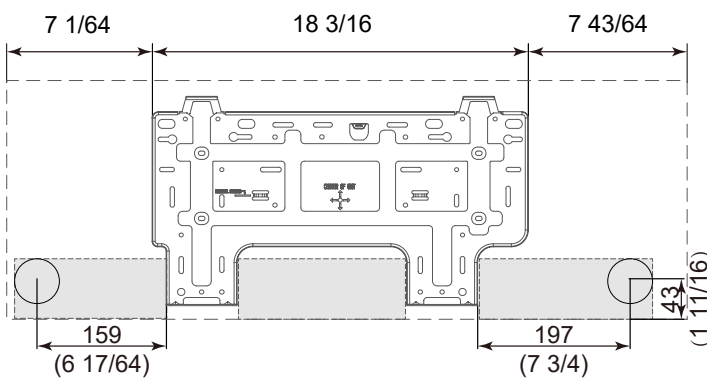

Liquid Line Valve	1/4-in OD Flared
Gas Line Valve	3/8-in OD Flared
Drain Connector	5/8-in OD





Outline and Physical Dimensions

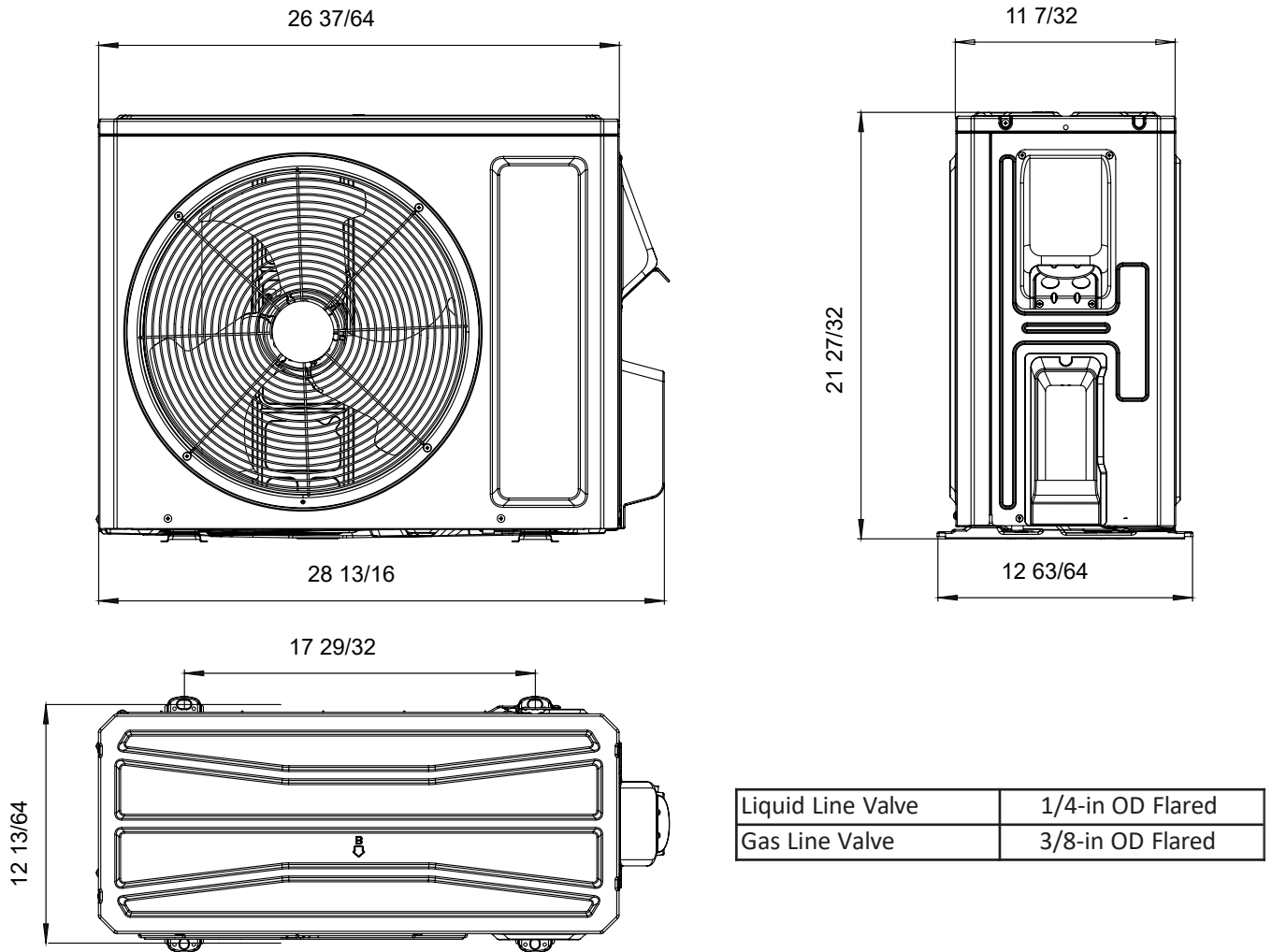

Dimensions Inch (mm)	9K-12K	18K	24K	30K-36K
H	21 27/32 (555)	21 27/32 (555)	25 63/64 (660)	29 3/8 (746)
W	28 13/16 (732)	31 37/64 (802)	37 23/32 (958)	39 3/8 (1000)
D	12 63/64 (330)	13 25/32 (350)	15 53/64 (402)	16 13/16 (427)

