



# SPLIT TYPE

# CHARMO

**Model:**  
**KW30XQ21CDI**  
**KW30XQ21CDO**



- Auto-Clean function
- Dehumidification
- I-Feel function
- Self-diagnosis
- Multiple fan speeds
- Low Voltage start-up
- Swing louver control
- Intelligent Defrosting

Item	Unit	Parameter
AHRI number	\	<b>216772294</b>
Outdoor Model	\	KW30XQ21CDO
Indoor Model	\	KW30XQ21CDI
System Rating		
Cooling Capacity (95°F)	Btu/h	30000
Heating Capacity (47°F)	Btu/h	30000
Heating Capacity (17°F)	Btu/h	24000
Cooling Capacity Range	Btu/h	7780-33000
Heating Capacity Range	Btu/h	9100-32000
Power Supply	\	208-230V/1Ph/60Hz
SEER2	\	22
HSPF2	\	9
EER2	\	10.9
COP	\	3.2
Gas Pipe	inch (mm)	5/8 (16)
Liquid Pipe	inch (mm)	1/4 (6)
Standard Pipe Length	ft (M)	24.6 (7.5)
MIN. Refrigerant Pipe Length	ft (M)	10 (3)
MAX. Refrigerant Pipe Length	ft (M)	131.2 (40)
MAX. Vertical Height difference between Indoor and Outdoor	ft (M)	82 (25)
Connection Method	\	Screw Connection
Refrigerant Type	\	R32
Factory Charge	oz	56.4
Additionnal Charge	oz	0.4
Pre-Charge Lenght	ft (M)	24.6 (7.5)
Controller Model	\	YBE1FB1F



Job Name:

Schedule Reference:

Date:



**SPLIT TYPE**

**CHARMO**

**Model:**  
**KW30XQ21CDI**  
**KW30XQ21CDO**



- Auto-Clean function
- Dehumidification
- I-Feel function
- Self-diagnosis
- Multiple fan speeds
- Low Voltage start-up
- Swing louver control
- Intelligent Defrosting

Indoor Unit Data		
Air Flow Volume	CFM (m <sup>3</sup> /h)	441~794 (750~1350)
Sound Pressure Level	dB(A)	35~52
Dehumidification	pt/hr	7.40
Min/Max Voltage	V	187-253
Power supply	\	Powered from outdoor unit
Interconnecting wire	AWG	4/12
Dimension (HxWxD)	inch (mm)	13 7/64 x 42 7/16 x 9 11/16 (333 x 1078 x 246)
Net Weight	lb (Kg)	34.2 (15.5)
Gross Weight	lb (Kg)	40.8 (18.5)
Outdoor Unit Data		
Compressor Type	\	Twin Rotary
Compressor Oil	\	RB68GX
Compressor RLA	A	18.5
Sound Pressure Level	dB(A)	62
Min/Max Voltage	V	187-253
MCA	A	30
MOP	A	27
Dimension (HxWxD)	inch (mm)	29 24/64 x 39 24/64 x 16 52/64 (746 x 1000 x 427)
Net Weight	lb (Kg)	116.8 (53)
Gross Weight	lb (Kg)	127.9 (58)
Operating Temperature for Cooling	°F/°C	-4~122 (-20~50)
Operating Temperature for Heating	°F/°C	-13~75 (-25~24)

Job Name:

Schedule Reference:

Date:



## Outline and Physical Dimensions

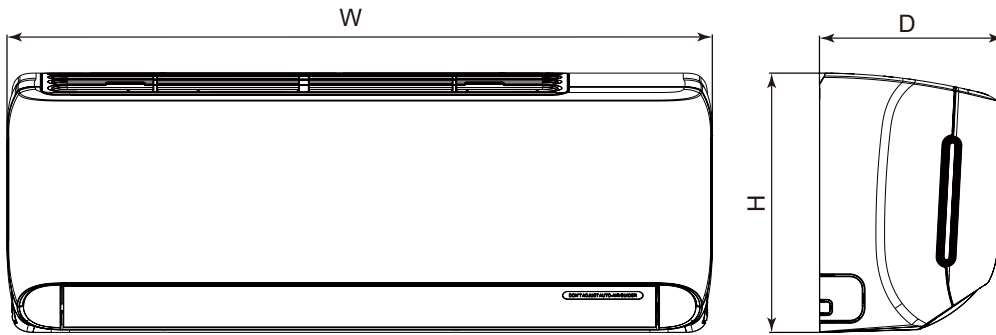

Dimensions Inch (mm)	9K-12K	18K	24K-30K-36K
H	10 53/64 (275)	13 7/64 (333)	13 7/64 (333)
W	32 7/8 (835)	37 1/8 (943)	42 7/16 (1078)
D	7 7/8 (200)	9 11/16 (246)	9 11/16 (246)

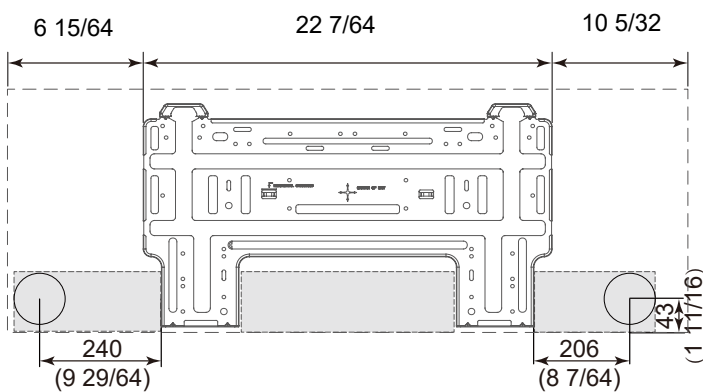

Liquid Line Valve	1/4-in OD Flared
Gas Line Valve	5/8-in OD Flared
Drain Connector	5/8-in OD





## Outline and Physical Dimensions

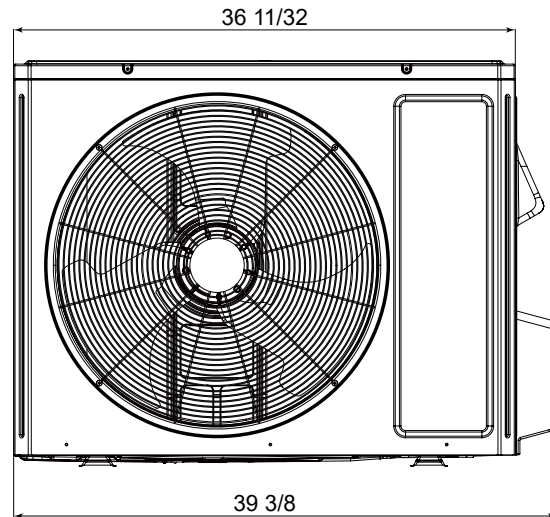
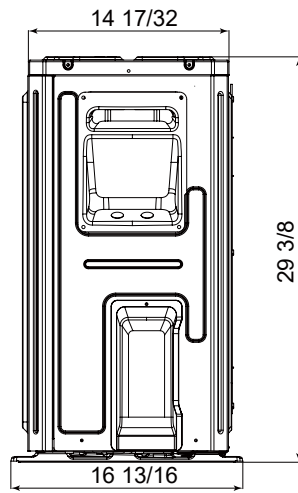

Liquid Line Valve	1/4-in OD Flared
Gas Line Valve	5/8-in OD Flared

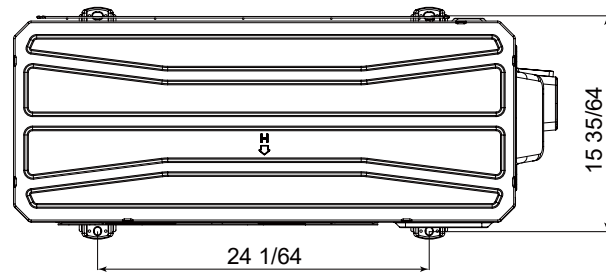

Dimensions Inch (mm)	9K-12K	18K	24K	30K-36K
H	21 27/32 (555)	21 27/32 (555)	25 63/64 (660)	29 3/8 (746)
W	28 13/16 (732)	31 37/64 (802)	37 23/32 (958)	39 3/8 (1000)
D	12 63/64 (330)	13 25/32 (350)	15 53/64 (402)	16 13/16 (427)

