



SPLIT TYPE

AIRY

Model:
KW24XQ29SDI
KW24XQ29SDO



- Auto-Clean function
- Dehumidification
- I-Feel function
- Self-diagnosis
- Precise airflow control
- Low Voltage start-up
- Swing louver control
- Intelligent Defrosting

Item	Unit	Parameter
AHRI number	\	215876650
Outdoor Model	\	KW24XQ29SDO
Indoor Model	\	KW24XQ29SDI
System Rating		
Cooling Capacity (95°F)	Btu/h	22000
Heating Capacity (47°F)	Btu/h	24000
Heating Capacity (17°F)	Btu/h	15000
Cooling Capacity Range	Btu/h	6800-31000
Heating Capacity Range	Btu/h	5800-32000
Power Supply	\	208-230V/1Ph/60Hz
SEER2	\	27
HSPF2	\	10
EER2	\	13.95
COP	\	3.91
Gas Pipe	inch (mm)	5/8 (16)
Liquid Pipe	inch (mm)	1/4 (6)
Standard Pipe Length	ft (M)	24.6 (7.5)
MIN. Refrigerant Pipe Length	ft (M)	10 (3)
MAX. Refrigerant Pipe Length	ft (M)	131.2 (40)
MAX. Vertical Height difference between Indoor and Outdoor	ft (M)	82 (25)
Connection Method	\	Screw Connection
Refrigerant Type	\	R32
Factory Charge	oz	56.4
Additional Charge	oz	0.4
Pre-Charge Length	ft (M)	24.6 (7.5)
Controller Model	\	YBE1FB9F



Job Name:

Schedule Reference:

Date:



SPLIT TYPE

AIRY

Model:
KW24XQ29SDI
KW24XQ29SDO



Indoor Unit Data		
Air Flow Volume	CFM (m ³ /h)	353~765 (600~1300)
Sound Pressure Level	dB(A)	36~53
Dehumidification	pt/hr	7.40
Min/Max Voltage	V	187-253
MCA	A	Powered from ODU
MOP	A	Powered from ODU
Dimension (HxWxD)	inch (mm)	13 21/32 x 43 45/64 x 10 1/8 (347 x 1110 x 257)
Net Weight	lb (Kg)	39.7 (18)
Gross Weight	lb (Kg)	46.3 (21)
Outdoor Unit Data		
Compressor Type	\	Rotary
Compressor Oil	\	FW68DA
Compressor RLA	A	18
Sound Pressure Level	dB(A)	62
Min/Max Voltage	V	187~253
MCA	A	25.5
MOP	A	30
Dimension (HxWxD)	inch (mm)	29 3/8 x 39 3/8 x 16 13/16 (746 x 1000 x 427)
Net Weight	lb (Kg)	115.8 (52.5)
Gross Weight	lb (Kg)	126.8 (57.5)
Operating Temperature for Cooling	°F/°C	-20~122 (-29~50)
Operating Temperature for Heating	°F/°C	-22~86 (-30~30)

Job Name:

Schedule Reference:

Date:

Specification are subject to change without notice.



Outline and Physical Dimensions

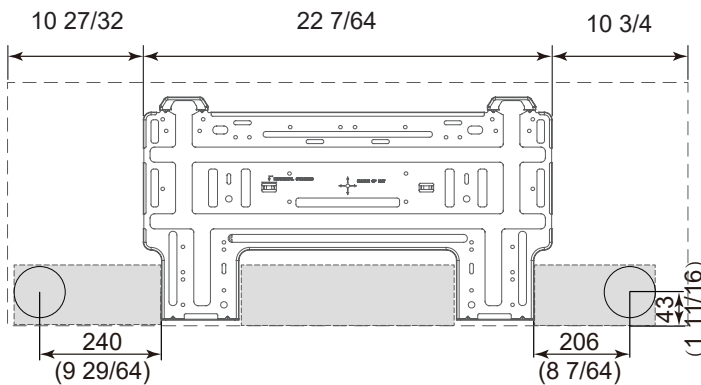
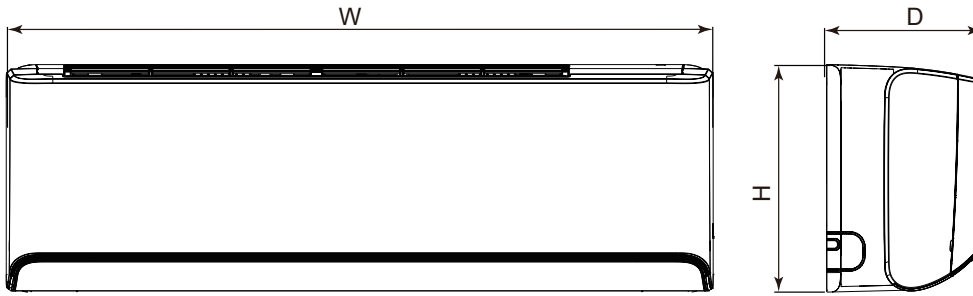

Dimensions Inch (mm)	9K-12K	18K	24K
H	13 $\frac{21}{32}$ (347)	13 $\frac{21}{32}$ (347)	13 $\frac{21}{32}$ (347)
W	38 $\frac{3}{16}$ (970)	43 $\frac{45}{64}$ (1110)	43 $\frac{45}{64}$ (1110)
D	10 $\frac{1}{8}$ (257)	10 $\frac{1}{8}$ (257)	10 $\frac{1}{8}$ (257)



Liquid Line Valve	1/4-in OD Flared
Gas Line Valve	5/8-in OD Flared
Drain Connector	5/8-in OD



Outline and Physical Dimensions

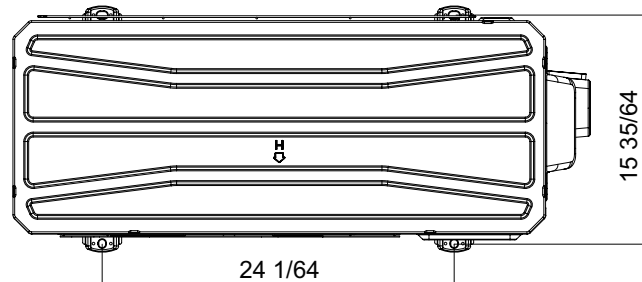
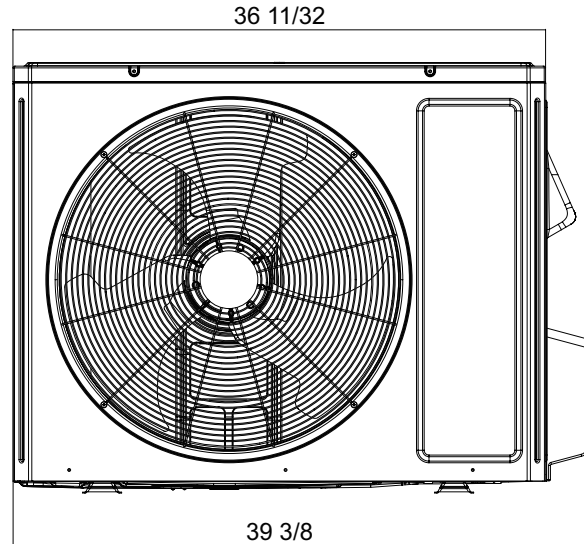
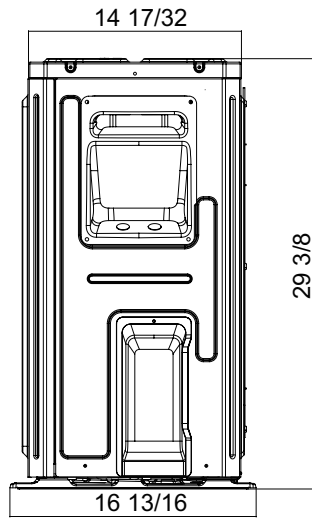

Liquid Line Valve	1/4-in OD Flared
Gas Line Valve	5/8-in OD Flared

Dimensions Inch (mm)	9K-12K	18K	24K
H	21 27/32 (555)	25 63/64 (660)	29 3/8 (746)
W	34 3/8 (873)	37 23/32 (958)	39 3/8 (1000)
D	14 51/64 (376)	15 53/64 (402)	16 13/16 (427)

