



SPLIT TYPE

MULTIZONE

**Model:
KM18X60**



Item	Unit	Parameter
AHRI number	\	215708441
Outdoor Model	\	KM18X60
Indoor Match	\	Non-Ducted
System Rating		
Cooling Capacity	Btu/h	18000
Heating Capacity	Btu/h	18000
Power Supply	\	208-230V/1Ph/60Hz
SEER2	\	21
EER2	\	12
HSPF2	\	10
Gas Pipe 1	inch (mm)	3/8 (9.52)
Liquid Pipe 1	inch (mm)	1/4 (6)
Gas Pipe 2	inch (mm)	3/8 (9.52)
Liquid Pipe 2	inch (mm)	1/4 (6)
Connection Pipe MAX. Height Distance (Indoor/Indoor)	ft (M)	49.2 (15)
Connection Pipe MAX. Height Distance (Indoor UP/Outdoor)	ft (M)	49.2 (15)
Connection Pipe MAX. Height Distance (Indoor/Outdoor UP)	ft (M)	49.2 (15)
MAX. Equivalent Connection Pipe Length (Outdoor/Last Indoor)	ft (M)	65.6 (20)
Connection Pipe MAX. Length Distance (Total Length)	ft (M)	131.2 (40)
Connection Method	\	Screw Connection
No Additionnal Gas Connection Pipe Length	ft (M)	32.8 (10)
Connection Pipe Length Additional Charge	oz/ft.	0.2
Refrigerant Type	\	R32
Refrigerant Charge	oz	31.75



Pair with any two indoor units.
*Indoor unit photos are for reference only.

Job Name:

Schedule Reference:

Date:



SPLIT TYPE

MULTIZONE

**Model:
KM18X6O**



Outdoor Unit Data		
Sound Pressure Level	dB(A)	54
Min/Max Voltage	V	187-253
MCA	A	14.5
MOP	A	20
Dimension (HxWxD)	inch (mm)	21 21/32 x 32 23/64 x 13 55/64 (550 x 822 x 352)
Dimension Package (HxWxD)	inch (mm)	24 26/64 x 34 21/64 x 15 43/64 (620 x 872 x 398)
Net Weight	lb (Kg)	78.3 (35.5)
Gross Weight	lb (Kg)	84.9 (38.5)
Operating Temperature for Cooling	°F/°C	-22~118 (-30~48)
Operating Temperature for Heating	°F/°C	-22~75.2 (-30~24)

- Indoor units powered by Outdoor unit
- Small footprint design
- G-10 inverter technology
- Self-diagnosis
- Quiet operation
- Multiple Indoor unit configuration
- Swing louver control
- Intelligent Defrosting
- Blue Fin Colored 500 Hrs Salt Spray Tested
- A2L Refrigerant sensor included

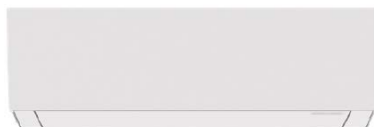

Job Name:

Schedule Reference:

Date:



Outline and Physical Dimensions

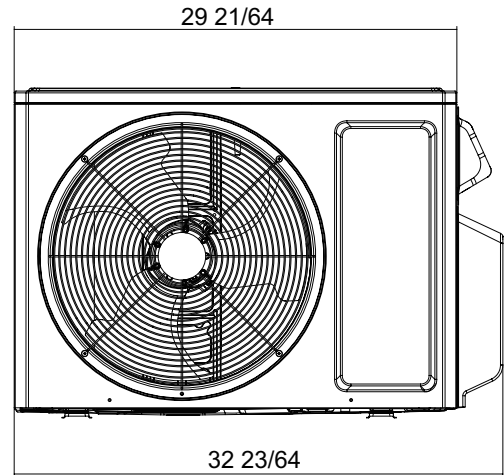
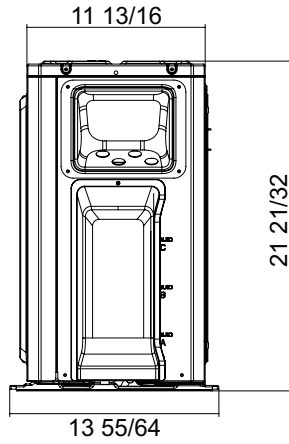

Liquid Line Valve 1	1/4-in OD Flared
Gas Line Valve 1	3/8-in OD Flared
Liquid Line Valve 2	1/4-in OD Flared
Gas Line Valve 2	3/8-in OD Flared

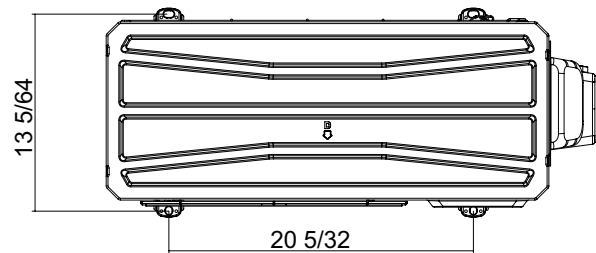

Dimensions Inch (mm)	18K	24K	30K-36K-42K
H	21 21/32 (550)	25 63/64 (660)	32 33/64 (826)
W	32 23/64 (822)	37 61/64 (964)	40 5/32 (1020)
D	13 55/64 (352)	15 53/64 (402)	16 13/16 (427)

