

MODEL : XE71-00/E

This controller suitable for:

- High wall Type, Ducted Unit Type, Cassette Type, Floor/ceiling Type

Smart control :

- Advanced algorithms make smart switch between heat pump and the third-party heater, to increase saving and optimize confort.

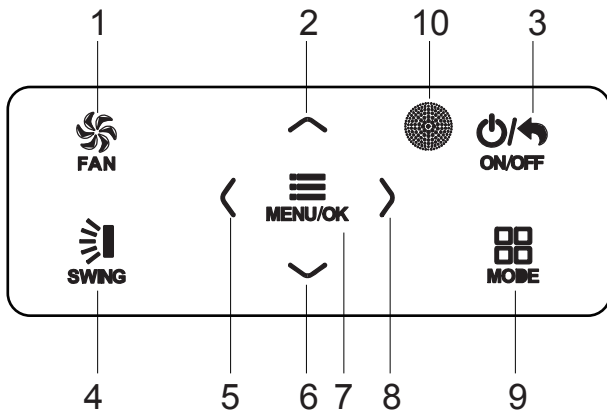

No.	Button name	Button Function
1	FAN	Set low speed, medium speed, high speed, turbo and auto speed.
2	^	(1) Set temperature (2) Set parameter
6	v	(3) Move option cursor
3	ON/OFF/BACK	(1) Turn on or turn off unit (2) Return to last page
4	SWING	Set up&down swing and set left&right swing
5	<	(1) Set related function on or off (2) Move option cursor
8	>	(3) Set parameter
7	MENU/OK	(1) Enter menu page (2) Confirm setting
9	MODE	Set auto, cooling, dry, fan, aux heat and heating modes for indoor unit.
10	Remote control receiver window	

Job Name:

Schedule Reference:

Date:



Outline and Physical Dimension of XE71-00/E.

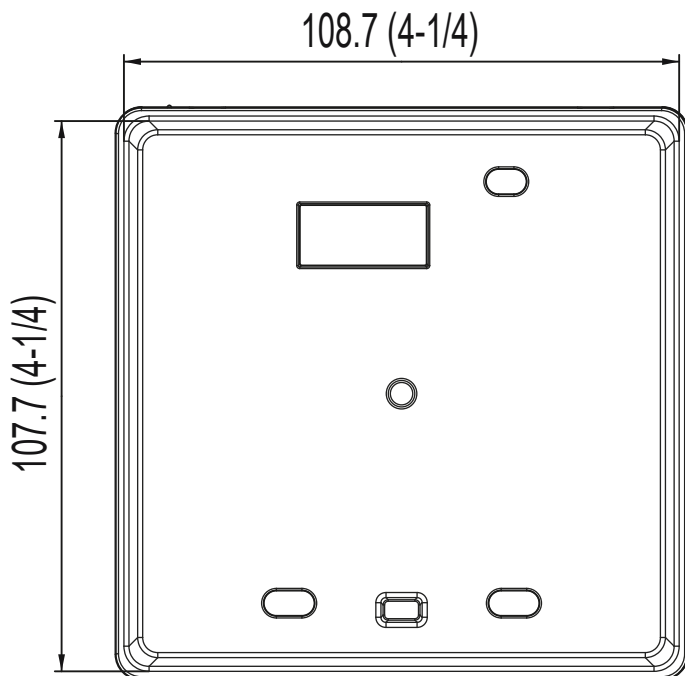
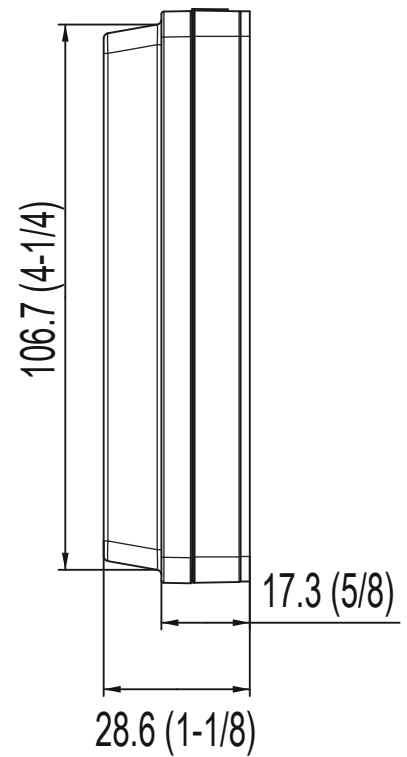
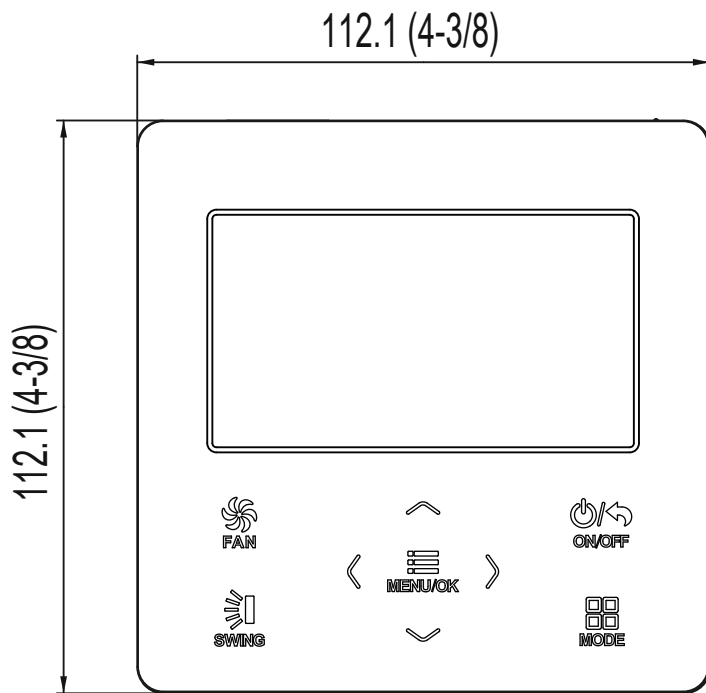

Unit outline dimension: mm (in.)

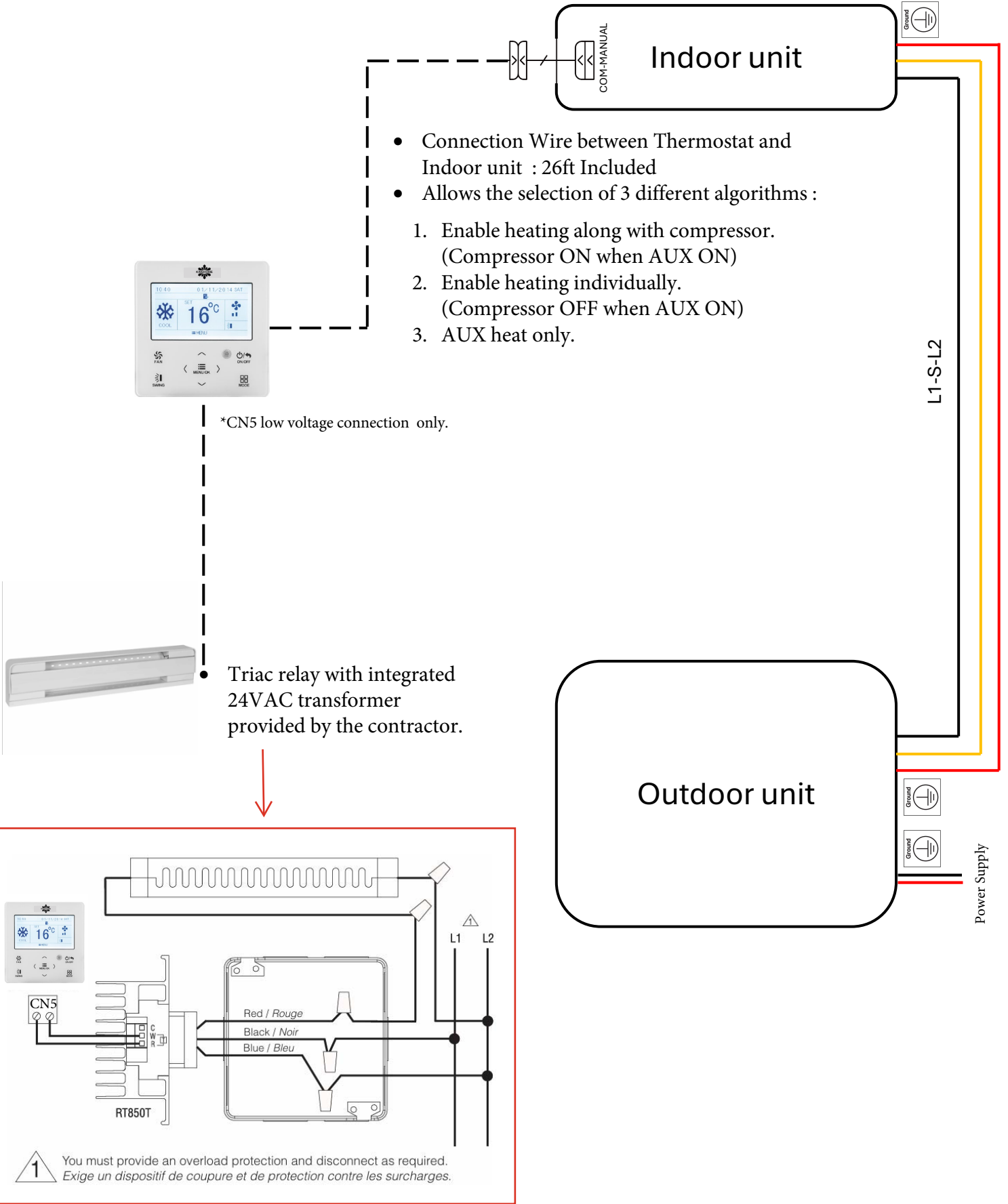

*Field connection could vary.