



Cold Climate Heat Pump

QUICK START GUIDE

Thank you for choosing our product.
Please read this Quick Start Guide carefully before
operation and retain it for future reference.

PLEASE READ FIRST

Although very similar to traditional unitary heat pump systems, the ULTRANIXX Heat Pump Systems have a few key installation differences.

- 1. Each outdoor unit has two capacity and blower settings available on their corresponding control boards. (Detailed on the next page)**
 - The 36kBtu models are rated for either 24kBtu or 36kBtu, nominal.
 - The 60kBtu models are rated for either 48kBtu or 60kBtu, nominal.
 - The efficiency ratings may change with a change in the capacity rating.
 - The outdoor and indoor capacities must match.
- 2. Both outdoor and indoor units feature service (shut-off) valves on both the liquid and gas (suction) valves.**
 - The indoor unit does not contain a nitrogen charge, but a small amount (0.55lbs) of R-410A refrigerant.
 - Do not release this refrigerant to the atmosphere.
 - When evacuating (pulling a vacuum), **pull from both the liquid and gas (suction) valves.** This will ensure a proper evacuation has been performed and no air or other contaminants are in the refrigeration system. This will also mean proper evacuation takes less time.
- 3. The “W1” terminal activates the electric heat kit (if equipped).**
 - The W1 terminal must be connected at the indoor and outdoor unit, and at the thermostat.
 - The heat kit is activated during defrost by the outdoor unit’s “D” terminal.
 - For a heat pump application, not straight cooling or dual fuel, the “W1” control wire will connect to “W2” or “AUX” on the thermostat
- 4. This system contains PVE oil, not POE. Cross-contamination is prohibited.**
 - Replace or flush existing line sets and/or coils in a retrofit application

 **DO NOT DISCARD. STORE THIS INFORMATION IN A SAFE PLACE FOR FUTURE REFERENCE.**

OUTDOOR UNIT DIP SWITCH SETTINGS

NOTE

- ULTRANIXX outdoor units are configurable by a set of dip switches located in the upper right hand corner of the Main Control Board.
- By default, the capacity is set at the larger capacity. Defrost, Power Mode, and Energy Savings are all set for the Standard, by default.
- Power must be shut off prior to changing the dip switch settings.
- The outdoor unit capacity must match the indoor unit capacity. The Power Mode and Energy Saving modes cannot be set simultaneously.

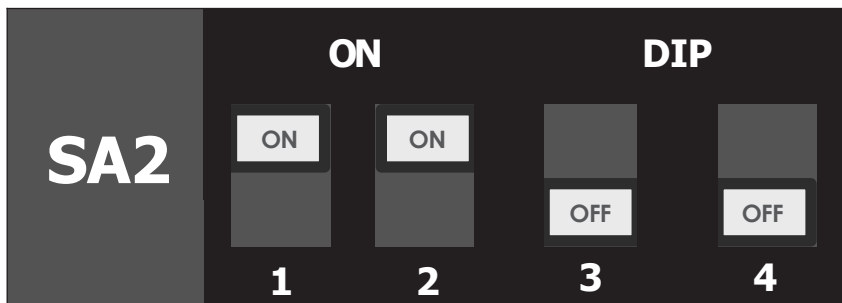

NOTE

The ON position of the switch is towards the word "ON" located on the dip switch bank for the ULTRANIXX outdoor unit.

Capacity		DIP#1	Capacity		DIP#1
KU36UHO	36kBtu Configuration (Default)		KU60UHO	60kBtu Configuration (Default)	
	24kBtu Configuration			48kBtu Configuration	

Defrost		DIP#2	Operating Modes		DIP#3	DIP#4
KU36UHO KU60UHO	Standard (Default)		KU36UHO KU60UHO	Standard (Default)		
	Strong Defrost			Energy Saving		
				Strong Mode		

DEFROST

- **Standard Defrost Mode** is the default setting from the factory.
- **Strong Defrost Mode** is used in cold but high humidity environments such as areas near large bodies of water. Select Strong Defrost Mode if it is common practice to extend defrost timing or increase the frequency of defrost cycles in the area where the system is installed.
- In other cases where Standard Defrost Mode has been deemed insufficient, ensure the system is in good working order, the outdoor coil is clean, and the system is charged properly before changing the defrost setting to Strong Defrost Mode.

STRONG MODE

- In **Strong Defrost Mode**, the compressor will increase its speed at a higher rate than in **Standard Defrost Mode**, to reduce the ramp up time.
- **Strong Defrost Mode** may be enabled if **Standard Defrost Mode** is deemed insufficient by the customer but note it is less efficient.
- Always ensure the system is in good working order before enabling **Strong Defrost Mode**.

ENERGY SAVING MODE

- In **Energy Saving Mode**, the compressor will increase its speed at a lower slower rate. This can increase efficiency of the unit and provide additional dehumidification than the **Standard** or **Strong** modes.
- Example: **Energy Saving Mode** may be used when the new system is replacing a system that was a half-ton smaller than the ULTRANIXX being installed. (The ULTRANIXX is not available in 1.5, 2.5 or 3.5 ton capacities, therefore ULTRANIXX would be set for the next highest capacity such as 2, 3 or 4 ton.)
- The indoor CFM rating should also be reduced to match a normal CFM rating for the half-ton system design. This would mean that the set point would most likely be satisfied before reaching the system's full rated nominal capacity, reducing energy usage and improving dehumidification in cooling mode.

NOTE

Strong Mode and Energy Saving Mode cannot be enabled at the same time. Only one mode can be enabled.

REFRIGERANT CHARGING

- It is recommended to install a new 3/8" X 3/4" line set.
- Filter driers are not recommended. Follow industry best practices for refrigerant piping.

UTRANIXX 2/3 Ton – KU36UHO				ULTRANIXX 4/5 Ton – KU60UHO			
Model	Add:	Total Length of Line Set:	Add:	Model	Add:	Total Length of Line Set:	Add:
Less than 31 Feet	None	96 to 98 Feet	1 lb 7 Oz.	Less than 31 Feet	None	65 to 67 Feet	13 Oz.
32 Feet	2 Oz.	99 to 101 Feet	1 lb 8 Oz.	32 Feet	2 Oz.	68 to 70 Feet	14 Oz.
33 to 35 Feet	3 Oz.	102 to 104 Feet	1 lb 9 Oz.	33 to 35 Feet	3 Oz.	71 to 73 Feet	15 Oz.
36 to 39 Feet	4 Oz.	105 to 107 Feet	1 lb 10 Oz.	36 to 39 Feet	4 Oz.	74 to 76 Feet	1 lb
40 to 42 Feet	5 Oz.	108 to 110 Feet	1 lb 11 Oz.	40 to 42 Feet	5 Oz.	77 to 79 Feet	1 lb 1 Oz.
43 to 45 Feet	6 Oz.	111 to 114 Feet	1 lb 12 Oz.	43 to 45 Feet	6 Oz.	80 to 82 Feet	1 lb 2 Oz.
46 to 48 Feet	7 Oz.	115 to 117 Feet	1 lb 13 Oz.	46 to 48 Feet	7 Oz.	83 to 85 Feet	1 lb 3 Oz.
49 to 51 Feet	8 Oz.	118 to 120 Feet	1 lb 14 Oz.	49 to 51 Feet	8 Oz.	86 to 89 Feet	1 lb 4 Oz.
52 to 54 Feet	9 Oz.	121 to 123 Feet	1 lb 15 Oz.	52 to 54 Feet	9 Oz.	90 to 92 Feet	1 lb 5 Oz.
55 to 57 Feet	10 Oz.	124 to 126 Feet	2 lb	55 to 57 Feet	10 Oz.	93 to 95 Feet	1 lb 6 Oz.
58 to 60 Feet	11 Oz.	127 to 129 Feet	2 lb 1 Oz.	58 to 60 Feet	11 Oz.	96 to 98 Feet	1 lb 7 Oz.
61 to 64 Feet	12 Oz.	130 to 132 Feet	2 lb 2 Oz.	61 to 64 Feet	12 Oz.		
65 to 67 Feet	13 Oz.	133 to 135 Feet	2 lb 3 Oz.	98 Feet is Max. Length			
68 to 70 Feet	14 Oz.	136 to 139 Feet	2 lb 4 Oz.				
71 to 73 Feet	15 Oz.	140 to 142 Feet	2 lb 5 Oz.				
74 to 76 Feet	1 lb	143 to 145 Feet	2 lb 6 Oz.				
77 to 79 Feet	1 lb 1 Oz.	146 to 148 Feet	2 lb 7 Oz.				
80 to 82 Feet	1 lb 2 Oz.	149 to 151 Feet	2 lb 8 Oz.				
83 to 85 Feet	1 lb 3 Oz.	152 to 154 Feet	2 lb 9 Oz.				
86 to 89 Feet	1 lb 4 Oz.	155 to 157 Feet	2 lb 10 Oz.				
90 to 92 Feet	1 lb 5 Oz.	158 to 160 Feet	2 lb 11 Oz.				
93 to 95 Feet	1 lb 6 Oz.	161 to 164 Feet	2 lb 12 Oz.				
164 Feet is Max. Length							

COLD WEATHER STARTUP

The UTRANIXX outdoor unit is factory equipped with a crankcase heater.

- In outdoor temperatures below 32°F (0°C), ensure that power is applied to the outdoor unit for a minimum of 8 hours prior to startup.
- Upon power application, check the operation of the crankcase heater by removing the front access panel, opening the compressor blanket, and checking to see if the crankcase heater is hot.
- The crankcase heater ensures that liquid refrigerant is not present in the compressor before startup.
- Liquid refrigerant is not compressible and will force the compressor oil out of the compressor. This will damage the compressor.

INSTALLATION TIP

To make the best use of the 8 hour preheat, do the following:

1. Set the outdoor and indoor units
2. Install the refrigerant piping
3. Perform a leak check
4. Pull a 500 micron vacuum
5. Connect line voltage to the outdoor unit
6. Weigh in additional charge, if needed
7. Open the indoor and outdoor shutoff valves
8. Power on the outdoor unit
9. Complete all other installation items once power is applied to the outdoor unit

ELECTRIC HEAT KIT PRECAUTIONS

⚠ ANY FIELD WIRING, IF PRESENT, ON L1/L2 MUST BE DISCONNECTED PERMANENTLY PRIOR TO HEAT KIT INSTALLATION!

ALL POWER FOR THE AIR HANDLER WILL BE PROVIDED THROUGH THE HEAT KIT BREAKER!

FAILURE TO DISCONNECT ALL FIELD WIRING ON THE L1/L2 TERMINAL CAN RESULT IN FIRE!

AIR HANDLER DIP SWITCH SETTINGS

NOTE

- The ULTRANIXX Air Handlers are configurable by a set of dip switches located on the main control board. For proper operation, ensure that the air handler blower settings match the outdoor unit capacity and ducting design. Power must be off prior to changing the dip switch settings.
- There are 8 static pressure settings for the blower.
- Air handler's control box Dip Switches are located on the Main Control Board inside the air handler control box.
- By default, the blower is set at Speed 4.
- Dip switch settings are on the following two pages.
- As with all air handling equipment, a duct system with a design that exceeds the capabilities of the installed equipment will result in customer discomfort, limited performance, and reduced equipment life.

AIR HANDLER DIP SWITCH SETTINGS (Continued)

NOTE

- Only the "HEAT (SA2)" dip switches are adjusted.
- The "COOL (SA1)" dip switches must remain in the "ON" position.

Model	KU24UH2I		Model	KU36UH2I	
	HEAT (SA2)	COOL (SA1)		HEAT (SA2)	COOL (SA1)
Speed 1			Speed 1		
Speed 2			Speed 2		
Speed 3			Speed 3		
Speed 4			Speed 4		
Speed 5			Speed 5		
Speed 6			Speed 6		
Speed 7			Speed 7		
Speed 8			Speed 8		

AIR HANDLER DIP SWITCH SETTINGS (Continued)

Model	KU48UH2I		Model	KU60UH2I	
	HEAT (SA2)	COOL (SA1)		HEAT (SA2)	COOL (SA1)
Speed 1			Speed 1		
Speed 2			Speed 2		
Speed 3			Speed 3		
Speed 4			Speed 4		
Speed 5			Speed 5		
Speed 6			Speed 6		
Speed 7			Speed 7		
Speed 8			Speed 8		

CHECKING STATIC PRESSURE

To properly utilize the below fan charts it is required to determine Total Static.

- Supply static must be measured in the supply trunk after the air handler and before branch ducts or registers in the airflow stream as shown in the figure above
- Return static must be measured in the return trunk towards the air handler after any branch returns, return grilles or filters
- Keep in mind static pressure drop will increase with a wet coil (cooling mode) vs dry coil (fan on or heating mode)

NOTE

- Total static includes everything the air handler is working against, supply duct return duct, branch duct, register boots, elbows, filter grille, filter and so on.
- Total Static is the difference between supply positive pressure and return negative pressure.

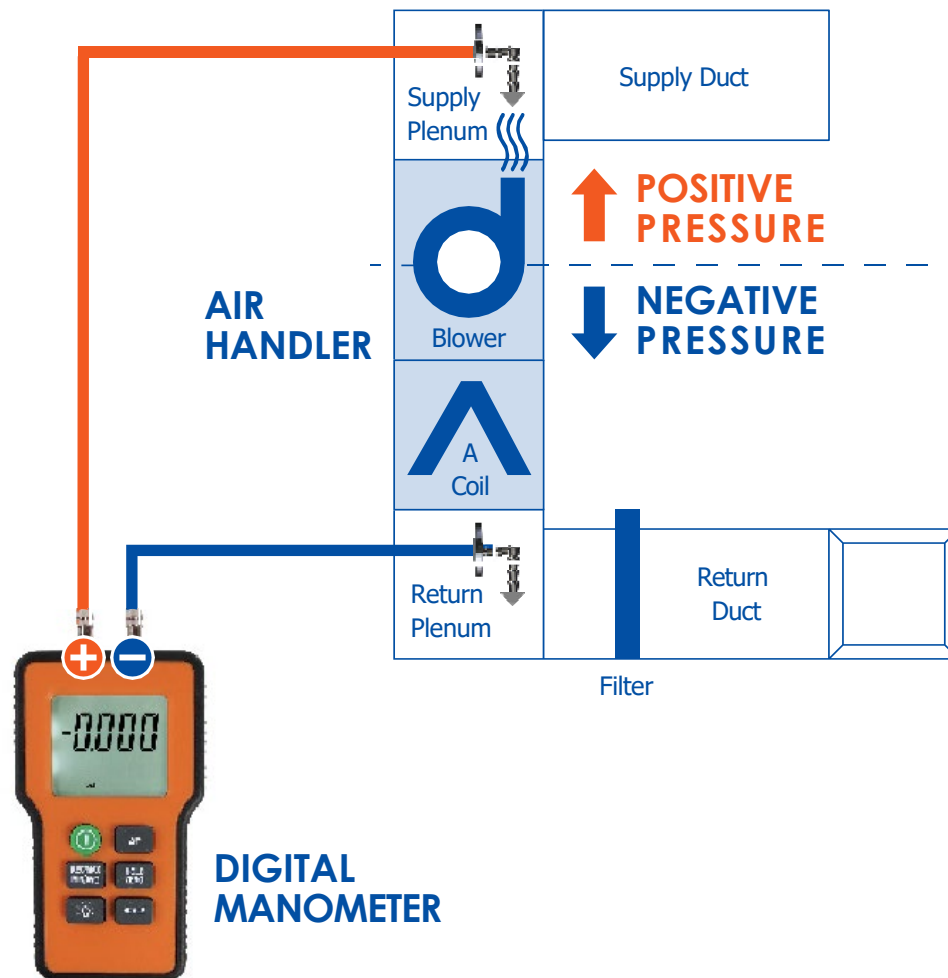

AIR HANDLER AIRFLOW RATINGS

The following CFM ratings are with a dry coil and included filter. For wet coil ratings, use 0.92 as the correction factor for the CFM.

Model	KU24UH2I											
Level	Static Pressure (In W.c.) and CFM											
	0	0.1	0.15	0.2	0.3	0.4	0.5	0.6	0.7	0.8	0.9	1.0
Speed 1	1030	900	840	-	-	-	-	-	-	-	-	-
Speed 2	1080	960	900	840	-	-	-	-	-	-	-	-
Speed 3	1220	1120	1060	990	850	-	-	-	-	-	-	-
Speed 4	1390	1290	1240	1180	1070	960	-	-	-	-	-	-
Speed 5	1580	1490	1440	1390	1290	1180	1090	970	830	-	-	-
Speed 6	1720	1640	1600	1550	1450	1360	1250	1130	960	-	-	-
Speed 7	1800	1730	1680	1630	1550	1460	1370	1270	1150	970	830	-
Speed 8	1850	1820	1790	1740	1660	1580	1500	1410	1340	1200	1080	930

Model	KU36UH2I											
Level	Static Pressure (In W.c.) and CFM											
	0	0.1	0.15	0.2	0.3	0.4	0.5	0.6	0.7	0.8	0.9	1.0
Speed 1	1150	1050	950	880	-	-	-	-	-	-	-	-
Speed 2	1200	1100	1000	940	850	-	-	-	-	-	-	-
Speed 3	1380	1260	1200	1100	950	-	-	-	-	-	-	-
Speed 4	1550	1460	1390	1310	1160	1010	830	-	-	-	-	-
Speed 5	1710	1650	1600	1560	1480	1400	1310	1210	1080	930	-	-
Speed 6	1840	1800	1750	1710	1640	1590	1500	1420	1330	1220	1100	960
Speed 7	1870	1830	1810	1800	1760	1690	1620	1520	1440	1350	1250	1150
Speed 8	1900	1860	1840	1830	1790	1720	1660	1600	1540	1440	1320	1220

AIR HANDLER AIRFLOW RATINGS (Continued)

Model	KU48UH2I											
Level	Static Pressure (In W.c.) and CFM											
	0	0.1	0.15	0.2	0.3	0.4	0.5	0.6	0.7	0.8	0.9	1.0
Speed 1	1640	1500	1450	1350	-	-	-	-	-	-	-	-
Speed 2	1680	1560	1500	1380	1300	-	-	-	-	-	-	-
Speed 3	1810	1690	1620	1550	1380	-	-	-	-	-	-	-
Speed 4	1930	1830	1770	1710	1580	1430	1280	-	-	-	-	-
Speed 5	2200	2110	2040	1980	1860	1720	1620	1490	1380	-	-	-
Speed 6	2240	2190	2145	2100	2010	1870	1750	1615	1500	1380	-	-
Speed 7	2280	2240	2200	2180	2130	2080	2000	1880	1750	1600	1420	-
Speed 8	2300	2260	2220	2190	2140	2090	2040	1980	1930	1800	1700	1550

Model	KU60UH2I											
Level	Static Pressure (In W.c.) and CFM											
	0	0.1	0.15	0.2	0.3	0.4	0.5	0.6	0.7	0.8	0.9	1.0
Speed 1	1660	1540	1470	1400	-	-	-	-	-	-	-	-
Speed 2	1850	1720	1650	1600	1400	-	-	-	-	-	-	-
Speed 3	1920	1800	1730	1650	1480	1315	-	-	-	-	-	-
Speed 4	2110	2000	1950	1860	1760	1640	1490	1325	-	-	-	-
Speed 5	2250	2200	2190	2140	2040	1930	1800	1670	1520	1370	-	-
Speed 6	2260	2220	2200	2170	2090	2010	1910	1760	1650	1550	1430	1380
Speed 7	2300	2260	2230	2200	2150	2115	2050	1990	1920	1840	1750	1660
Speed 8	2320	2280	2250	2230	2190	2140	2080	2040	2000	1950	1920	1890

FIELD INSTALLED TRANSITION

It is recommended to add a Field-installed Transition when the coil does not have same dimensions as the furnace. Please see the illustration below.

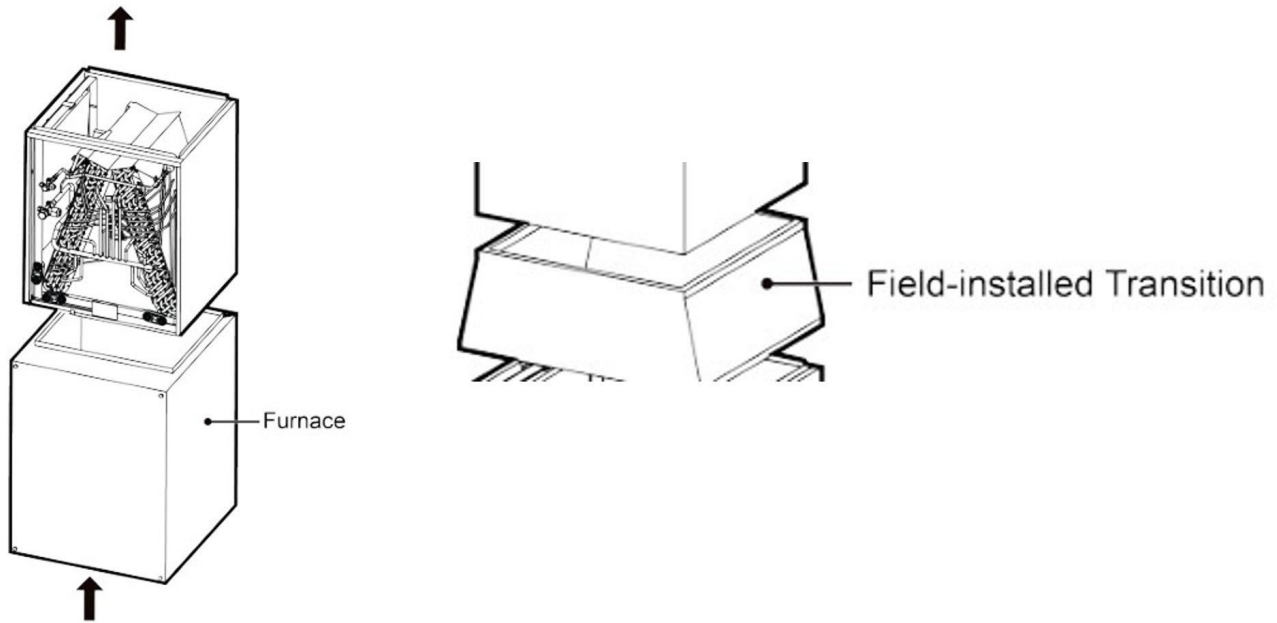

NOTE

Adding a proper Field-installed Transition will ensure proper airflow across the entire coil and allow space for inspecting the coil and heat exchanger. A minimum of 2inch is required between the heat exchanger and the A coil.

24V CONTROL WIRING SCHEMATIC

Thermostat wiring without heat kit

Blower shutdown during defrost

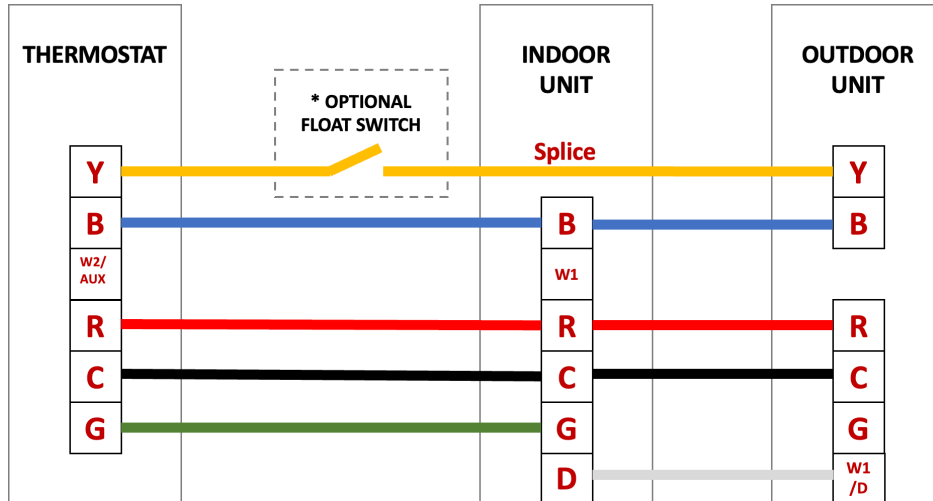

NOTE

Blower shuts down during defrost to prevent cold air in the space.

Thermostat wiring with heat kit

Blower shutdown during defrost

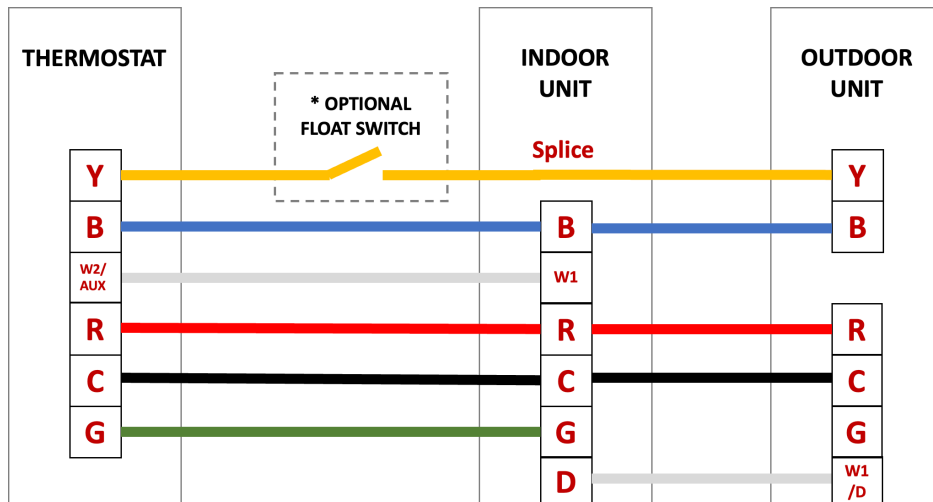

NOTE

Blower shuts down and heat kit does not activate.

Thermostat wiring with heat kit
 Activate heat kit during defrost

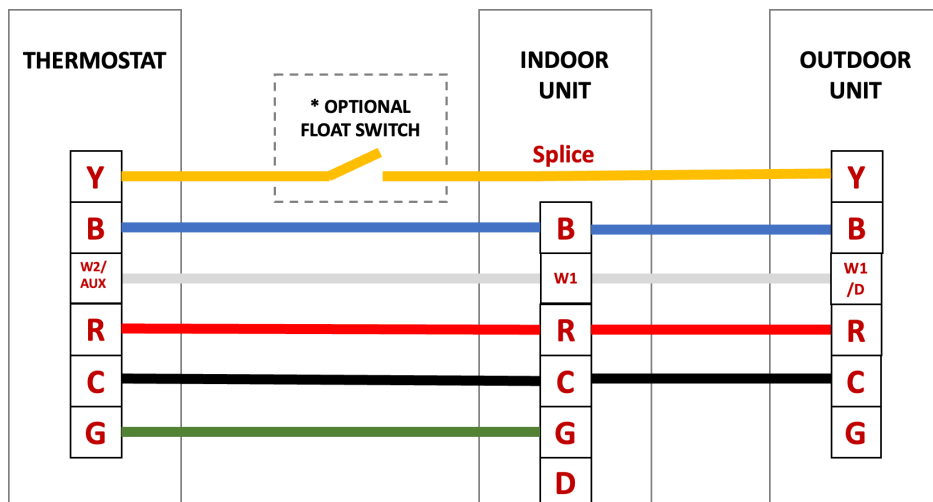

NOTE

Heat kit and blower runs during defrost.

Thermostat wiring for Dual Fuel

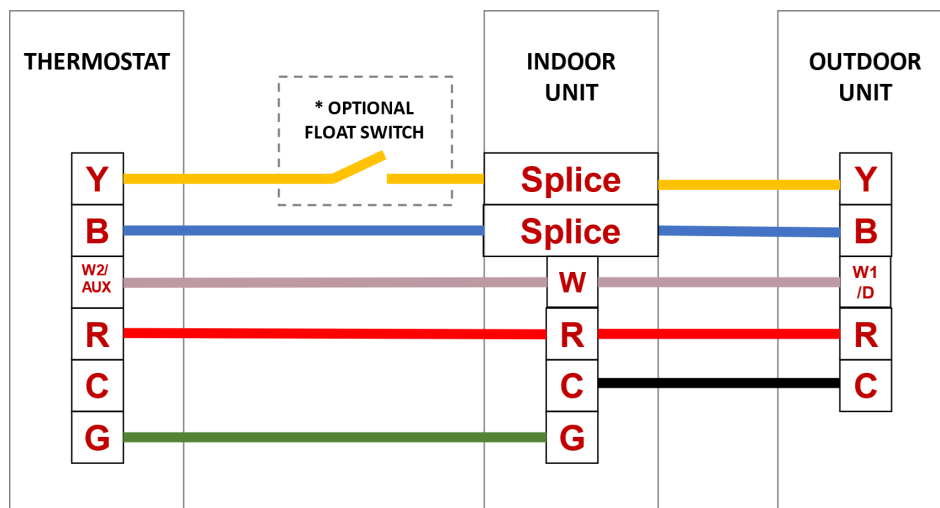

NOTE

Dual Fuel Capable Thermostat is required so that the Furnace and the Heat Pump cannot run at the same time other than when the Heat Pump is in defrost.

Ultrnixx

Cooling mode

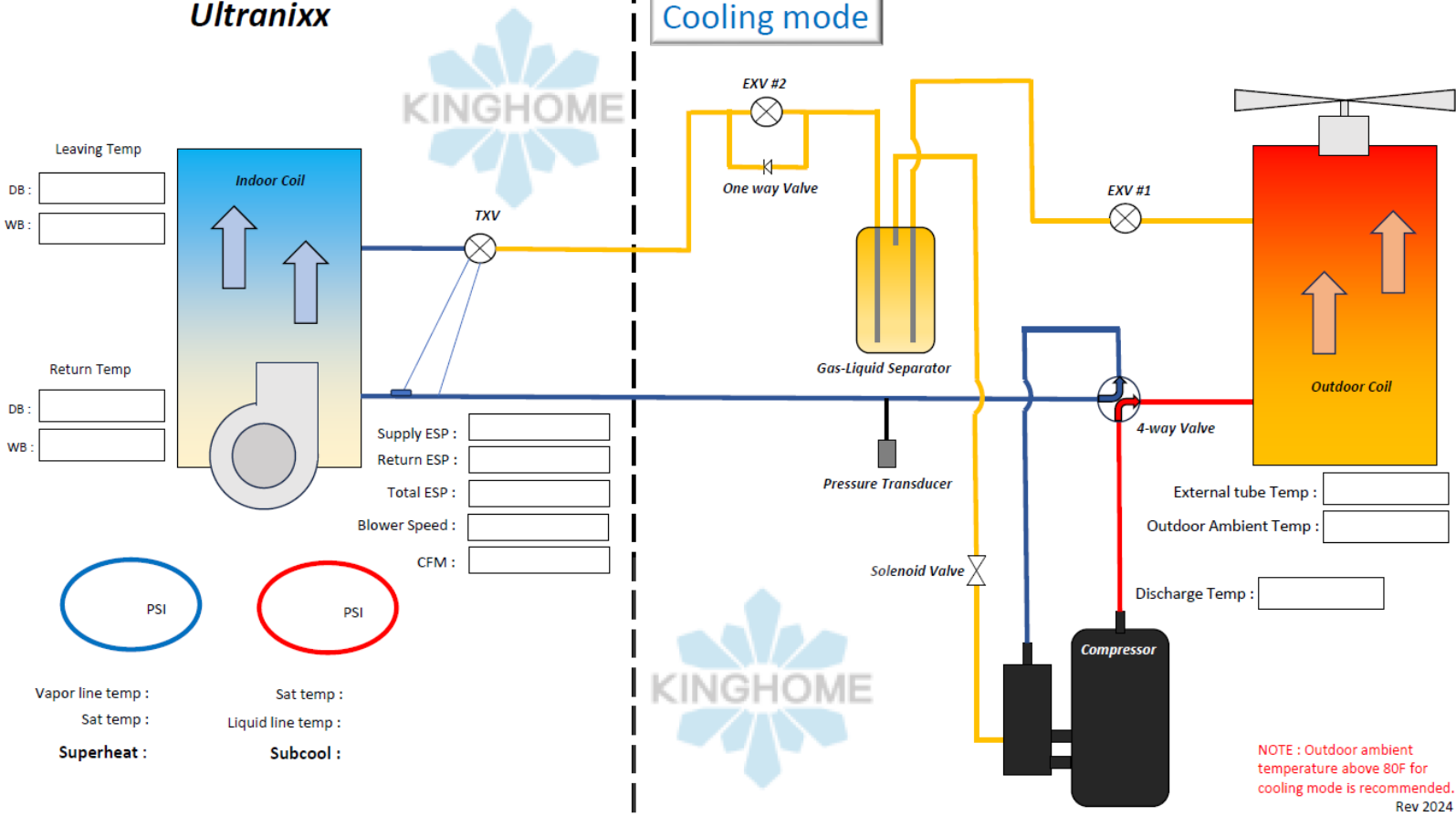

Ultrnixx

Heating mode

