



SPLIT TYPE

PULAR

Model:
KW18HQ25SDI
KW18HQ25SDO

#AHRI : 211151018



Item	Unit	Specification
ODU Model	-	KW18HQ25SDO
IDU Model	-	KW18HQ25SDI
System Ratings		
Cooling Capacity	Btu/h	18000
Heating Capacity (47°F)	Btu/h	18000
Heating Capacity (17°F)	Btu/h	10800
Cooling Capacity Range	Btu/h	5118~21154
Heating Capacity Range	Btu/h	4436~21154
Cooling Power Input (Max)	W	2300
Heating Power Input (Max)	W	2350
SEER2	-	23.0
HSPF2	-	8.5
EER	W/W	3.66
COP	W/W	3.42
Cooling Operation Range	°F (°C)	-20~122(-29~50)
Heating Operation Range	°F (°C)	-22~86(-30~30)
Gas Pipe Size (OD)	Inch (MM)	5/8 (16)
Liquid Pipe Size (OD)	Inch(MM)	1/4 (6)
Connection Method	-	Flared
Factory Charge	oz	54.7
Additional Charge	oz/ft	0.5
Pre-Charge Length	ft.	25
MAX Refrigerant Length	ft.	82
Min Refrigerant Pipe Length	ft.	10
MAX Refrigerant Pipe Elevation	ft.	33
Indoor Unit Data		
Fan Motor Power Output	W	45
Fan Motor FLA	A	0.4
Air Flow Volume	CFM	282/506
Sound Pressure Level	dB(A)	32/58
Dehumidification	pt/hr	3.80
Power Supply	-	230V / 1Ph / 60Hz
Min/Max Voltage	V	187~253
MCA	A	-
MOCP/Breaker Size	A	-
Outdoor Unit Data		
Compressor Type	-	DC Inverter Rotary
Compressor RLA	A	9.6
Refrigerant Type	-	R410A
Fan Motor Power Output	W	60
Fan Motor FLA	A	1.35
Sound Pressure Level	dB(A)	58
Power Supply	-	230V / 1Ph / 60Hz
Min/Max Voltage	V	187~253
Main Supply Wire Size	-	14AWG
MCA	A	15.0
MOCP/Breaker Size	A	20.0

Job Name:

Schedule Reference:

Date:

Specification are subject to change without notice.



Outline and Physical Dimension of KW18HQ25SD

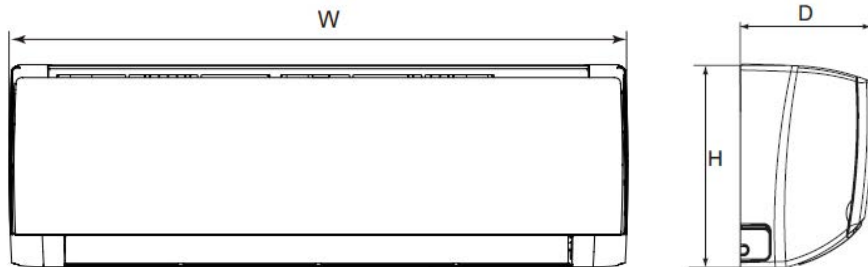

Dimensions	
W	38 12/64 (970)
H	11 52/64 (300)
D	8 52/64 (224)

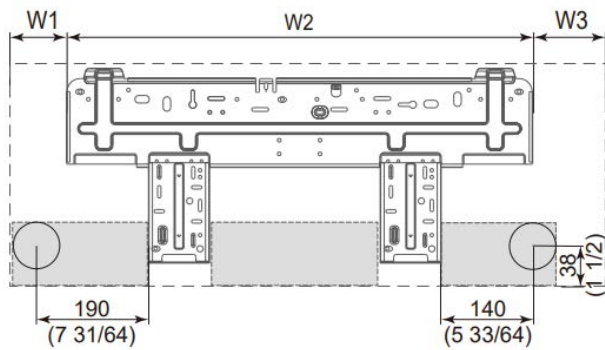

Liquid Line Valve	1/4-in OD Flared
Gas Line Valve	5/8-in OD Flared
Drain Connector	5/8-in OD

Units: inch (MM)

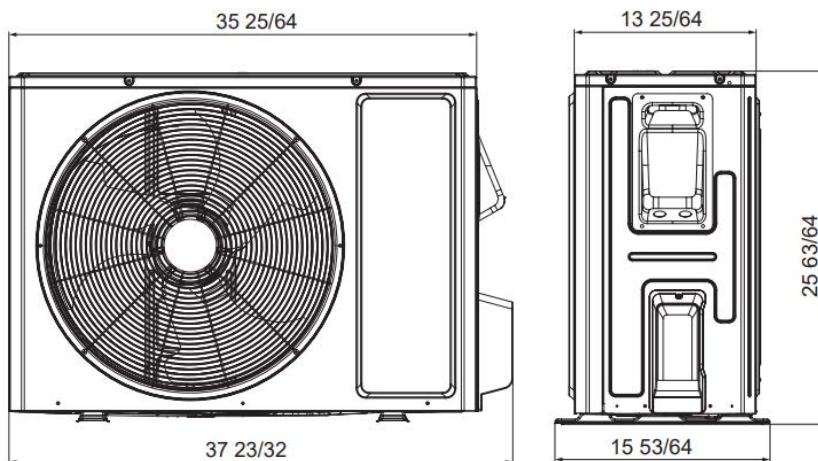

Dimensions	
W	37 23/32 (958)
H	25 63/64 (660)
D	15 53/64 (402)

Units: inch (MM)

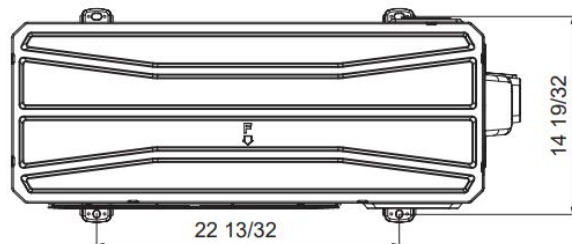

Liquid Line Valve	1/4-in OD Flared
Gas Line Valve	5/8-in OD Flared

Net Weight IDU	28.7 lb (13,5KG)
Gross Weight IDU	35.3 lb (16KG)
Net Weight ODU	95.9 lb (43,5KG)
Gross Weight ODU	105.8 lb (48KG)

