

MADE IN CHINA



SERVICE MANUAL

KRSCQ16HGD



# Contents

<b>Product Data</b> .....	<b>1</b>
<b>1 Product Data</b> .....	<b>1</b>
1.1 Lineup .....	1
1.2 Nomenclature.....	1
1.3 Product Features .....	1
1.4 Operating Principle .....	4
1.5 Technical Data .....	5
<b>2 Exploded Views and Part Lists</b> .....	<b>9</b>
<b>3 Supply Scope</b> .....	<b>11</b>
<b>Model Selection</b> .....	<b>12</b>
<b>1 Model Selection</b> .....	<b>12</b>
1.1 Specification of Power Supply .....	12
1.2 Flowchart of Model Selection.....	12
1.3 Design Principle .....	12
<b>2 Selection of the Underfloor Coils</b> .....	<b>12</b>
2.1 Calculation of Unit Load for Floor Heating.....	12
2.2 Selection of Tube Spacing of the Underfloor Coils .....	13
2.3 Selection of Loop Quantity of Coils for Each Room.....	13
<b>3 Quantity and Location of the Water Manifolds</b> .....	<b>14</b>
3.1 Design Requirements on Loop Quantity for Circulation Water .....	14
3.2 Requirements on Installation of the Water Manifold .....	15
<b>4 Section of FCU</b> .....	<b>16</b>
4.1 FCU Type Selection .....	16
4.2 Matching of Capacity .....	16
<b>5 Examples for Model Selection</b> .....	<b>16</b>
5.1 General Introduction to the Example Project .....	16
5.2 Heat Load Calculation.....	16
<b>Control</b> .....	<b>18</b>
<b>1 Integral Control Concept</b> .....	<b>18</b>
1.1 Control Principle Diagram .....	18
1.2 Control Flowchart.....	21
<b>2 Main Control Logics</b> .....	<b>21</b>
2.1 Cooling.....	21
2.2 Heating.....	22

2.3 Water Heating .....	22
2.4 Shutdown .....	23
2.5 Control to the Compressor .....	23
2.6 Control to the Fan .....	23
2.7 Control to the 4-way Valve .....	23
2.8 Control to the Water Pump .....	23
2.9 Control the Electronic Expansion Valve .....	23
2.10 Protection Control .....	24
<b>3 General .....</b>	<b>25</b>
3.1 Home Page .....	25
3.2 Menu Page .....	26
3.3 Backlight .....	27
<b>4 Operation Instructions .....</b>	<b>27</b>
4.1 ON/OFF .....	27
4.2 Function Setting .....	28
4.3 User Parameter Setting .....	37
4.4 Commissioning Parameter Setting .....	39
4.5 Viewing .....	49
4.6 General Setting .....	53
<b>5 Intelligent Control .....</b>	<b>55</b>
5.1 Install GREE+ APP .....	56
5.2 Setting of Other Functions .....	61
<b>UNIT INSTALLATION .....</b>	<b>63</b>
<b>1 Installation Guides .....</b>	<b>63</b>
<b>2 Field Supplied Pipes and Valves .....</b>	<b>67</b>
<b>3 Service Tools .....</b>	<b>68</b>
<b>4 Installation Instructions .....</b>	<b>69</b>
4.1 Installation Examples .....	69
4.2 Pre-Installation .....	70
4.3 Selection of Installation Location .....	71
4.4 Outline dimension of outdoor unit .....	71
4.5 Installation of Monobolc Unit .....	72
4.6 Installation of Hydraulic Unit .....	73
4.7 Requirements on water quality .....	75
4.8 Wiring of the Terminal Board .....	76
4.9 Wiring of the 2-Way Valve .....	76

4.10 Wiring of Other Thermal.....	77
4.11 Wiring of Optional Electric Heater .....	78
4.12 Wiring of the Gate-Controller .....	79
4.13 Wiring of the Remote Air Temperature Sensor .....	80
4.14 Wiring of the Thermostat.....	81
<b>5 Commissioning and Test Run.....</b>	<b>82</b>
5.1 Check before startup.....	82
5.2 Trial run.....	83
<b>TEST OPERATION &amp; TROUBLESHOOTING &amp; MAINTENANCE.....</b>	<b>84</b>
<b>1 Precheck.....</b>	<b>84</b>
1.1 Check for Wiring .....	84
1.2 Check for the Water System .....	84
1.3 Check for the Communication System.....	84
1.4 Trial Run.....	84
<b>2 Error Code List .....</b>	<b>84</b>
<b>3 Flow Chart of Troubleshooting .....</b>	<b>90</b>
<b>4 Troubleshooting for the Drive Board.....</b>	<b>93</b>
4.1 Diagnosis of the driving board .....	93
4.2 Diagnosis flowchart of the driving board .....	94
<b>5 Disassembly of the Unit.....</b>	<b>101</b>
<b>6 Daily Maintenance and Repair.....</b>	<b>104</b>
6.1 Daily Maintenance .....	104
6.2 Notice before seasonal use .....	105
6.3 Repair .....	105



## Product Data

### 1 Product Data

#### 1.1 Lineup

Series	Model	Product Code	Cooling Capacity (kW)	Heating Capacity (kW)	Power Supply	Refrigerant	Image
KINGHOME MONOBLOC	KRSCQ16HGD	ER01002540	12.5	15.0	208/230VAC,1Ph,60HZ	R32	

#### 1.2 Nomenclature

G	RS	-	C	Q	16	Pd	/	Nh	G3	-	D
1	2		3	4	5	6		7	8		9

NO.	Description	Options
1	GREE	G-GREE Air to water heat pump
2	Heat Pump Water Heater	RS
3	Heating Mode	S= Static; C=Circulating
4	Function	Q=Multi-function; Omitted=Single-function
5	Nominal Heating Capacity	16=16kW
6	Compressor Type	Pd=DC Inverter; Default=On/Off
7	Refrigerant	Nh=R32
8	Design Serial Number	G3,G4, G4 series is the same with G3 series but without the electric heater.
9	Power Supply	D=208/230V, ~, 60Hz

#### 1.3 Product Features

##### 1.3.1 General

It's a kind of integrated DC inverter unit that can provide cooling, heating and water heating functions, and can reach an energy efficiency of COP up to 4.4. It adopts R32 refrigerant and dual-stage compressor. For heating, ambient temperature range is -25~35°C while the leaving water temperature range is 25~65°C.

The Versati III unit is designed specially for the North America market where there is a demand for high-temperature water. Thanks to the dual-stage compression and enthalpy gain through gas injection, the heating energy efficiency at low temperature will rise up greatly with the leaving water temperature up to 60°C. The units can realize space heating and sanitary hot water supply through terminal units, like the fan coil unit, floor coil and radiator. Environment-friendly refrigerant R32 is adopted for the unit, with ODP of 0 and quite low GWP (=675). Besides, the adopted heat pump technologies will reduce consumption of coal and other energy source and lower greatly CO<sub>2</sub> emission. It is widely applicable to small and medium-sized apartment, large-sized villa etc.

### 1.3.2 Features

◆ Wide Operation Range

Heating: -25~35°C; Cooling: -15~48°C; Water Heating: -25~45°C

◆ Unique Low Ambient Dual-stage Compressor

- (1) Under low-temperature conditions, compared with the conventional compressor, the dual-stage low ambient dual-stage compressor will generate less loss of heat capacity and get higher energy efficiency.
- (2) Floodback, high discharge temperature and other problems can be completely avoided under low-temp conditions and the compressor's reliability will be enhanced greatly.
- (3) Dual-stage compression, dual-stage throttling and enhanced vapor injection will raise the leaving water temperature and improve the control accuracy.
- (4) Resistance to compressor status:  
16kW—UV/VW/UW:0.79±7%Ω

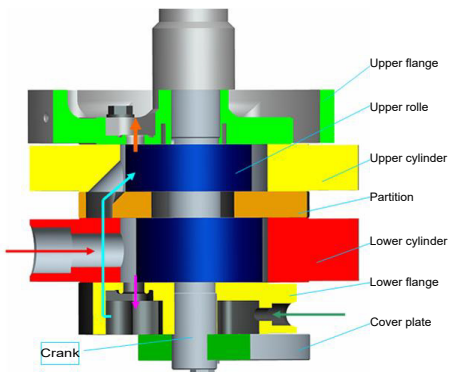

◆ High-efficiency Component(Inverter pump, Inverter fan, Plate heat exchanger)

- (1) The DC inverter fan can control the air volume accurately and make the system run more stably and save more energy.
- (2) The high-efficiency plate heat exchanger will improve the unit's performance largely.



- (3) The high-efficiency water pump will also improve the unit's performance largely.



◆ Brand-new Controller

- (1) White appearance, exquisite design, and the wall-mounted design that facilitates installation.
- (2) Liquid crystal display and touch-screen operation.
- (3) The 12V JACK interface can supply power to the control separately and lengthen the communication distance.
- (4) The remote monitoring interface can monitor the unit through the Modbus interface and be integrated into the BMS system.



◆ Smart Control, Powerful Function

- (1) The operating mode can be switched freely. Furthermore, based on different demands, the holiday mode, weather-dependent mode, quiet timer, temperature timer and floor commissioning can activated.
- (2) Multiple protections can make this product much safer. The added electric heater will prevent the plate heat exchanger from being frosted owing to too low water temperature and resultantly extend the service life of the product and enhance its safety and reliability.
- (3) The newly developed smart defrosting control program, can intelligently defrost when it is actually needed and thus ensure a sustainable heat supply for users.

The flowchart with parameters to be set.

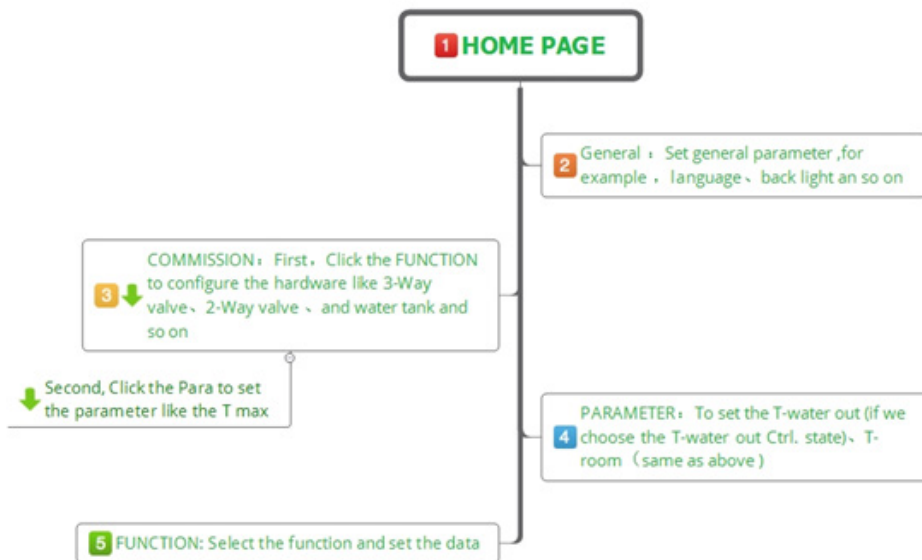

## 1.4 Operating Principle

### 1.4.1 Schematic Diagram

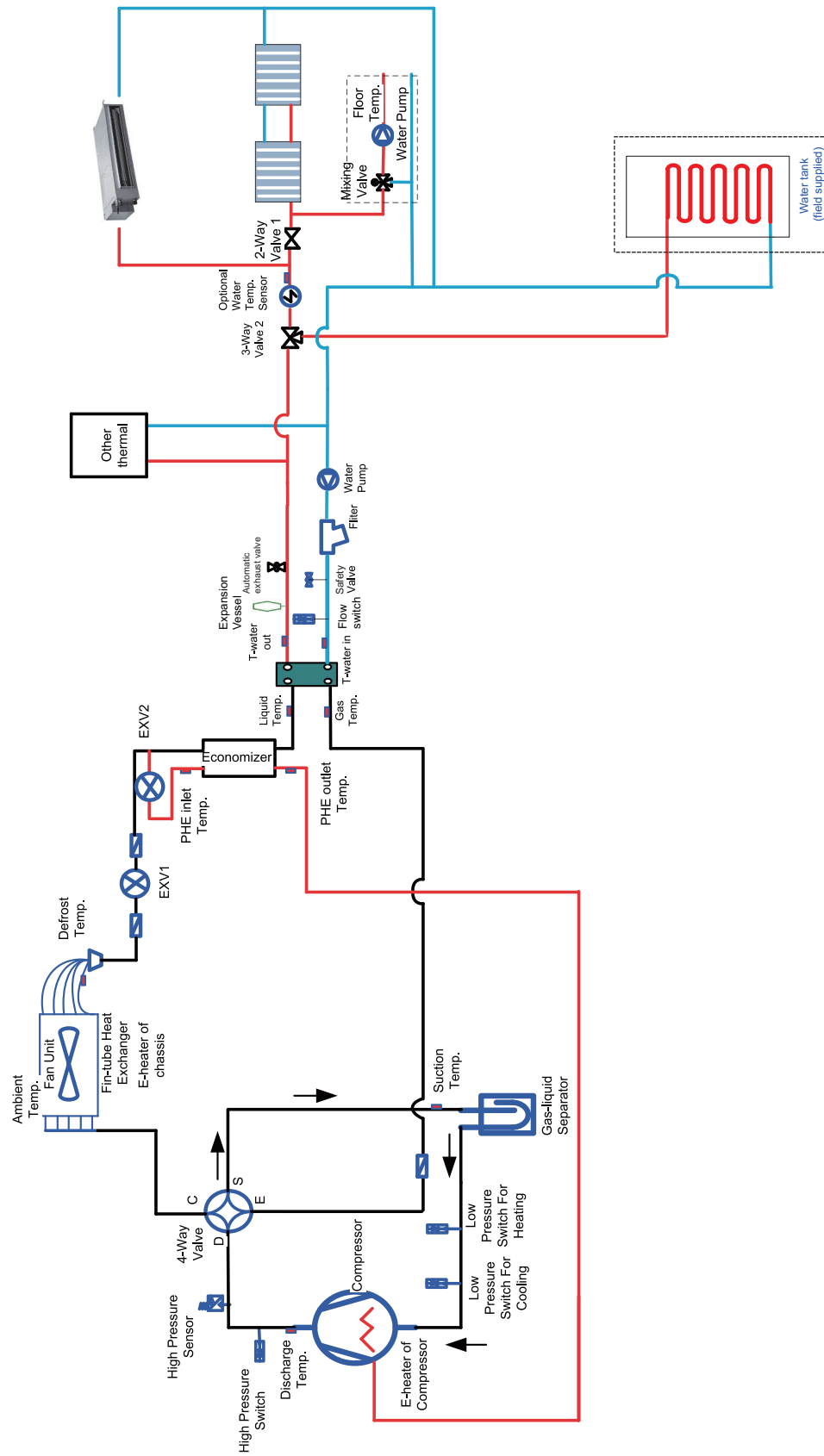

## 1.5 Technical Data

### 1.5.1 Parameter List

Model		KRSCQ16HGD
Max Heating Capacity*	BTU/h	61000
Min Heating Capacity*	BTU/h	23204
Max Cooling Capacity**	BTU/h	46000
Min Cooling Capacity**	BTU/h	17915
nominal Heating Capacity	BTU/h	51186
nominal Cooling Capacity	BTU/h	42655
COP*		UP to 4.4
EER**		UP to 11.8
Max Running Amps	A	60
Compressor Rating Load	A	28
Electric Heater Minimum Circuit Ampacity	A	32
Whole Unit Max Fuser Or Circuit Breaker	A	60
Electric Heater Max Fuser Or Circuit Breaker	A	35
Power Supply		208/230/1N-60HZ
Compressor Quantity		1
Compressor Model		2-stage Inverter Compressor
Fan Quantity		1
Rated input current of fan motor		1.7A
Fan Rotate Speed	RPM	100~800
Sound Power Level***	dB(A)	59
Space Heating: Operation Temp Range		-13 to 95°F (-25 to 35°C)
Space Cooling: Operation Temp Range		5 to 118°F (-15 to 48°C)
Water Connection	in.	1 1/3
Water Flow Voume	GPM	8.65
Unit Net Dimension	in(L/W/H)	47 1/2*17 1/2*34 4/7
Unit Shipping Dimension	in(L/W/H)	52 2/3*21 7/9*40 1/6
Net Weight	lb.	328
Shipping Weight	lb.	357
Heating Test Condition:* Amb 47°F/8.3°C,LWT:105°F/40.6°C		
Cooling Test Condition:** Amb 95°F/35°C,EWT 54°F/12.2°C, LWT:44°F/6.7°C		
Sound Test Condition:***Amb95°F/35°C,EWT 53.6°F/12°C, LWT:44.6°F/7°C		

### 1.5.2 Operation Range

Item	Water Side	Heat Source/User Side
	Leaving Water Temperature (°C)	Environment Dry Bulb Temperature (°C)
Cooling	5~25	-15~48
Heating	20~65	-25~35
Water Heating	40~80 (Water Tank Temperature)	-25~45

#### Notes

- (a) When operating conditions are out of the range listed above, please contact GREE.
- (b) The leaving water temperature varies at different environment. 65°C is the highest leaving water temperature at 10-20°C ambient temperature.

(c) When the electric heater for the water tank prepared by the user themselves has been activated, the leaving water temperature can go up to 80°C.

**1.5.3 Temperature sensor parameter**

Displayed Name	Inspection range(°C)	Nominal working datas			Remark
		Cooling	Heating	Hot water	
T-outdoor	-30~150	8~50	-27~37	-27~45	temperature sensor resistance 15K
T-suction	-30~150	5~30	-25~20	-25~30	temperature sensor resistance 20K
T-discharge	-30~150	30~102	35~102	35~102	temperature sensor resistance 50K
T-defrost	-30~150	20~57	-25~30	-25~40	temperature sensor resistance 20K
T-water in PE	-30~150	10~30	20~55	20~55	temperature sensor resistance 20K
T-water out PE	-30~150	5~25	25~60	25~60	temperature sensor resistance 20K
T-optional water Sen.	-30~150	5~25	25~60	25~60	temperature sensor resistance 50K
T-tank ctrl.	-30~150	/	/	10~80	temperature sensor resistance 50K
T-floor debug	-30~150	/	25~45	/	/
Debug time	-30~150	/	12~72	/	/
T-liquid pipe	-30~150	5~25	20~57	20~57	temperature sensor resistance 20K
T-gas pipe	-30~150	30~102	35~102	35~102	temperature sensor resistance 20K
T-economizer in	-30~150	no EVI under cooling	-20~55	-20~55	temperature sensor resistance 20K
T-economizer out	-30~150	no EVI under cooling	-20~55	-20~55	temperature sensor resistance 20K
T-remote room	-30~150	18~30	18~30	18~30	/
Dis. Pressure	-40~70	25~60	25~62	25~62	/
T-weather depend	-30~150	7~25	25~60	/	based on calculation

**1.5.4 Electric Data**

Power cable specifications and air switch types in the following list are recommended.

Model	Power Supply	Power Supply Air	Air Break Switch	Minimum Section	Minimum Section	Minimum Section	Minimum Section
		Break Switch	Electric Heater	Area of Earth Wire	Area of Earth Wire (Electric Heater)	Area of Power Wire	Area of Power Wire (Electric Heater)
	V,Ph, HZ	A	A	mm <sup>2</sup>	mm <sup>2</sup>	mm <sup>2</sup>	mm <sup>2</sup>
GRS-CQ16Pd/ NhG3-D	208/230VAC, 1Ph, 60Hz	60	35	AWG8	AWG8	2*AWG8	2*AWG8

**Notes**

- (a) Additional installation is necessary for the air switch. If circuit breakers with leakage protection are in use, action response time must be less than 0.1 second, and leakage circuit must be 30mA.
- (b) The above selected power cable diameters are determined based on assumption of distance from the distribution cabinet to the unit less than 75m. If cables are laid out in a distance of 75m to 150m, diameter of power cable must be increased to a further grade.
- (c) The power supply must be of rated voltage of the unit and special electrical line for air-conditioning.
- (d) All electrical installation shall be carried out by professional technicians in accordance with the local laws and regulations.
- (e) Ensure safe grounding and the grounding wire shall be connected with the special grounding equipment of the building and must be installed by professional technicians.

(f) The specifications of the breaker and power cable listed in the table above are determined based on the maximum power (maximum amps) of the unit.

(g) The specifications of the power cable listed in the table above are applied to the conduit-guarded multi-wire copper cable (like, YJV XLPE insulated power cable) used at 40°C and resistible to 90°C (see IEC 60364-5-52). If the working condition changes, they should be modified according to the related national standard.

(h) The specifications of the breaker listed in the table above are based on the working temperature of 40°C. If the working condition changes, they should be modified according to the related national standard.

**1.5.5 Capacity Correction**

◆ Cooling Capacity Correction

Actual cooling capacity = nominal cooling capacity x cooling capacity correction coefficient.

Actual EER = nominal EER x EER correction coefficient.

Leaving Water Temp.(°F)	Capacity level	Ambient Temp.(°F)														
		86			95			104			113			118		
		Capacity*	Watts	EER	Capacity	Watts	EER	Capacity	Watts	EER	Capacity	Watts	EER	Capacity	Watts	EER
45	Max	48043	4858	9.89	46644	5424	8.60	35159	4180	8.41	22930	3088	7.43	21019	3484	6.03
	Norm	47376	4734	10.01	46000	5286	8.70	30764	3322	9.26	18917	2341	8.08	17340	2641	6.57
	Min	19330	1314	14.72	18767	1467	12.80	17265	1626	10.62	15764	1925	8.19	14450	2172	6.65
59	Max	60342	4780	12.62	58585	5337	10.98	44159	4113	10.74	28800	3038	9.48	26400	3428	7.70
	Norm	59504	4658	12.77	57771	5201	11.11	38639	3268	11.82	23760	2303	10.31	21780	2599	8.38
	Min	24278	1292	18.78	23571	1443	16.33	21685	1599	13.56	19800	1894	10.45	18150	2137	8.49
65	Max	64666	4738	13.65	62783	5291	11.87	47324	4077	11.61	30863	3012	10.25	28291	3398	8.33
	Norm	63767	4618	13.81	52888	3596	14.71	41408	3240	12.78	25462	2283	11.15	23340	2576	9.06
	Min	26018	1281	20.31	25260	1430	17.66	23239	1586	14.66	21218	1877	11.30	19450	2118	9.18

◆ Heating Capacity Correction

Actual cooling capacity = nominal cooling capacity x cooling capacity correction coefficient.

Actual COP = nominal COP x COP correction coefficient.

Leaving Water Temp.(°F)	Capacity level	Ambient Temp.(°F)											
		5			14			19			28		
		Capacity*	Watts	COP	Capacity	Watts	COP	Capacity	Watts	COP	Capacity	Watts	COP
95	Max	33536	18226	1.84	36585	16937	2.16	40243	16768	2.40	45121	16468	2.74
	Norm	28150	13450	2.09	30709	12499	2.46	33780	12374	2.73	37875	12152	3.12
	Min	12198	5200	2.35	13307	4832	2.75	14638	4784	3.06	16412	4698	3.49
113	Max	33536	22783	1.47	36585	21172	1.73	40243	20960	1.92	45121	20585	2.19
	Norm	28150	16812	1.67	30709	15623	1.97	33780	15467	2.18	37875	15190	2.49
	Min	12198	6500	1.88	13307	6040	2.20	14638	5980	2.45	16412	5872	2.79
131	Max	32926	28404	1.16	35975	26437	1.36	39634	26213	1.51	44512	25786	1.73
	Norm	27638	20961	1.32	30197	19509	1.55	33268	19343	1.72	37363	19028	1.96
	Min	11977	8103	1.48	13086	7542	1.74	14416	7478	1.93	16191	7356	2.20

KINGHOME Monobloc Type Air-to-water Heat Pump

Leaving Water Temp. (°F)	Capacity level									
		36			45			50		
		Capacity	Watts	COP	Capacity	Watts	COP	Capacity	Watts	COP
95	Max	48780	16046	3.04	61009	15252	4.00	62804	15318	4.10
	Norm	40946	11841	3.46	51182	11249	4.55	52718	11304	4.66
	Min	17743	4578	3.88	22179	4349	5.10	22844	4370	5.23
113	Max	48780	20058	2.43	61009	19065	3.20	62804	19148	3.28
	Norm	40946	14801	2.77	55277	15186	3.64	52718	14130	3.73
	Min	17743	5722	3.10	22179	5436	4.08	22844	5463	4.18
131	Max	48170	25152	1.92	60365	23954	2.52	62194	24078	2.58
	Norm	40434	18560	2.18	52547	18120	2.90	52206	17768	2.94
	Min	17521	7175	2.44	21957	6834	3.21	22622	6869	3.29



## 2 Exploded Views and Part Lists

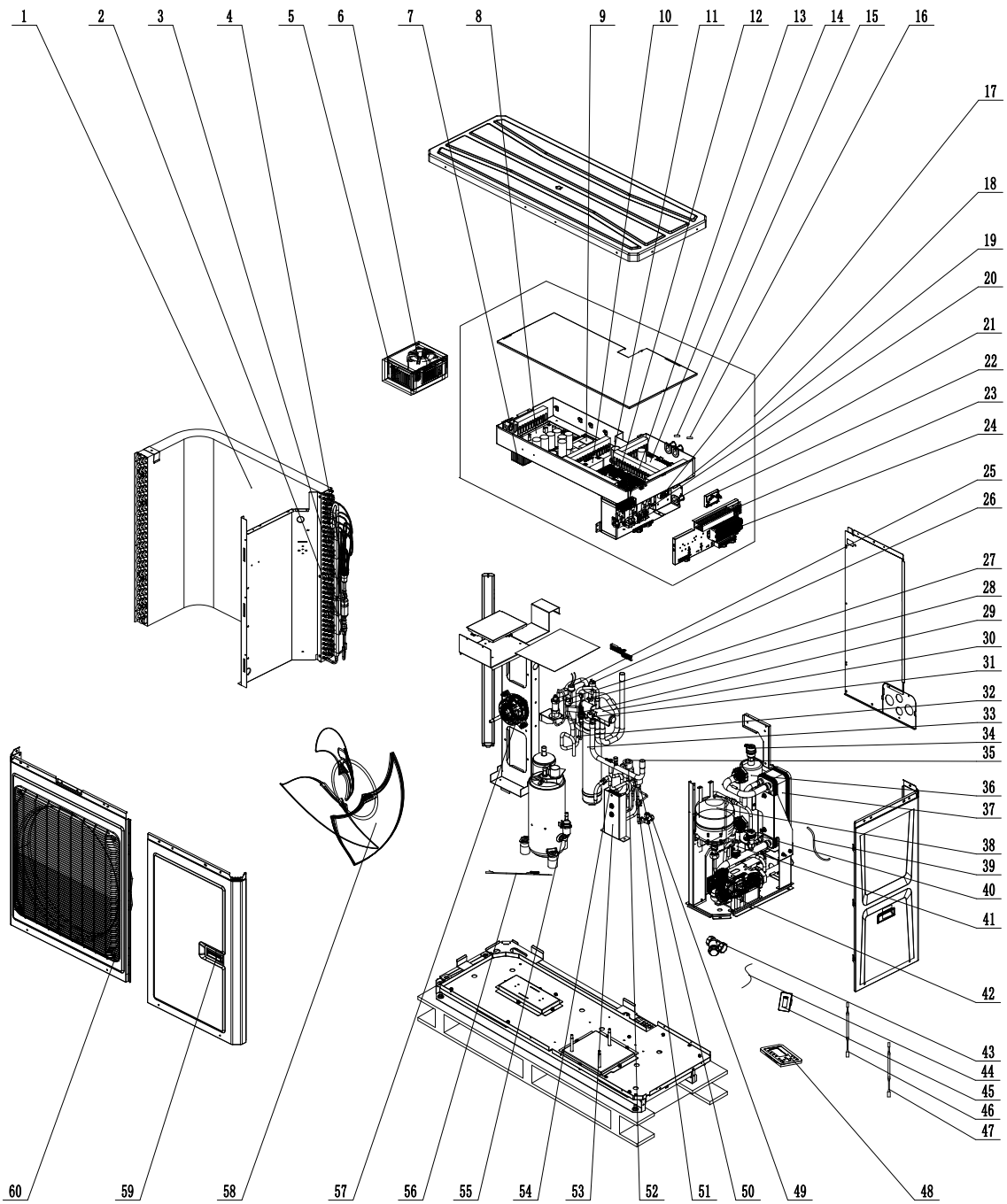

No.	Name	Quantity
1	Condenser Assy	1
2	Strainer	2
3	Silencer	1
4	Current Divider	1
5	Inductance Box Sub-assy	1
6	PFC Inductance	1
7	Radiator	1
8	Drive Board	1
9	Filter Board	1
10	Filter	1
11	mounting card(main board)	1

KINGHOME Monobloc Type Air-to-water Heat Pump

No.	Name	Quantity
12	Main Board	1
13	Bipolar AC Contactor	3
14	Main Board	1
15	Jumper	1
16	Jumper	1
17	Terminal Board	1
18	Electric Box Assy	1
19	Thermostat	2
20	Terminal Board	1
21	Terminal Board	1
22	Electrical Retaining Plate	1
23	Communication Interface Board	1
24	Terminal Board	1
25	Pressure Protect Switch	1
26	Pressure Protect Switch	1
27	Relief Valve	1
28	Pressure Protect Switch	1
29	Pressure Sensor	1
30	4-Way Valve	1
31	Magnet Coil	1
32	Nozzle for Adding Freon	1
33	Gas-liquid Separator	1
34	Auto Air Outlet Valve	1
35	Electronic Expansion Valve Fitting	1
36	Electric Heater	1
37	Plate-type Heat Exchanger	1
38	Expansion Drum	1
39	Drainage Pipe Sub-assy	1
40	Relief Valve	1
41	Steam current Switch	1
42	Water Pump	1
43	Strainer	1
44	Signal Wire	1
45	Remote room temperature sensor	1
46	Temperature Sensor	1
47	Temperature Sensor	1
48	Display Board	1
49	Cut-off valve 1/4(N)	1
50	Electronic Expansion Valve	1
51	Electronic Expansion Valve Fitting	1
52	Electronic Expansion Valve	1
53	Economizer	1
54	Nozzle for Adding Freon	1
55	Compressor and Fittings	1
56	Electrical Heater(Compressor)	1
57	Brushless DC Motor	1
58	Axial Flow Fan	1
59	Handle	2
60	Front Grill	1

### 3 Supply Scope

S= Standard O= Optional F= Field Supplied

Name	Standard	Optional	Field Supplied	Standard Part Code
Owner's Manual for the Main Unit	√	/	/	600005066597
Owner's Manual for the Control	√	/	/	600005067234 600005067233
2-way Valve	/	/	√	/
3-way Valve	/	/	√	/
Remote Temperature Sensor	√	/	/	30261014
Wired Controller	√	/	/	/
Communication Cable	√	/	/	4003004107
Water Tank Temperature Sensor	√	/	/	3900028316G
Expansion Bolt	√	/	/	70110066
Other Thermal	/	/	√	/
Optional Electric Heater	/	/	√	/

## Model Selection

### 1 Model Selection

#### 1.1 Specification of Power Supply

Model	Power Supply
	V,Ph,Hz
GRS-CQ16Pd/NhG3-D	208/230VAC, 1Ph, 60HZ

#### 1.2 Flowchart of Model Selection

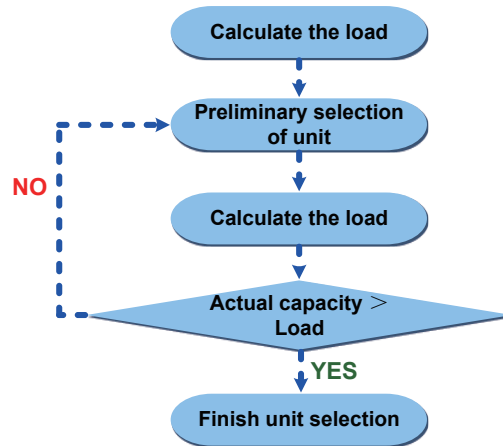

#### 1.3 Design Principle

- (1) Cooling: capacity of the unit  $\geq$  cooling load of the air conditioning
- (2) Heating: capacity of the unit  $\geq \max\{\text{heating load, floor heating load, water heating load}\}$
- (3) Water Tank: it should be selected based on the sanitary outfit or quantity of users. Each unit can accommodate only one water tank.

## 2 Selection of the Underfloor Coils

### 2.1 Calculation of Unit Load for Floor Heating

**Empirical Values of Floor Heating Load Per Square Meter**

House W/m <sup>2</sup>	
Dining Room	100~120
Mater Room	100~110
Guest Room	110~130
Study Room	90~110
Villa W/m <sup>2</sup>	
Dining Room	110~140
Mater Room	100~120
Guest Room	100~130
Study Room	100~120

#### Notes

- (a) Villas of which the load is generally larger than that of the houses should take the value between the middle and the maximum empirical values listed above.
- (b) The top layer of which the load is generally larger than the middle or bottom layer should take the maximum empirical value.
- (c) The guest room of which the load is generally much larger should take the value between the intermediate and the maximum empirical values listed above.

(d) For those of which the external walls or glass areas are large, it is recommended to take the load calculation.

(e) The heating load for the bathroom is generally 500W/room.

## 2.2 Selection of Tube Spacing of the Underfloor Coils

Tube spacing of the underfloor coils which will directly affect heat dissipation of the floor depending on the tube material, indoor design temperature, supply water temperature and floor material.

### Heat Dissipation of Commonly Used Coils

(Tube material: PE-X, Indoor temperature:18°C, Average water temperature:45°C)

Floor Material	Thermal Resistance m <sup>2</sup> ·K/W	Tube Spacing mm	Heat Dissipation W/m <sup>2</sup>	Tube Spacing mm	Heat Dissipation W/m <sup>2</sup>
Stone	0.02	200	147.0	150	159.8
Wood	0.075	200	111.2	150	117.8

The dissipated heat of the floor coil is larger than the load for the floor heating system; however the deviation cannot be larger than 10%.

## 2.3 Selection of Loop Quantity of Coils for Each Room

### 2.3.1 Type of Underfloor Coils

When selecting underfloor coils, we should consider both their comfortability and heating capacity. The most commonly used coils are shown as below.

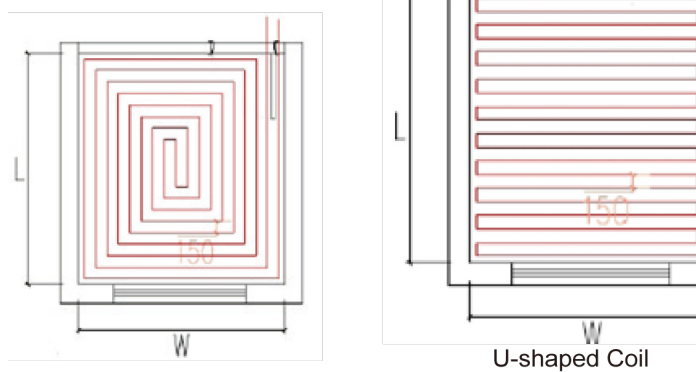

Square-shaped Coil (Recommended) U-shaped Coil

Length of coils is calculated as below:

Square-shaped coil:  $=L \cdot W / \text{tube spacing} = \text{area} / \text{tube spacing}$

U-shaped coil:  $=L - 1 + L \cdot W / \text{tube spacing} = L - 1 + \text{area} / \text{tube spacing}$

The reason why the square-shaped coils are recommended is because they can keep even temperature distribution. Special demand can be met by adjusting the tube spacing.

Distance from the room to the water manifold should be estimated according to the actual conditions of the project and generally should not exceed 30m.

### 2.3.2 Selection of Loop Quantity for Each Room

- (1) Length of a single loop should not exceed 100m. If so, it should be divided into multiple loops.
- (2) Area of a single loop = tube length × tube spacing = 100m × 150mm = 15m<sup>2</sup>

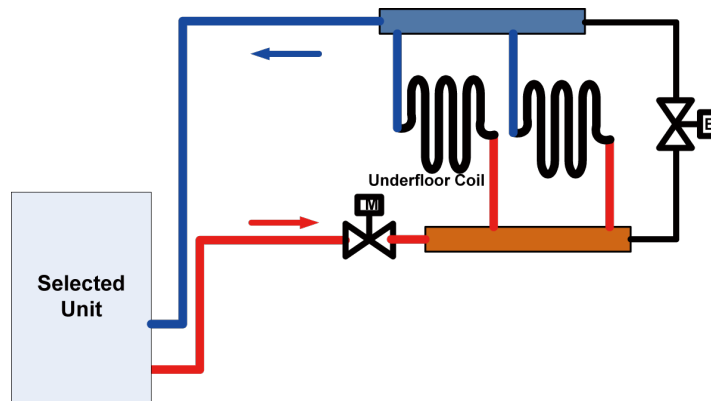

Length of underfloor coils is recommended to be within 100m and length of each branch should be kept the same to the most extent.

### 3 Quantity and Location of the Water Manifolds

The water manifold is a kind of device for distributing water for the water supply and return tubes.

#### 3.1 Design Requirements on Loop Quantity for Circulation Water

- (1) One water manifold is allowed for at most 8 loops. When quantity of loops exceeds 12, then two water manifolds should be used, or it will cause uneven water distribution.
- (2) The maximum flow rate of the water manifold should be less than 0.8m/s.
- (3) The inlet and outlet of each loop should be connected to the water manifold and the inner diameter of the water manifold should be or larger than that of the main water supply/return tube.

Calculation of loop quantity for circulation water can be done as per the formula below:

$$N=A/A1$$

N—loop quantity

A— total floor heating area (unit: m<sup>2</sup>)

A1— floor heating area per single loop (unit: m<sup>2</sup>)

Example for how to calculate the floor heating area per single loop: when the tube length is 120m, and tube spacing is 200mm, then the floor heating area per single loop is 120×0.2=24m<sup>2</sup>.

- (4) One trap (collector) cannot be used for different floors, or it would cause uneven water distribution.

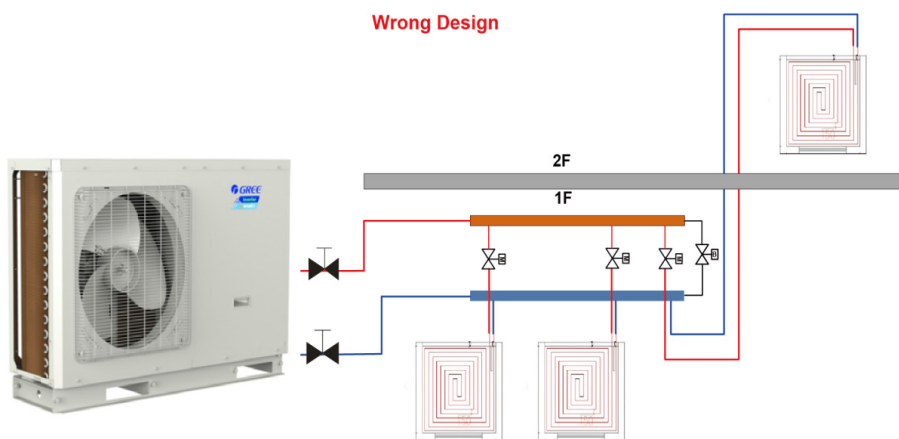

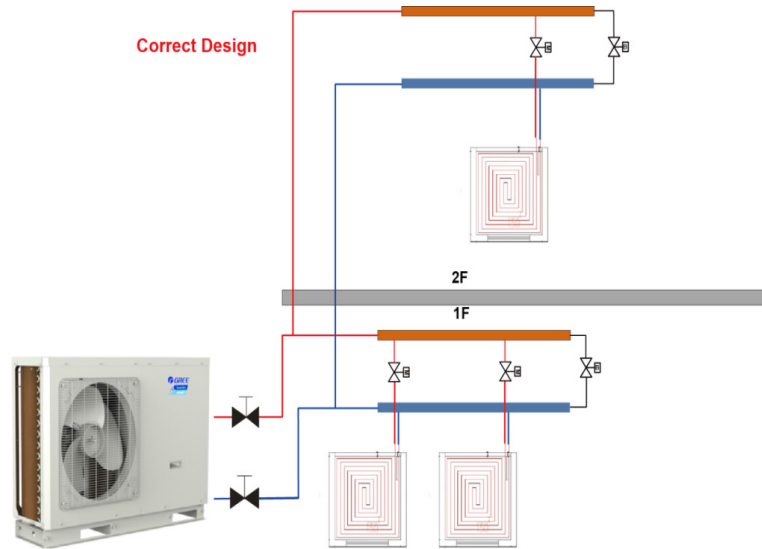

- (5) Distance between the unit and the water manifold should be within 15m. If the distance exceeds 20m, then it is required to calculate the hydraulic power.

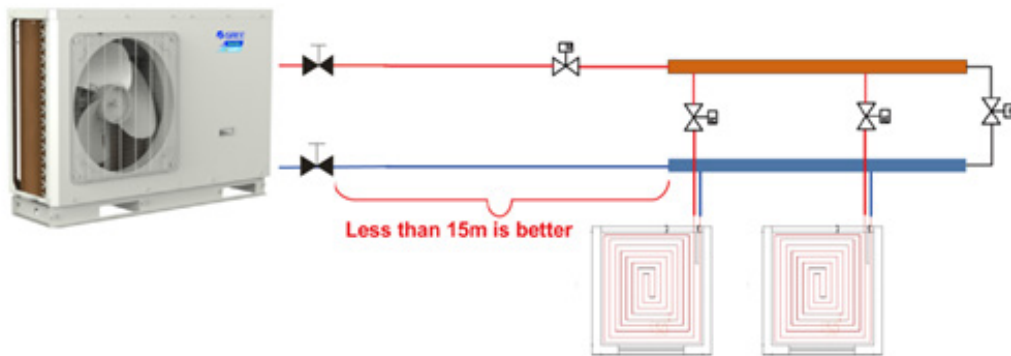

### 3.2 Requirements on Installation of the Water Manifold

- (1) The water manifold should be installed on the wall or inside the special box. For housing constructions, it is generally installed in the kitchen.
- (2) The valve for the water manifold should be installed horizontally and keep a distance of at least 300mm to the ground.
- (3) The water supply valve should be installed upstream of the water manifold and the return valve should be installed downstream of the water manifold.
- (4) A filter is required upstream of the water manifold.

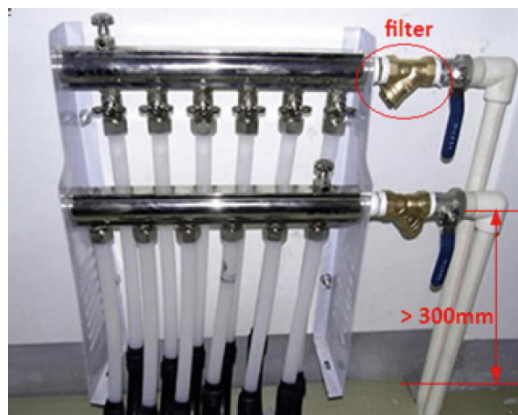

## 4 Section of FCU

### 4.1 FCU Type Selection

The air-water fan coil unit is optional for Versati units.



### 4.2 Matching of Capacity

Load of the FCU is recommended to be between 70%~120% of the Versati unit.

**Notes:**

(a) When load of the FCU is too small, the unit would start/stop frequently, which is adverse for oil return.

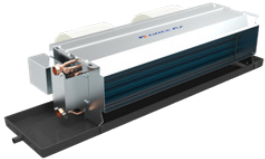
(b) When load of the FCU is too large, the unit would always run under high frequency, which may bring about energy waste.

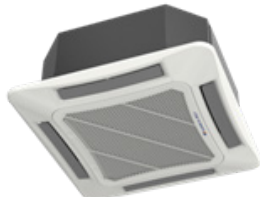
Type	Air Volume (m <sup>3</sup> /h)	Cooling Capacity (kW)	Heating Capacity (kW)	Static Pressure (Pa)	Appearance
Wall mounted type	166~1020	2.1~5.4	3.15~8.5	—	
Concealed ceiling type	213~2380	1.85~12.8	3.1~21	12, 30	
Floor ceiling type	213~2040	1.9~10.8	2.8~16.2	—	
Cassette type	480~1700	4.5~9	6.8~13.7	—	

## 5 Examples for Model Selection

### 5.1 General Introduction to the Example Project

For a two-floor house, there is a master room and a bathroom for each floor and both of them require floor heating. Other rooms use the heat pump for heating in winter. The master room covers 28m<sup>2</sup> and the bathroom covers 12m<sup>2</sup>.

### 5.2 Heat Load Calculation

#### 5.2.1 Load Calculation of a Single Floor

Room	Area	Heat Index (W/m <sup>2</sup> )	Heat Load (W)
Master Room	28	82	2296
Bathroom	12	72	900
Total Load			2296+900=3196W



**5.2.2 Arrangement Design of the Underfloor System for A Single Floor**

Assumed conditions: the floor is cement or ceramics, the normal external diameter of the heating pipe is 20mm; thickness of the stuffer is 50mm; thickness of PS foam insulation is 20mm, supply water temperature is 45°C; return water temperature is 35°C; indoor design temperature is 20°C.

$$\text{Average Temperature of the Heating Pipe}=(45+35)/2=40^{\circ}\text{C}$$

**5.2.3 Arrangement Design of the Underfloor System for the Bath Room**

Heat load of the bath room is 900W, heat dissipation per unit area is 75W/m<sup>2</sup>, tube spacing of the heat pipe is 30mm, and heat loss is 25.4 W/m<sup>2</sup>, then the total heat loss is:

$$25.4 \times 12 = 304.8\text{W}$$

Based on the heat load listed in the table above, the heating load for the bathroom is:

$$900 + 304.8 = 1204.8\text{W}$$

According to the formula  $Q=C_p G \Delta T$ , the flow rate of the heating pipe for the bathroom is:

$$G = \frac{Q}{C_p \Delta T} = \frac{1.2048\text{kJ}/1/3600\text{ h}}{4.186\text{kJ}/(\text{kg} \cdot \text{C}) \times 1000\text{kg}/\text{m}^3 \times (45-35)\text{ C}} = 0.104\text{m}^3/\text{h}$$

If the outer diameter of the heating pipe is 20mm and thickness is 2mm, then the minimum flow for the heating pipe is:

$$G = \pi/4 D^2 v = 3.14/4 \times (20-2 \times 2)^2 \times 10^{-6} \times 0.25 \times 3600 = (0.18\text{m}^3)/\text{h}$$

It can be see that the arranged piping system for the bathroom does not meet the technical requirement and need to combine the loops with the master room.

**5.2.4 Arrangement Design of the Underfloor System for the Master and Bath Rooms**

According to the calculation results, the total heat load for the master and bath rooms is 3196W, heat dissipation per unit area is 82W/m<sup>2</sup>, tube spacing of the heating pipe is 300mm, and heat loss is 25.4 W/m<sup>2</sup>, then the total heat loss is:

$$3196 + 1016 = 4212\text{W}$$

According to the formula  $Q= C_p G \Delta T$ , the flow rate is

$$G = \frac{Q}{C_p \Delta T} = \frac{4.212\text{kJ}/(1/3600\text{h})}{4.186\text{kJ}/(\text{kg} \cdot \text{C}) \times 1000\text{kg}/\text{m}^3 \times (45-35)\text{ C}} = 0.3622\text{m}^3/ > 0.18\text{m}^3/\text{h}$$

Loop quantity is 0.3622/0.18=2.012 and the round-off number is 2.

**5.2.5 Check**

A. Check for the flow rate

$$\frac{0.3622/2}{3.14 \times 0.008^2 \times 3600} = 0.2503\text{m/s}$$

Floor rate of each loop is within 0.25~0.5m/s and the system can run stably.

B. Check for the tube length

When the average tube spacing is 30mm, the required length of the heating pipe per square meter is 3.5m, length of total coils is 3.5×40=140 and length for each loop is 140/2=70.

It can be seen that the length for each loop is less than 120m and it meets the design requirement.

C. Check for the ground average temperature

$$t_p = t_n + 9.82 \times (q_x / 100) \quad 0.969 = 20 + 9.82 \times (82 / 100) \quad 0.969 = 28^{\circ}\text{C}$$

**Upper Limits and Average Floor Temperature**

Average Floor Temperature		
Area	Average Temperature	Maximum Temperature
Long-term Dwelling Area	24~26	28
Short-term Dwelling Area	28~30	32
Nobody Area	35~40	42

## Control

### 1 Integral Control Concept

#### 1.1 Control Principle Diagram

- ◆ Control diagram

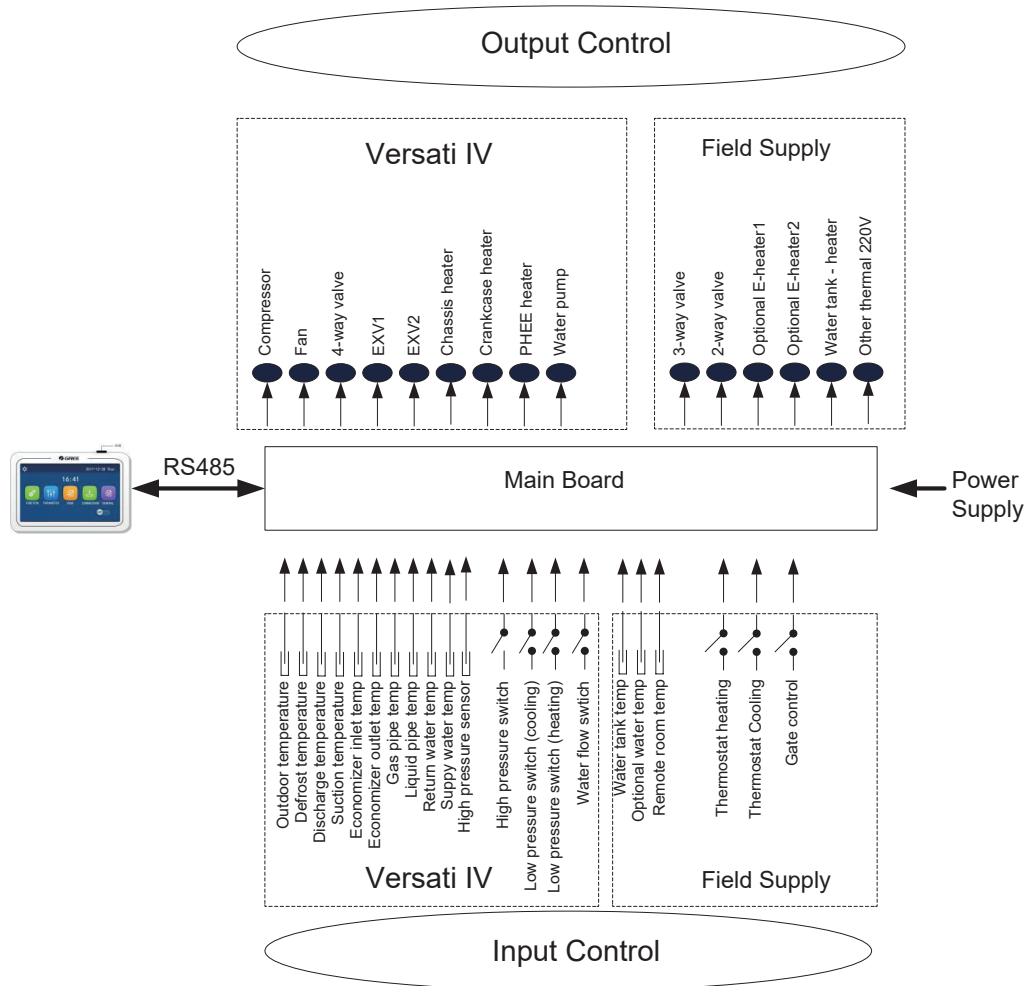

◆ Instructions for Protective Elements

- (1) The outdoor temperature is detected by the sensor installed at fins of the finned heat exchanger, which is mainly used to control the initialization steps of the fan and the electronic expansion valve and also limit the maximum running frequency of the compressor. When this sensor fails, the main board will detect it and deliver this error message to the controller and then the unit will fail to start up or shut down.
- (2) The defrost temperature is detected by the sensor installed at the defrosting pipes of the finned heat exchanger, which is mainly used to control defrosting. When this sensor fails at the heating or water heating mode, the compressor will stop and this error will be displayed at the controller. When it fails at the cooling mode, the compressor continues to run but this error will be displayed at the controller.
- (3) The discharge temperature is detected by the sensor installed at the discharge pipe of the compressor, which is mainly used for high discharge temperature protection. When this sensor fails, this error will be displayed at the controller, all loads except the water pump of the solar system and the electric heater of the water tank will stop. Then, the main unit will resume normal running when this error is eliminated.
- (4) The suction temperature is detected by the sensor installed at the suction pipe of the compressor, which is mainly used to control superheating degree. When this sensor fails, this error will be displayed at the controller, all loads except the water pump of the solar system and the electric heater of the water tank will stop. Then, the main unit will resume normal running when this error is eliminated.
- (5) The temperature sensor at the economizer is used to detect the temperature of the economizer after throttling via the electrostatic expansion 2. Under the Heating or Hot Water mode, this sensor and that at the economizer outlet both are used to control the opening angle of the electronic expansion valve 2. Under the Cooling mode, the electronic expansion valve 2 is fully closed.
- (6) The temperature sensor at the economizer outlet is used to detect the temperature of the outlet of the economizer. Under the Heating or Hot Water mode, this sensor and that at the economiser inlet both are used to control the opening angle of the electronic expansion valve 2. Under the Cooling mode, the electronic expansion valve 2 is fully closed.
- (7) The high pressure is detected by the sensor installed at the discharge pipe of the compressor, the low pressure is detected by the sensor installed at the suction pipe of the compressor, and the enhanced vapor injection pressure is detected by the sensor installed at the enhanced vapor injection pipe. The first one is mainly used for high pressure protection, the second one is mainly used to control defrosting, freeze protection and superheating degree, and all of three are used to together to control the intermediate pressure ratio of the compressor. When any of these sensors fails, it will be displayed at the controller, all loads except the water pump of the solar system and the electric heater of the water tank will stop. Among them, the water pump will stop 120 seconds later than the compressor. Then, the main unit will resume normal running when this error is eliminated.

Component	Range
High pressure sensor	4.7/3.8MPa(gauge)
Low pressure switch (cooling)	0.45/0.55MPa(gauge)
Low pressure switch (heating)	0.1/0.2 MPa(gauge)

- (8) The return water temperature of the plate heat exchanger is detected by the sensor installed at the inlet pipe of the plate heat exchanger, which is mainly used for freeze protection. When this sensor fails, this error will be displayed at the controller but the unit will resume normal operation.
- (9) The supply water temperature of the plate heat exchanger is detected by the sensor installed at the outlet pipe of the plate heat exchanger, which is mainly used for freeze protection at the water side. When this sensor fails, this error will be displayed at the controller and the unit will continues to operate.
- (10) The optional water temperature is detected by the sensor installed at the outlet pipe of the optional E-heater, which is mainly used to control the supply water temperature. When this sensor fails, this error will be displayed at the controller, all loads except the electric heater of the water tank will stop (the 2-way electric and 3-way electric valves will be closed).

- (11) The temperature sensor for the vapor line is used to detect the temperature of the vapor refrigerant line. Under the Cooling mode, it and that for the liquid line together are used to control the opening of the electronic expansion valve 1.
- (12) The temperature sensor for the liquid line is used to detect the temperature of the liquid refrigerant line. Under the Cooling mode, it and that for the vapor line together are used to control the opening angle of the electronic expansion valve 1.
- (13) The hi-pressure switch is used to judge the system pressure. When the pressure is too high, this switch will disconnect and the unit will shut down.
- (14) The flow switch of the main unit is mainly used to judge the water flow. When the flow rate is too low, this switch will be disconnected; all loads except the water tank heater and the water pump of the solar system will stop. This error will be displayed at the controller and will be unrecoverable. The unit can restart only when it is repowered on and this error does not be displayed again.

Items from 1~14 listed above are control parameters input by the main unit.

- (15) The water tank temperature is detected by sensors immersed inside the water tank. These sensors can be divided into two groups. Group 1 is used to control the water tank temperature and group 2 is used to display the water tank temperature. When group 1 fails at the heating mode, this error will be displayed at the controller, and all loads except the water pump of the main unit will stop. When group 2 fails, this error also will be displayed at the controller but the unit continues normal operation.
- (16) The leaving and entering water temperature of the solar panel and also the solar panel temperature are detected by sensors installed at the inlet pipe, outlet pipe and solar panel of the solar system respectively. These sensors are mainly used to control the water pump of the hot water of the solar system. When the entering water temperature sensor fails, this error will be displayed at the controller and the unit continues normal operation. When other two sensors fail, this error also will be displayed at the controller and the water pump of the solar system will stop.
- (17) The remote room temperature is detected by the sensor installed at the room, which is mainly used to control the input capacity of the compressor through room temperature setting. When the main unit is controlled through the room temperature and this sensor fails, all loads except the water pump of the solar system and the electric heater of the water tank will stop. However, when the main unit is controlled through the leaving water temperature, if this sensor fails, this error will be displayed but the main unit will resume normal operation.
- (18) Only when the control function of the thermostat has been activated through the wired controller, then the thermostat can switch run modes among cooling, heating and shutdown, otherwise, the unit will run as per the run mode set by the wired controller.
- (19) The gate control function can be set to be "On" or "Off" at the function setting page of the wired controller. When this function has been activated and it is detected that the gate control card has been drawn out, the unit will shut down and will tell any key operation of the controller is invalid. Then, if it is detected that the gate control card has been inserted in, the unit will resume normal operation.
- (20) The flow switch of the solar system is mainly used to judge the water flow. When the flow rate is too low, the flow switch will disconnect and immediately the water pump of the solar system will stop. This error will be displayed at the controller and is unrecoverable. When this error is cleared, upon power on again, the unit will restart.

Items 15~ 20 are control parameters input by the field installed equipment.

## 1.2 Control Flowchart

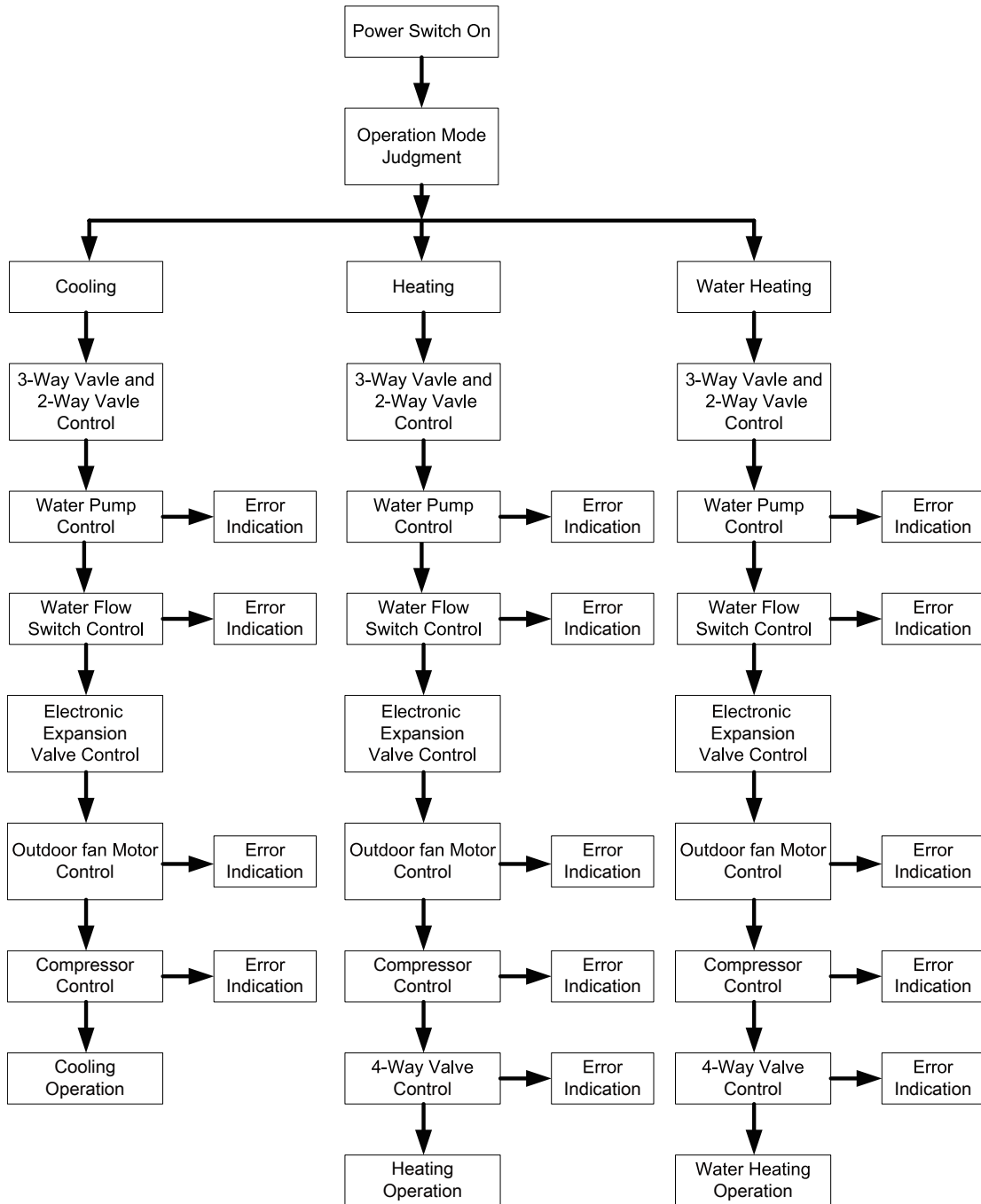

## 2 Main Control Logics

### 2.1 Cooling

#### 2.1.1 Control to the Compressor

When the unit is controlled by the leaving water temperature, the compressor operating frequency will be adjusted according to the temperature difference in direct proportion. (Temperature difference= actual leaving water temperature-leaving water temperature set point).

#### 2.1.2 Freeze Protection

When it is detected that the leaving water temperature of the plate heat exchanger is lower than the freeze protection temperature, the compressor will drop its operating frequency until it reaches the minimum operating frequency. Then if it is still detected that the leaving water temperature is lower than the freeze protection temperature, the main unit will stop as per the shutdown frequency but the water pump keeps normal operation.

When it is detected that the leaving water temperature of the plate heat exchanger is equal to or larger than the freeze protection withdrawing temperature, freeze protection will stop. At this point, once the compressor has stopped for three minutes and conditions for startup have been satisfied, the compressor will run for cooling.

## **2.2 Heating**

### **2.2.1 Control to the Compressor**

When the unit is controlled by the leaving water temperature, the operating frequency of the compressor will be adjusted by the temperature difference in the way that it increases as the temperature difference goes up and it decreases as the temperature difference goes down. When the compressor reaches the minimum frequency but the temperature frequency is still quite large, the unit will shut down (temperature difference= actual leaving water temperature-leaving water temperature set point).

### **2.2.2 Over-temperature Protection**

When the compressor is running and it is detected that the leaving water temperature of the auxiliary electric heater is higher than the over-temperature protection temperature, the compressor will lower its frequency to the minimal. Then if it is still detected that the leaving water temperature of the auxiliary electric heater is higher than the over-temperature protection temperature, all loads except the water pump of the main unit and the 4-way valve will stop. Over-temperature protection will stop until the leaving water temperature of the auxiliary electric heater is lower than the over-temperature withdrawing temperature. After that, the unit will resume normal operation.

## **2.3 Water Heating**

Water heating can be achieved by either the solar system or the main unit (heat pump).

### **2.3.1 Water Heating by the Main Unit**

- (1) When the outdoor temperature is out of the operation range, the compressor will not start, and water heating will be done by the water tank heater.
- (2) When the outdoor temperature is within the operation range, water heating will be done by the main unit. The output frequency of the compressor will be adjusted by the difference between the water tank temperature set point and the actual water tank temperature.
- (3) Control to the Water Tank Electric Heater
  - when the water tank temperature set point is lower than the maximum value of the water heating range of the main unit, the auxiliary electric heater of the main unit will run depending on the temperature difference, and the water tank keeps shut-down.
  - when the water tank temperature set point is higher than the maximum value of the water heating range of the main unit but the actual water tank temperature is lower than the maximum value of the water heating range of the main unit, the auxiliary electric heater of the main unit will run depending on the temperature difference. If the actual water tank temperature is higher than the maximum value of the water heating range of the main unit, the water tank heater will start. At any time, only one between the auxiliary electric heater and the water tank heater is allowed to run.
- (4) Over-temperature Protection for Water Heating

When the compressor is running, if it is detected that the leaving water temperature of the auxiliary electric heater of the main unit is higher than the over-temperature protection temperature, the compressor will lower its operating frequency until it reaches the minimal operating frequency. At this point, if it is still detected that leaving water temperature is still lower than the over-temperature protection, all loads except the water pump of the main unit and the 4-way valve will stop. Over-temperature protection will exit when the leaving water temperature is lower than the over-temperature protection temperature. Then, the main unit will resume normal operation.

### **2.3.2 Water Heating by the Solar System**

When the solar water heating system is equipped but temperature difference value ( it is the difference of solar panel temperature and the actual water tank temperature) for startup is not reached, the water pump of the solar system will not start. When the temperature difference value is reached, the water pump will start. However, when it is detected that the water tank temperature reaches the set point, or the entering/leaving water temperature difference of the solar panel is too small, then this water pump will stop running.

### **2.4 Shutdown**

There are three kinds of shutdown conditions: normal shutdown, shutdown with some error, shutdown for protection

Shutdown sequence: for normal shutdown, the compressor lowers its frequency firstly to the minimum value, while for shutdown with some error or for protection, the compressor will stop directly. Then, the electronic expansion valve turns to the maximum opening angle; the fan stops after the compressor has stopped; the water pump of the main unit stops after the compressor has stopped; the electronic expansion valve turns the maximum opening angle to the fixed opening angle.

During shutdown under the heating and water heating modes, the 4-way valve will be powered off after the compressor has stopped.

For shutdown owing to some error (except the communication error) or protection, the 4-way valve will keep the power-on status.

For shutdown owing to communication between the unit and the wired controller, the 4-way valve will be powered off some time later.

For shutdown with some error or for protection, the electronic expansion valve will keep the maximum opening angle.

### **2.5 Control to the Compressor**

When the unit is controlled by the leaving water temperature, the output frequency of the compressor is adjusted by the difference between the actual water temperature and the leaving water temperature set point. When the unit is controlled by the room temperature, the output frequency of the compressor is adjusted by the difference between the actual room temperature and the room temperature set point.

### **2.6 Control to the Fan**

Under the cooling mode, the operating frequency of the fan is adjusted according to pressure at the high pressure side. Under the heating or water heating mode, the operating frequency of the fan is adjusted according to the pressure at the low pressure side. During defrosting, the fan stops and resumes operation when defrosting ends up.

### **2.7 Control to the 4-way Valve**

The 4-way valve always keeps on under the cooling mode and will off after the compressor starts up under the heating or water heating mode. When the unit comes into defrosting, the 4-way valve will be on and resume the off status when defrosting ends up. For shutdown under the heating mode, the 4-way valve will be closed after the compressor stops.

### **2.8 Control to the Water Pump**

The water pump firstly will run at the initialized speed and then adjust the speed according to the entering/leaving water temperature difference. When the temperature difference is large, the fan runs at the high speed. When the temperature difference is small, the fan runs at the low speed.

### **2.9 Control the Electronic Expansion Valve**

There are two electronic expansion valves for two-stage throttling control. The opening angle of the first-stage electronic expansion valve is adjusted based on the ratio of readings of the high-pressure sensor, low-pressure sensor and enthalpy-adding sensor. The opening angle of the second-stage is adjusted based on the suction superheating degree.

## 2.10 Protection Control

### (1) Compressor Low-pressure Protection

When it is detected continuously that pressure at the low side is too low, then low-pressure protection will occur and this error will be displayed at the controller, all loads act as per the shutdown sequence. This error is unrecoverable and can be cleared unless repowered on.

### (2) High Discharge Temperature Protection

When it is detected continuously that the discharge temperature is higher than the recoverable temperature, the electronic expansion valve will turn to the maximum opening angle with large step until the discharge temperature is lower than the recoverable temperature. However, if this condition remains, the compressor will restrict the frequency output or lower its frequency three times. At any time, if it is detected that the discharge temperature is higher than the set point for protection for three seconds, the compressor will stop and the unit comes into high discharge temperature protection.

### (3) Compressor Hi-pressure Protection

In any case, when it is detected that the high-pressure switch acts, the unit will come into high-pressure protection three seconds later. This protection is unrecoverable.

### (4) Flow Switch Protection

In any case, when it is detected that the flow switch of the main unit disconnects, then all loads except the water pump of the solar system and the auxiliary electric heater of the water tank will stop. This protection is unrecoverable. The unit is allowed to be restart only after this error is cleared and the unit is repowered on.

### (5) Communication Error

When the indoor unit main board or drive board does not receive correctly any data from the unit main board, all loads will stop.



### 3 General













(This picture is just for reference)

This display panel uses the capacitor touch screen for input operation. The valid touching area indicates the black rectangle when the display panel lights off.

This control panel is of high sensitivity and will response to unexpected click by the foreign matters on the display panel. Therefore, please keep it clean during operation.

This is a generous-purpose controller, whose control functions might not be completely the same as those of the actually purchased. As the control program will update, the actual always prevails.

#### 3.1 Home Page

Icon	Description	Icon	Description
	Space heating		Outdoor temperature
	Space cooling		Leaving water temperature of the main unit, leaving water temperature of the auxiliary electric heater, remote room temperature
	Water heating		Error
	Menu		Card out/Failed disinfection
	Switchover between cooling and heating		ON/OFF
	Child lock		

[Notes]

- The ON/OFF icon will turn to green when the control is turned on.
- When the control mode is “**Room temperature**”, the temperature displayed at the upper right corner indicates the remote room temperature; when the control mode is “**leaving water temperature**”, it indicates the leaving water temperature of the auxiliary electric heater under the water heating mode, or the leaving water temperature of the main unit under the cooling/heating mode or combined modes.
  - Under the combined modes, the temperature set point is for space heating or cooling. Only under the water heating mode, it is for water heating.
- It will go back automatically to the homepage when there is no any operation in ten minutes.



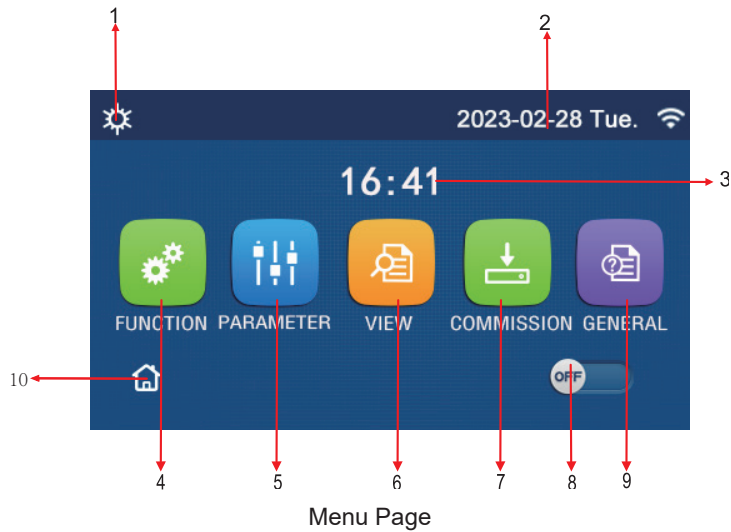



### 3.2 Menu Page



Above the menu, the corresponding icon will be displayed based on the mode and status of the controller.

No.	Item	Description
1	Current mode	Current mode
2	Date	Current date
3	Time	Current time
4	Function setting	Go to the user setting page.
5	Parameter setting	Go to the parameter setting page.
6	Parameter viewing	Go to the parameter viewing page.
7	Commissioning parameters	Go to the commissioning parameter setting page.
8	ON/OFF	It is used to turn on or off the controller.
9	General setting	Go to the general parameter setting page.
10	Homepage	Back to the home page.

Icon	Description	Icon	Description
	Heating		Floor commissioning
	Cooling		Floor commissioning error
	Hot water		Card out
	Heating + Hot water		Defrosting
	Hot water + Heating		Holiday
	Cooling + Hot water		WiFi
	Hot water + Cooling		Back

Icon	Description	Icon	Description
	Quiet		Menu page
	Disinfection		Save
	Emergency		Error

[Notes]

- The “**Cooling**” mode is unavailable to the heating only unit.
- The “**Hot water**” mode is unavailable for the unit not equipped with a water tank.

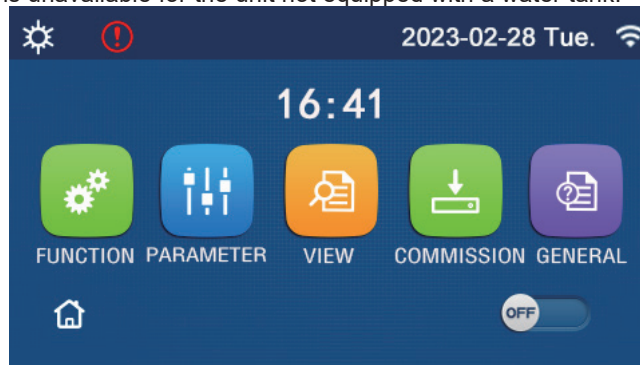

Error Icon

### 3.3 Backlight

Among the general setting page, when “**Back light**” is set to “**Energy save**”, the display panel will light off when there is no operation in 5 minutes. However, it will light on again by touching any valid area.

When “**Back light**” is set to “**Lighted**”, the display panel will be kept lighting on.

It is suggested to set it to “**Energy save**” so as to extend its service life.

## 4 Operation Instructions

### 4.1 ON/OFF

[Operation Instructions]

At the menu page, by touching ON/OFF, the unit will be turned on/off.

[Notes]

- It is defaulted to be OFF upon first power-on.
- ON/OFF operation will be memorized by setting “**On/Off Memory**” to be “**On**” at the “**GENERAL.**” setting page. That is, in case of power failure the unit will resume running upon power recovery. Once “**On/off Memory**” is set to be “**Off**”, in case of power failure the unit will keep “**Off**” upon power recovery.

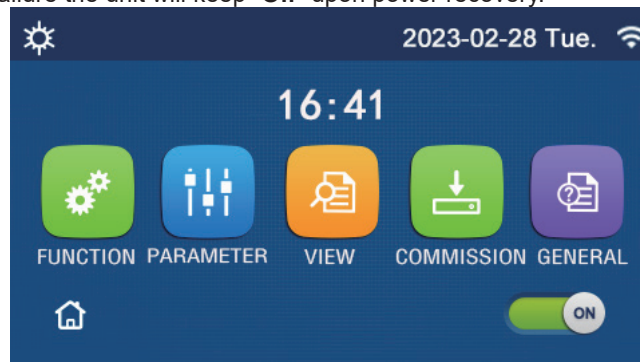

ON Page

## 4.2 Function Setting

[Operation Instructions]

1. At the menu page, by touching “**FUNCTION**”, it will go to the function setting page as shown in the figure below.

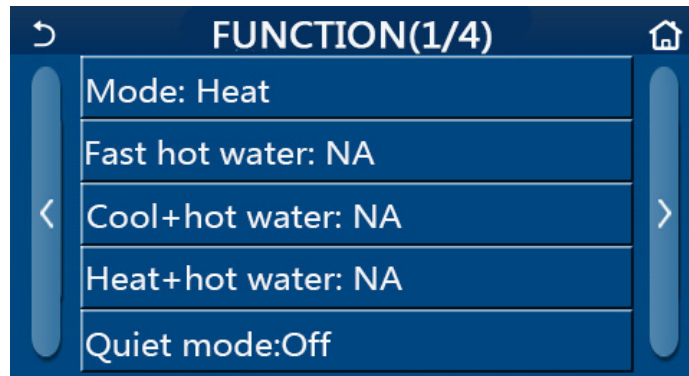

FUNCTION Setting Page

2. At the function setting page, by touching the page turning key, it will access to the last or next page. When setting is finished, by touching the menu page icon, it will directly back to the menu page; by touching the back icon, it will back to the upper menu.

3. At the function setting page, by pressing the desired function, it will access to the corresponding setting page of this option.

4. At the function setting page of some function option, by touching “**OK**”, this setting will be saved; by touching the “**CANCEL**” key, this setting will be canceled.

[Notes]

- At the function setting page with setting of any function changed, if the function is set to be memorized upon power failure, this setting will be saved automatically and memorized upon next power-on.

- When there is submenu for the selected function option, by pressing it the control will go directly the setting page of the submenu.

- “NA” will be displayed for unavailable functions of the heating only units. When setting these functions, the controller will tell setting of this parameter is unallowed.

### Function Setting

No.	Item	Range	Default	Remarks
1	Mode	Cool	Heat	1. When the water tank is unavailable, then only “ <b>Cool</b> ” and “ <b>Heat</b> ” are available. 2. For the heating only unit, only “ <b>Heat</b> ” mode, “Hot water”, and “Heat + hot water” are available. 3. It is defaulted to be “ <b>Heat</b> ” for the heat pumps and heating only units.
		Heat		
		Hot water		
		Cool + Hot water		
		Heat + Hot water		
2	Fast hot water	On/Off	Off	When the water tank is unavailable, it will be reserved.
3	Cool + hot water	Cool/Hot water	Hot water	When the water tank is available, it will be defaulted to be “ <b>Hot water</b> ”; when unavailable, it will be reserved.
4	Heat + hot water	Heat/Hot water	Hot water	When the water tank is available, it will be defaulted to be “ <b>Hot water</b> ”; when unavailable it will be reserved.
5	Quiet mode	On/Off/Timer	Off	/
6	Weather depend	On/Off	Off	/
7	Weekly timer	On/Off	Off	/

No.	Item	Range	Default	Remarks
8	Holiday release	On/Off	Off	/
9	Disinfection	On/Off	Off	When the water tank is unavailable, it will be reserved The disinfection date ranges from Monday to Sunday. Saturday is defaulted. 23:00. The disinfection time ranges from 00:00~23:00. 23:00 is defaulted.
10	Clock timer	On/Off	Off	/
11	Temp. timer	On/Off	Off	/
12	Emergen. mode	On/Off	Off	/
13	Holiday mode	On/Off	Off	/
14	Preset mode	On/Off	Off	/
15	Error reset	/	/	Some error can be cleared only when it has been reset manually.
16	WiFi reset			It is used to reset the WiFi.
17	Reset	/	/	It is used to reset all user parameter setting.
18	Child Lock	On/Off	Off	/

#### 4.2.1 Mode

[Operation Instructions]

At the function setting page with the unit turned off, by touching **"Mode"**, it will go to the mode setting page, where desired mode can be selected. Then by touching **"OK"** this setting will be saved and the display panel will back to the function setting page.

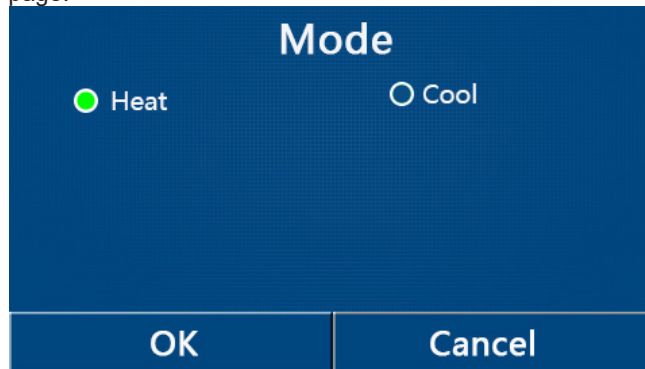

[Notes]

- The default mode is **"Heat"** upon first power-on.
- Mode setting is allowed only when the unit is turned off, otherwise a dialog box will pop up, saying "Please turn off the system first!"
- When the water tank is unavailable, only **"Heat"** and **"Cool"** mode are allowed.
- When the water tank is available, **"Cool"**, **"Heat"**, **"Hot water"**, **"Cool+ Hot water"**, and **"Heat+ Hot water"** are allowed.
- For the heat pump, the **"Cool"** mode is allowed; for the heating only unit, **"Cool+ Hot water"** and **"Cool"** are unallowable.
- This setting can be memorized upon power failure.

#### 4.2.2 Fast hot water

[Operation Instructions]

At the function setting page with the unit turned off, by touching “**Fast hot water**”, the display panel will go to the corresponding setting page, where desired option can be selected. Then by pressing “**OK**” this setting will be saved and the display panel will back to the function setting page.

[Notes]

- This function can be set to “**On**” only when the water tank is available. When the water tank is unavailable, this function will be reserved.
- It will be memorized upon power failure.

#### 4.2.3 Cool + hot water

[Operation Instructions]

At the function setting page with the unit turned off, by touching “**Cool + hot water**”, the display panel will go to the corresponding setting page, where desired option can be selected. Then by pressing “**OK**” this setting will be saved and the display panel will back to the function setting page.

[Notes]

- When the water tank is unavailable, it will be reserved; when it is available, the default priority will be given to “**Hot water**”.
- It will be memorized upon power failure.

#### 4.2.4 Heat + hot water

[Operation Instructions]

At the function setting page with the unit turned off, by touching “**Heat + hot water**”, the display panel will go to the corresponding setting page, where desired option can be selected. Then by pressing “**OK**” this setting will be saved and the display panel will back to the function setting page.

[Notes]

- When the water tank is unavailable, it will be reserved; when it is available, the default priority will be given to “**Hot water**”.
- It will be memorized upon power failure.

#### 4.2.5 Quiet mode

[Operation Instructions]

At the function setting page with the unit turned off, by touching “**Quiet mode**”, there will be a choice box, where “**Quiet mode**” can be set to “**On**”, “**Off**”, or “**Timer**”.

When it is set to “**Timer**”, it is also required to set the “**Start timer**” and “**End timer**”. Unless otherwise stated, otherwise time setting is all the same.

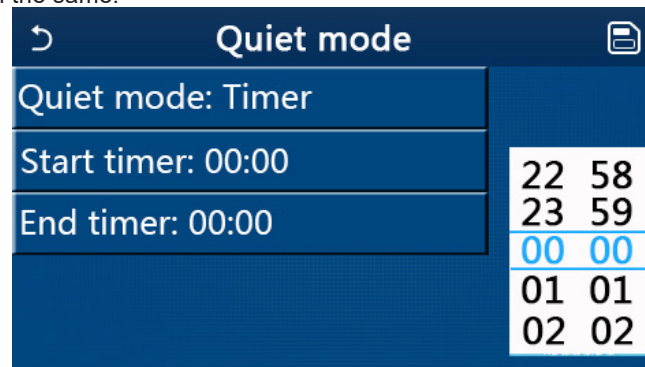

Timer for Quite Mode

This setting will be saved by touching the corner at the upper right corner.

[Notes]

- It can be set under both ON and OFF statuses, but will work only when the main unit is turned on.

- When it is set to “On”, it will automatically back to “Off” when the main unit is turned off; while it is set to “Timer”, this setting will remain when the main unit is turned off and can only be canceled manually.
- It will be memorized upon power failure.

#### 4.2.6 Weather depend

[Operation Instructions]

At the function setting page, by touching “Weather depend”, there will be a choice box, where it is able to set it to “On” or “Off”, and also it is able to set the weather-dependent temperature.

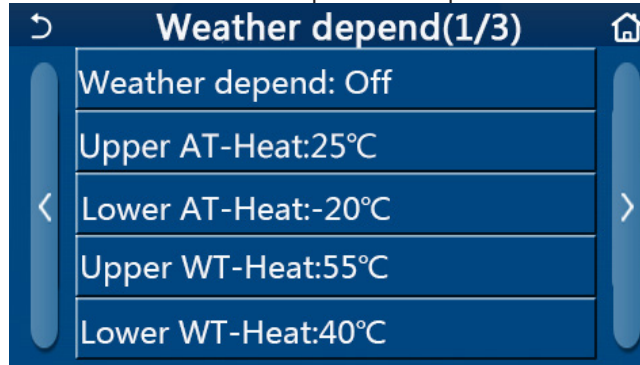

Page of the Weather Depend

[Notes]

- When “Weather depend” has been activated; it cannot be deactivated by ON/OFF operation but done manually.
  - It is available to find the weather-dependent target temperature at that parameter viewing pages.
  - When this function has been activated, it is still allowed to set the room temperature, however, this setting becomes valid only when “Weather depend” has been deactivated.
  - This function can be set to “On” no matter the unit is turned on or off, but works only when the unit is turned on.
    - It works under the “Cool” or “Heat” mode. Under the “Cool +Hot water” or “Heat +Hot water” modes, it works only when the current mode is “Cool” or “Heat”. Under the “Hot water” mode, it doesn’t work.
    - Temperature setting relative to the cooling mode is unallowed to the heating only unit.
    - It will be memorized upon power failure.
    - When the set point of “Upper WT-Heat”/ “Upper WT-Cool” is lower than that of the “Lower WT-Heat”/ “Lower WT-Cool”, or “Lower WT-Heat”/ “Lower WT-Cool” is higher than “Upper WT-Heat”/ “Upper WT-Cool”, a window will pop up, saying “Enter wrong!”, and then resetting is required.

#### 4.2.7 Weekly timer

[Operation Instructions]

1.At the function setting page, by touching “Weekly timer”, it will go to the setting page as shown below.



2.At the “Weekly timer” setting page, as shown in the figure below, the weekly timer can be set to “On” or “Off”.

3.At the “Weekly timer” setting page, by touching the desired day (Monday~Sunday) it will access to the setting page of this option.



4. At the weekday setting page, it is able to set the timer to **“Valid”**, **“Invalid”** or **“Holiday”**, . Also, it is able to set three timing periods, each of which can be set to **“Valid”** or **“Invalid”**.

5. Then, by touching the **“Save”** icon, this setting will be saved.

[Notes]

- Three periods can be set for each day. The start time should be earlier than the end time for each period, otherwise this setting will be invalid. In the same way, the latter should be earlier than the former.

- When the weekly timer has been activated, the display panel will act based on the current mode and temperature setting.

- Timer setting for the weekday

**“Valid”** it indicates this setting works only when **“Weekly timer”** has been activated, unaffected by the holiday mode.

**“Invalid”** indicates this setting does not work even though the **“Weekly timer”** has been activated.

**“Holiday”** indicates when both **“Weekly timer”** and **“Holiday release”** have been activated, setting of **“Weekly timer”** is invalid. Only when **“Holiday release”** has been deactivated, setting of **“Weekly timer”** works.

- The priority sequence for timer setting from high to low is **“Temperature timer”**, **“Clock timer”**, **“Preset mode”** and **“Weekly timer”**. Setting with lower priority sequence is allowed but does not work when setting with higher priority has been activated. However, it will work when the setting with higher priority has been deactivated.

- It will be memorized upon power failure.

#### 4.2.8 Holiday release

[Operation Instructions]

At the function setting page, by touching **“Holiday release”**, it will go to the corresponding setting page, where it can be set to **“On”** or **“Off”**.

[Notes]

- When this function has been activated, at the **“Weekly timer”** setting page, some week day can be set to **“Holiday release”**. In this case, the setting of the **“Weekly timer”** at this day is invalid unless it has been manually set to **“Valid”**.

- It will be memorized upon power failure.

#### 4.2.9 Disinfection

[Operation Instructions]

1. At the function setting page, access to **“Disinfection”** setting page.

2. At the **“Disinfection”** setting page, it can select the disinfection clock, disinfection temperature and disinfection week and the corresponding setting page will pop up at the right side.

3. Then, this setting will be saved by touching the **“Save”** icon.

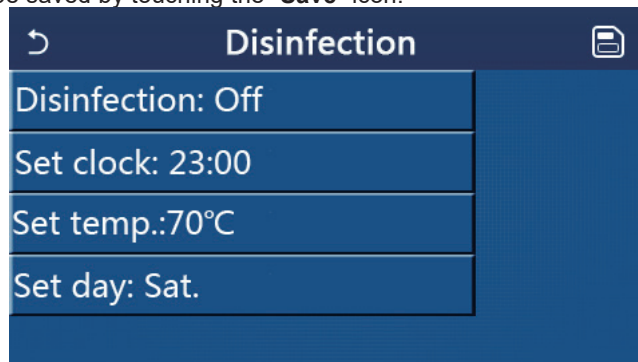

[Notes]

- This setting can be activated only when **“Water tank”** is set to **“With”**. When **“Water tank”** is set to **“Without”**, this function will be deactivated.

- This setting can be done no matter if the unit is turned on or off.



- When “**Emergen.mode**”, “**Holiday mode**”, “**Floor debug**”, “**Manual defrost**”, or “**Refri. recovery**” has been activated, this function cannot be activated at the same time. When “**Disinfection**” has been activated, “**Emergen. mode**”, “**Holiday mode**”, “**Floor debug**”, “**Manual defrost**”, or “**Refri. recovery**” setting will fail and a window will pop up, saying “**Please disable the disinfect mode!**”

- “**Disinfection**” can be activated no matter if the unit is turned on or off. This mode will take priority over the “**Hot water**” mode.

- When disinfection operation fails, the display panel will tell “**Disinfection fail!**”. Then, by pressing OK it will be cleared.

- When “**Disinfection**” has been activated, if communication error with the indoor unit or malfunction of the water tank heater occurs, it will automatically quit.

- It will be memorized upon power failure.

#### 4.2.10 Clock timer

[Operation Instructions]

1.At the function setting page, access to the “**Clock timer**” setting page.

2.At the “**Clock timer**” setting page, it can be set to “**On**” or “**Off**”.

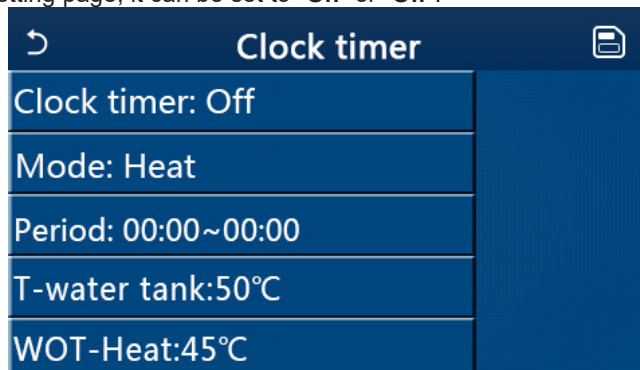

3.The option “**Mode**” is used to time the desired mode; “**WOT-Heat**” and “**T-water tank**” is used to set the corresponding water temperature; “**Period**” is used to for time setting. After that, by touching the “**Save**” icon, all settings will be saved.



[Notes]

- When “**Clock timer**” has been set and “**Hot water**” mode is involved, in this case, if “**Water tank**” is changed to “**Without**”, “**Hot water**” will be automatically switched to “**Heat**”, and “**Cool/Heat + Hot water**” will be switched to “**Cool/Heat**”.

- When “**Weekly timer**” and “**Clock timer**” have been set at the same time, the priority will be given to the former.

- When the water tank is available, “**Heat**”, “**Cool**”, “**Hot**”, “**Heat + Hot water**”, and “**Cool + Hot water**” are allowed; however, when the water tank is unavailable, only “**Heat**” and “**Cool**” are allowed.

- When the end time is earlier than the start time, this setting is invalid.

- Water tank temperature can be set only when “**Hot water**” is involved in the operation mode.

- The setting of “**Clock timer**” only works once. If this setting is needed again, it should be set again.

- It will be deactivated when the unit is turned on manually.
- When “Weather depend” has been activated and the mode for “Clock timer” is set to “Hot water”, “Weather depend” will be deactivated when the setting mode has been switched.
- This function will be memorized upon power failure.

#### 4.2.11 Temp. timer

At the function setting page, access to the “Temp.timer” setting page.

At the “Temp.timer” setting page, it can be set to “On” or “Off”.

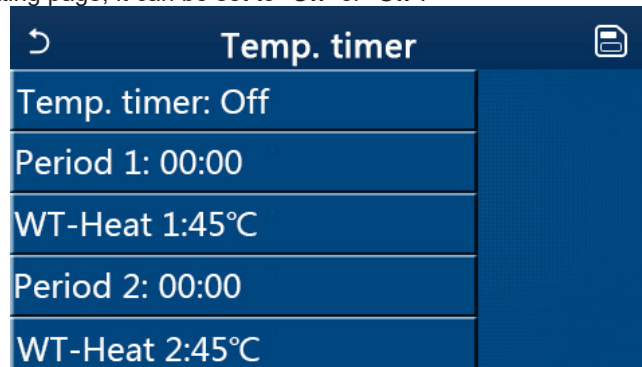

Select “Period 1”/“Period 2” and a window will pop up, where time period can be set. Then select “WT-Heat1/WT-Cool 1/2” and also a window will pop up where temperature can be set.



[Notes]

- When “Weekly timer”, “Preset mode”, “Clock timer” “Temp. timer” have been set at the same time, then the latter takes the priority.
- This setting is valid only when the unit is turned on.
- Under the “Cool” or “Cool+Hot water” mode, the setting targets at “WT-Cool”; while under the “Heat” or “Heat+Hot water” mode, the setting targets at “WT-Heat”.
- When start time of period 2 is the same as that of period 1, then the former takes prevalence.
- “Temp.timer” is judged based on timer.
- During this setting, when temperature is set manually, then this setting will take prevalence.
- Under the “Hot water” mode, this function will be reserved.
- This function will be memorized upon power failure.

#### 4.2.12 Emergen. mode

[Operation Instructions]

1. At the function setting page, set the mode to “Heat” or “Hot water”.
2. At the function setting page, select “Emergen.mode” and set it to “On” or “Off”.
3. When “Emergen.mode” has activated, the corresponding icon will appear at the upper side of the menu page.
4. When the mode is not set to “Heat” or “Hot water”, the display panel will tell “Wrong running mode!”

[Notes]

- The emergency mode is allowed on conditions that there is some error or protection and the compressor has stopped at least for three minutes. If the error or protection has not been recovered, the unit can access to the emergency mode through the wired controller (when the unit is off).

- Under the emergency mode, “**Hot water**” or “**Heat**” cannot be performed at the same time.

- When the running mode is set to “**Heat**”, if “**Other thermal**” or “**Optional E-Heater**” is set to “**Without**”, the unit will fail to access to the “**Emergen. mode**”.

- When the unit performs “**Heat**” under “**Emergen. mode**” and the controller detects “**HP-Water Switch**”, “**Auxi. heater 1**”, “**Auxi. heater 2**”, and “**Temp-AHLW**”, this mode will quit at once. In the same way, when errors mentioned above occur, “**Emergen. mode**” cannot be activated.

- When the unit performs “**Hot water**” under “**Emergen. mode**” and the controller detects “**Auxi.-WTH**”, this mode will quit at once. In the same way, when errors mentioned above occur, “**Emergen. mode**” cannot be activated.

- When this function has been activated, “**Weekly timer**”, “**Preset mode**”, “**Clock timer**”, and “**Temp timer**” will be deactivated. Beside “**On/Off**”, “**Mode**”, “**Quiet mode**”, “**Weekly timer**”, “**Preset mode**”, “**Clock timer**”, and “**Temp timer**” operation are unavailable.

- Under “**Emergen. mode**”, the thermostat does not work.

- This function can be activated only when the unit is turned off. If dosing so with the unit keeping “**On**”, a window will pop up, saying “**Please turn off the system first!**”.

- “**Floor debug**”, “**Disinfection**”, and “**Holiday mode**” cannot be activated at the same with this function. When doing so, a window will pop up, saying “**Please disable the emergen. mode!**”.

- Upon power failure, “**Emergen. mode**” will back to “**Off**”.

#### 4.2.13 Holiday mode

[Operation Instructions]

At the function setting page, select “**Holiday mode**” and set it to “**On**” or “**Off**”.

[Notes]

- This function can be activated only when the unit has been turned off, otherwise a prompt dialog box will pop up, saying “**Please turn off the system frist!**”.

- When “**Holiday mode**” has been activated, the operation mode will automatically switch to “**Heat**”. Mode setting and “**On/Off**” operation through the controller will be unavailable.

- When “**Holiday mode**” has been activated, the controller will automatically deactivate the “**Weekly timer**” and “**Preset mode**” and “**Clock timer**” and “**Temp.timer**”.

- Under the “**Holiday mode**”, when the unit is under the control of room temperature, the set point (room temperature for heating) should be set to 10°C; when it is under the control of leaving water temperature, the set point (leaving water temperature for heating) should be 30°C.

- When this function has been activated, “**Floor debug**”, “**Emergen.mode**”, “**Disinfection**”, “**Manual defrost**”, “**Preset mode**”, “**Weekly timer**”, “**Clock timer**”, and “**Temp.timer**” cannot be activated at the same time, meanwhile a window will pop up, saying “**Please disable the holiday mode!**”.

- This function will be memorized upon power failure.

#### 4.2.14 Preset mode

[Operation Instructions]

At the function setting page, select “**Preset mode**” and go to the corresponding setting page.

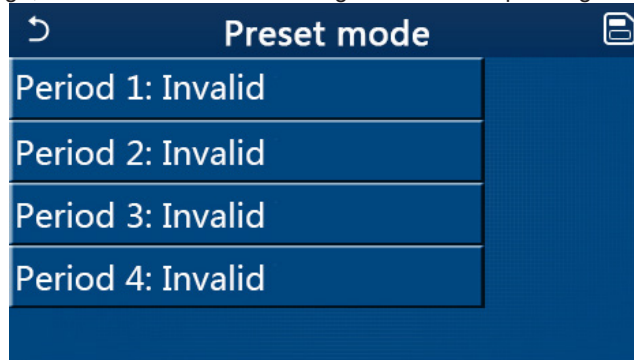

At the time period setting page, each time period can be set to “**Valid**” or “**Invalid**”.

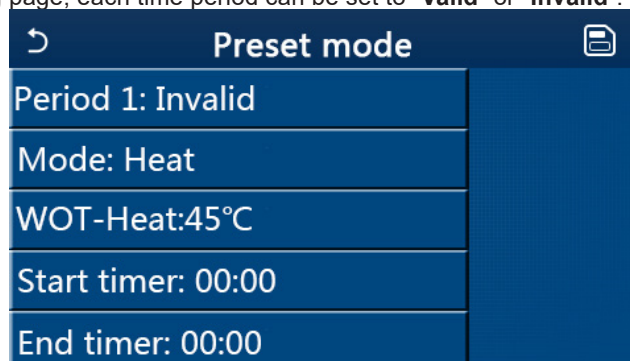

The option “**Mode**” is used to preset the mode; “**WOT-Heat**” is used to set the leaving cold/hot water temperature; “**Start timer**”/“**End timer**” is used to for time setting. After that, by touching the “**Save**” icon, all settings will be saved.

[Notes]

- When “**Preset mode**” has been set to “**Hot water**” and “**Water tank**” is to set to “**Without**”, the preset “**Hot water**” mode will be automatically switched to “**Heat**”.
- When “**Weekly timer**” and “**Preset mode**” both have been set, priority will be given to the latter.
- When the water tank is available, the preset mode can be “**Heat**”, “**Cool**”, or “**Hot water**”; however, when the water tank is unavailable, the preset mode can only be “**Heat**” or “**Cool**”.
- “**Start timer**” should be earlier than “**End timer**”, otherwise a dialog will pop up, saying “**time setting wrong**”.
- The setting for “**Preset mode**” will works until it has been canceled manually.
- When “**Start timer**” is reached, the unit will perform the preset mode. In this case, mode and temperature setting are still allowed but will not be saved to the preset mode. When “**End timer**” is reached, the unit will perform OFF operation.
  - This function will be memorized upon power failure.
  - When “**Weather depend**” has been activated and the mode for “**Preset mode**” is set to “**Hot water**”, “**Weather depend**” will be deactivated when the setting mode has been switched.

#### 4.2.15 Error reset

[Operation Instructions]

At the function setting page, by touching “**Error reset**”, a choice box will pop up, where by touching “**OK**” the error will be reset and by touching “**Cancel**” the error will not be reset.

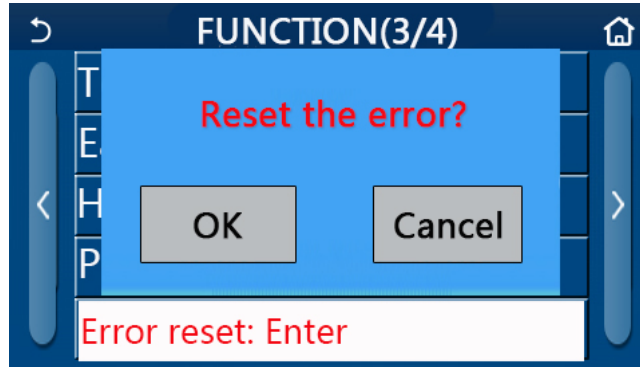

[Notes]

- It can be performed only when the unit is turned off.

#### 4.2.16 WiFi reset

[Operation Instructions]

At the function setting page, by touching "WiFi reset", a choice box will pop up, where by touching "OK", the WiFi setting will be reset, and by touching "Cancel" the choice box will quit and WiFi will not be reset.

#### 4.2.17 Reset

[Operation Instructions]

At the function setting page, by touching "Reset", a choice box will pop up, where by touching "OK" all user parameter settings will be reset and by touching "Cancel" it will back to the function setting page.

[Notes]

- This function is allowed only when the unit has turned off.
- This function is valid for "Temp. timer", "Clock timer", "Preset mode", "Weekly timer", and "Weather depend".

#### 4.2.18 Child lock

[Operation Instructions]

At the function setting page, by touching "Child Lock", it can be set to "On" or "Off".

When it is set to "On", the controller will go back to the home page and a lock icon will be displayed, as shown in the figure below.

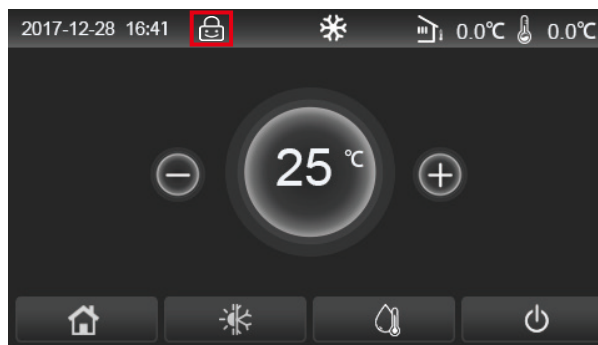

In this case, the controller is locked and any touch operation does not work. By touching  for six seconds, the controller will be unlocked and touch operation will work. However, the setting of "Child Lock" will remain to be "On", and if there is no any operation in 30 seconds, the controller will be locked again.

Only when it is set to "Off", this function will be really disenabled.

### 4.3 User Parameter Setting

[Operation Instructions]

1. At the menu page, by touching "PARAMETER", it will back to the parameter setting page, as shown in the figure below.

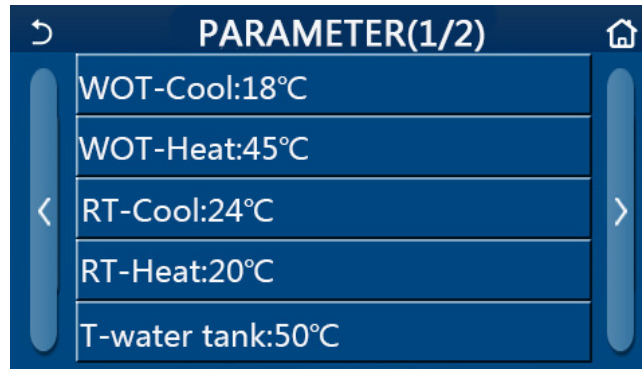

Parameter Setting Page

2. At the menu setting page, by touching the page turning keys, it is able to switch to the page where the desired parameter is.

3. After that, this setting will be saved by touching "OK" and then the unit will run based on this setting. While this setting will give up by touching "Cancel".

[Notes]

For parameters with different defaults under different conditions, when conditions changes, the default value also will change as the corresponding condition changes.

All parameters will be memorized upon power failure.

**Parameter Setting**

No.	Full Name	Displayed Name	Range	Range	Default	Remarks
			(°C)	(°F)		
1	Leaving water temperature for cooling(T1)	WOT-Cool	5~25°C	41~77°F	18 C/64°F	Unavailable to heating only units
2	Leaving water temperature for heating (T2)	WOT-Heat	20~65°C	68~149°F	45°C/113°F	
3	Room temperature for cooling (T3)	RT-Cool	18~30°C	64~86°F	24°C/75°F	Unavailable to heating only units
4	Room temperature for heating (T4)	RT-Heat	18~30°C	64~86°F	20°C/68°F	/
5	Water tank temperature(T5)	T-water tank	40~80°C	104~176°F	50°C/122°F	
6	Leaving water temperature difference for cooling (Δt1)	ΔT-Cool	2~10°C	36~50°F	5°C/41°F	
7	Leaving water temperature difference for heating (Δt2)	ΔT-Heat	2~10°C	36~50°F	10°C/50°F	/
8	Leaving water temperature difference for water heating (Δt3)	ΔT-hot water	2~25°C	36~77°F	5°C/41°F	
9	Room temperature control difference (Δt4)	ΔT-Room temp	1~5°C	34~41°F	2°C/36°F	/

#### 4.4 Commissioning Parameter Setting

[Operation Instructions]

1. At the menu page, by touching “**Commission**” and then entering the correct password (000048) in the pop-up window, the commissioning parameter page will be accessed, where the left side is for the function setting and the right side is for the parameter setting, as shown in the figure below.

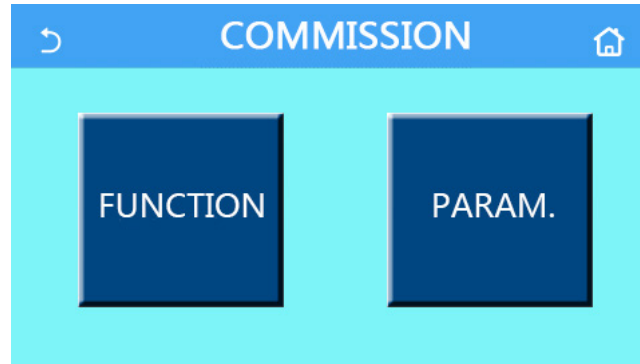

[Notes]

• At the commissioning parameter setting page, when the state of any function changes, the system will automatically save this change and this change will remain upon power failure.

• Do not modify any commissioning parameter except the approved qualified servicemen, as it would give birth to adverse effects to the unit.

##### Commissioning Function Setting

No.	Item	Range	Default	Description
1	Ctrl. state	T-water out/T-room	T-water out	When “ <b>Remote sensor</b> ” is set to “ <b>With</b> ”, it can be set to “ <b>T-room</b> ”.
2	2-Way valve	Cool 2-Way valve, On/Off	Off	It will decide the status of the 2-way valve under the “ <b>Cool</b> ” and “ <b>Cool + Hot water</b> ” modes. Under “ <b>Cool</b> ” or “ <b>Cool + Hot water</b> ” mode, the status of the 2-way valve depends on this setting. This setting is unavailable to heating only units.
		Heat 2-Way valve, On/Off	On	It will decide the status of the 2-way valve under the “ <b>Heat</b> ” and “ <b>Heat + Hot water</b> ” modes
5	Solar setting	With/Without	Without	When the water tank is unavailable, this setting will be reserved. When it is set to “ <b>With</b> ”, the solar kitting will work on its own. When it is set to “ <b>Without</b> ”, hot water by the solar kitting is unavailable.
6	Water tank	With/Without	Without	/
7	Thermostat	Without/Air/Air+ hot water/ Air+ hot water2	Without	This setting cannot be interchanged among “ <b>Air</b> ”, “ <b>Air+ hot water</b> ” and “ <b>Air+ hot water2</b> ” directly but via “ <b>Without</b> ” this option.
8	Other thermal	With/Without	Without	/
9	Optional E-Heater	Off/1/2	Off	/
10	Remote sensor	With/Without	Without	When it set to “ <b>Without</b> ”, and the “ <b>Ctrl. state</b> ” will be defaulted to be “ <b>T-water out</b> ”.
11	Air removal	On/Off	Off	/
12	Floor debug	On/Off	Off	/
13	Manual defrost	On/Off	Off	/



No.	Item	Range	Default	Description
14	Force mode	Off/Force-cool/Force-heat	Off	"Force-cool" is unavailable to heating only units.
15	Tank heater	Logic 1/Logic 2	Logic 1	This setting is allowed when the water tank is available and the unit is OFF.
16	Gate-Ctrl.	On/Off	Off	/
17	C/P limit	Off/Current limit/Power limit	Off	Current limit: it ranges from 0 to 50A and the default is 16A. Power limit: it ranges from 0.0 to 10.0kW and the default is 3.0kW.
18	Address	[1-125] [127-253]	1	/
19	Refri. recovery	On/Off	Off	/
20	Gate-Ctrl memory	On/Off	Off	/
21	3-Way valve1	Without/DHW/AIR	Without	/
22	Hot water control mode	Auto/Manual	Auto	

**Commissioning Parameters Setting**

No.	Full Name	Display Name	Range		Default	Remark
1	T-HP max	T-HP max	40~55°C	104~131°F	50°C/122°F	When the water tank is unavailable, this setting will be reserved.

**4.4.1 Ctrl. state**

[Operation Instructions]

At the commissioning parameter setting page, by touching "**Ctrl. state**", it can be set to "**T-water out**" or "**T-room**"

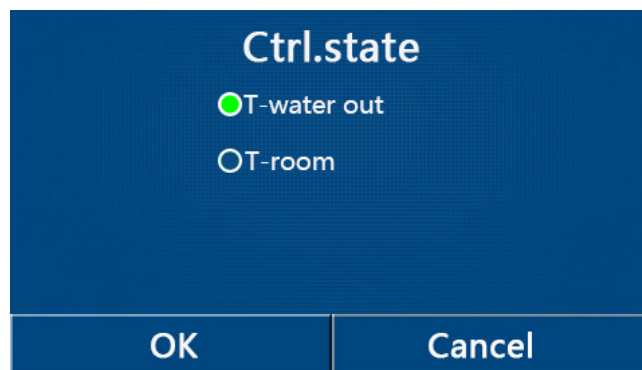

[Notes]

• When "**Remote sensor**" is set to "**With**", this setting can be set to "**T-water out**" or "**T-room**". When "**Remote sensor**" is set to "**Without**", this setting can only be set to "**T-water out**".

• This setting will be memorized upon power failure.

**4.4.2 2-Way valve**

[Operation Instructions]

At the commissioning parameter setting page, by touching "**Cool 2-Way valve**" or "**Heat 2-Way valve**", the control panel will access to the corresponding setting page.



[Notes]

- This setting is unavailable to heating only units.
- Under “Cool”, or “Cool + Hot water” mode, “Cool 2-Way valve” will decide the status of the 2-way valve; while under “Heat” or “Heat + Hot water”, “Heat 2-Way valve” will decide the status of the 2-way valve.
- It will be memorized upon power failure.

#### 4.4.3 Solar setting

[Operation Instructions]

1. At the commissioning parameter setting page, by touching “Solar setting”, the control panel will access to its submenu page.
2. At the submenu page, “Solar setting” can be set to “With” or “Without”.
3. At the submenu page, the “Solar heater” can be set to “On” or “Off”.



Solar Setting

[Notes]

- This setting can be done no matter if the unit is turned on or off.
- This setting is allowed only when the water tank is available. When the water tank is unavailable, this setting will be reserved.
- It will be memorized upon power failure.

#### 4.4.4 Water tank

[Operation Instructions]

At the commissioning parameter setting page, by touching “Water tank”, the control panel will access to the corresponding setting page, where “Water tank” can be set to “With” or “Without”.

[Notes]

- This setting will be memorized upon power failure.
- This setting will become valid only when the unit is turned off.

#### 4.4.5 Thermostat

[Operation Instructions]

1. At the commissioning parameter setting page, by touching “Thermostat”, the control panel will access to the corresponding setting page.

2. At the “Thermostat” setting page, it can be set to “Air”, “Without”, “Air + hot water” and “Air + hot water2”. When it is set to “Air”, “Air + hot water” or “Air + hot water2”, the unit will run based on the mode set by the thermostat; when it is set to “Without”, the unit will run based on the mode set by the control panel.

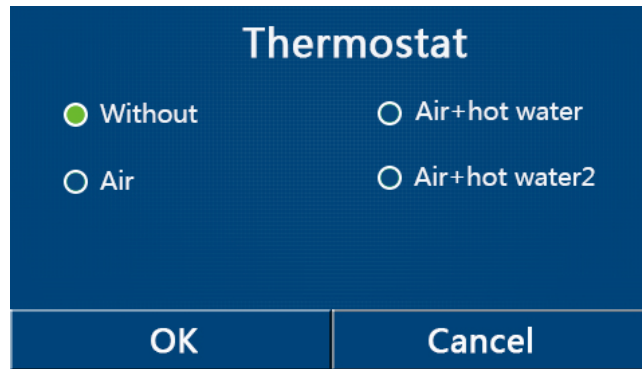

[Notes]

- When “Water tank” is set to “Without”, the “Air + hot water” or “Air + hot water2” mode is unavailable.
- When “Floor debug” and “Emergen.mode” have activated, function of the thermostat will be invalid.
- When “Thermostat” is set to “Air”, “Air + hot water” or “Air + hot water2”, “Temp.timer” will be deactivated automatically and the unit will run based on the mode set by the thermostat. Meanwhile, mode setting and On/Off operation by the control panel will be ineffective.
  - When “Thermostat” is set to “Air”, the unit will run based on the setting of the thermostat.
  - When “Thermostat” is set to “Air + hot water”, when the thermostat is turned off, the unit can still perform the “Hot water” mode. In this case, the ON/OFF icon at the homepage does not indicate the running status of the unit. Running parameters are available at the parameter viewing pages.
  - When “Thermostat” is set to “Air + hot water”, operation priority can be set by the control panel (see Section 2.2.3 and 2.2.4 for more details.)
  - When the “Thermostat” is set to “Air + hot water2”, there are two kinds of responses for the units. For one, if CN26 receives the “OFF” signal (dry contact, 0Vac), the unit will take the priority to “Hot water”. Once operation conditions for “Hot water” are ready, the unit will run for “Hot water”. Then, when “Hot water” is satisfied, the unit will run on the demands of the thermostat. For the other, if CN26 has not received the “OFF” signal, the unit will run on the demands of the thermostat.

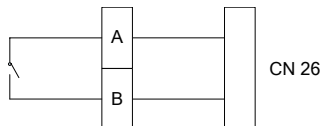

- The status of the thermostat can be changed only when the unit is turned off.
- When it has been activated, “Floor debug”, “Air removal”, and “Emergen.mode” are not allowed to be activated.
- This setting will be memorized upon power failure.

#### 4.4.6 Other thermal

[Operation Instructions]

- 1.At the commissioning parameter setting page, by touching “Other thermal”, the control panel will access to the corresponding setting page.
- 2.At the “Other thermal” setting page, “Other thermal” can be set to “With” or “Without”, “T-Other switch on” can be set to the desired value. When “Other thermal” is set to “With”, it is allowed to set the operating mode for the backup thermal source.

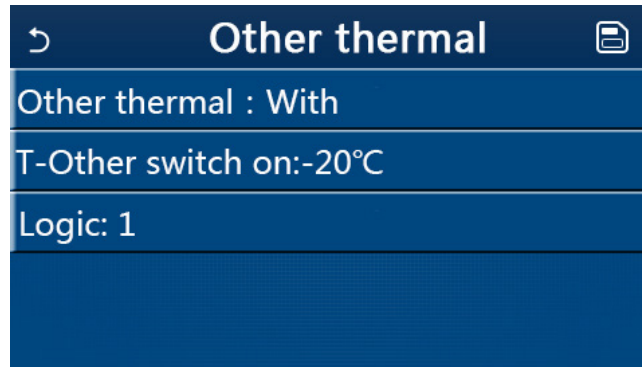

## [Notes]

- This setting will be memorized upon power failure.
- There are three working logics for it.

## Logic 1

1. The set point of other thermal should be equal to that of **“WOT-Heat”** in **“Heat”** mode and **“Heat + hot water”** mode; The set point should be the smaller one between **“T-Water tank”** +5°C and 60°C in **“Hot water”** mode.

2. The water pump for other thermal must be always active under the **“Heat”** mode.

3. Under the **“Heat”** mode, the 2-way valve will be controlled based on the setting of the control panel. During heating operation, the water pump of the heat pump unit will be stopped; however, during standby status, the water pump will start but the other thermal will stop.

Under the **“Hot water”** mode, the 3-way valve will switch to the water tank, the water pump of the heat pump will always stop but the other thermal will start.

Under the **“Heat + Hot water”** mode, the other thermal only works for space heating, and the electric heater of the water tank works for water heating. In this case, the 2-way valve is controlled based on the setting of the control panel, and the 3-way valve will always stop. During heating operation, the water pump of the heat pump unit will be stopped; however, during standby status, the water pump will start.

**Logic 2**

1. The set point of other thermal should be equal to that of **“WOT-Heat”** and both are or lower than 60°C in **“Heat”** mode and **“Heat + hot water”** mode; The set point should be the smaller one between **“T-Water tank”** +5°C and 60°C in **“Hot water”** mode.

2. The water pump for other thermal must be always active under the **“Heat”** mode.

3. Under the **“Heat”** mode, the 2-way valve will be controlled based on the setting of the control panel. During heating operation, the water pump of the heat pump unit will be stopped; however, during standby status, the water pump will start but the other thermal will stop.

Under the **“Hot water”** mode, the 3-way valve will switch to the water tank, the water pump of the heat pump will always stop but the other thermal will start.

Under the **“Heat + Hot water”** mode (**“Heat”** takes the priority), the other thermal only works for space heating, and the electric heater of the water tank works for water heating. In this case, the 2-way valve is controlled based on the setting of the control panel, and the 3-way valve will always stop. During heating operation, the water pump of the heat pump unit will be stopped; however, during standby status, the water pump will start.

Under the **“Heat + Hot water”** mode (**“Hot water”** takes the priority), the other thermal works for space heating and water heating. The other thermal will work for water heating firstly, after reached **“T-water tank”**, other thermal turns to space heating.

**Logic 3**

The heat pump will only send a signal to other thermal, but all the logic of control must be **“stand alone”**.

Other Thermal Control		
No.	Mode	Required accessories
Logic 1	Heat	RT5 temperature sensor
	Hot water	Extra 3-way valve, water tank sensor
	Heat+Hot water	RT5 temperature sensor, water tank sensor
Logic 2	Heat	RT5 temperature sensor
	Hot water	Extra 3-way valve, water tank sensor
	Heat+Hot water	Extra 3-way valve, RT5 temperature sensor, Water tank sensor
Logic 3	Heat	/
	Hot water	/
	Heat+Hot water	/

#### 4.4.7 Optional E-Heater

[Operation Instructions]

1. At the commissioning parameter setting page, by touching “**Optional E-Heater**”, the control panel will access to the corresponding setting page.

2. At the “**Optional E-Heater**” setting page, it can be set to “1”, “2” or “Off”.

3. This setting is used to compare with the ambient temperature. Different comparison results are for different status of the optional electric heater.

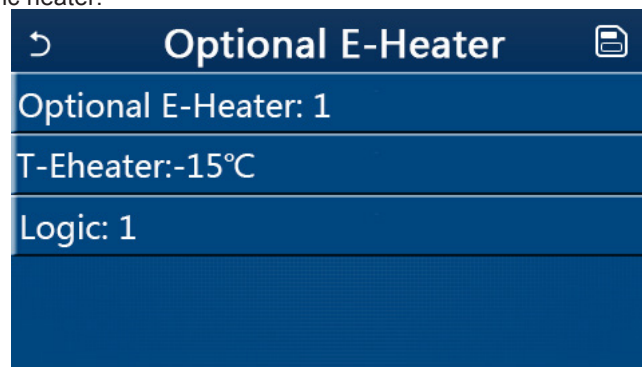

[Notes]

- This setting will be memorized upon power failure.
- Neither “**Other thermal**” or “**Optional E-Heater**” can be activated at the same time.
- There are two working logics for “**Optional E-heater**”.

Logic 1: the heat pump and the optional electric heater cannot be started at the same time.

Logic 2: the heat pump and the optional electric heater can be started at the same time when the ambient temperature is lower than T-Eheater.

- Optional E-Heater and water tank heater won't be started together.

#### 4.4.8 Remote sensor

[Operation Instructions]

At the commissioning parameter setting page, by touching “**Remote sensor**”, the control panel will access to the corresponding setting page, where it can be set to “**With**” or “**Without**”.

[Notes]

- This setting will be memorized upon power failure.
- Only when “**Remote sensor**” is set to “**With**”, the “**Ctrl. State**” can be set to “**T-room**”.

#### 4.4.9 Air removal

[Operation Instructions]

At the commissioning parameter setting page, by touching “Air removal”, the control panel will access to the corresponding setting page, where it can be set to “On” or “Off”.

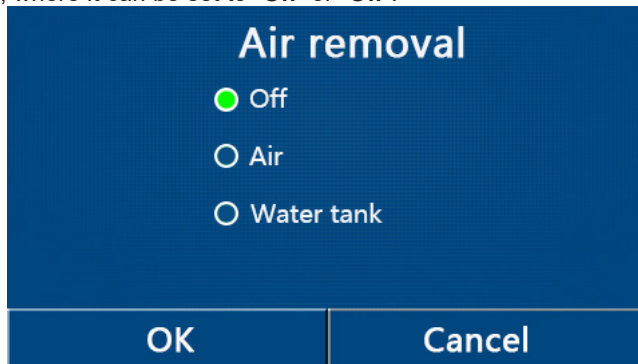

[Notes]

- This setting will be memorized upon power failure.
- This setting can be done only when the unit is turned off. And when it is set to “On”, the unit is not allowed to be turned on.

#### 4.4.10 Floor debug

[Operation Instructions]

1. At the commissioning parameter setting page, by touching “Floor debug”, the control panel will access to the corresponding setting page.

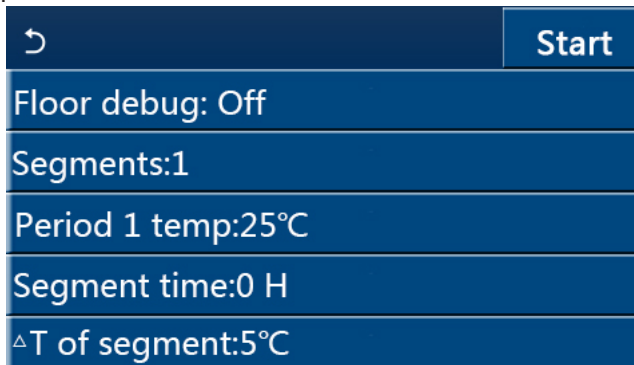

2. At the setting page, “Floor debug”, “Segments”, “Period 1 temp”, “Segment time”, and “ΔT of segment” can be set.

No.	Full Name	Displayed Name	Range	Default	Accuracy
1	Floor debug switch	Floor debug	On/Off	Off	/
2	Quantity of segments	Segments	1~10	1	1
3	Temperature of the first segment	Period 1 temp	25~35°C/ 77~95°F	25°C/ 77°F	1°C
4	Duration of each segment	Segment time	12~72 hours	0	12 hours
5	Temperature difference of each segment	ΔT of segment	2~10°C/ 36~50°F	5°C/ 41°F	1°C

3. When this setting is finished, by pressing “Start” this setting will be saved and start working, and by pressing “Stop” the function will halt.

[Notes]

- This function can be activated only when the unit is turned off. When it is done with the unit keeping “On”, a window will pop up, saying “Please turn off the system first!”.
- When this function has been activated, “On/Off” operation will be deactivated. By pressing On/Off, a window will pop up, saying “Please disable the floor debug!”.

- When “**Floor debug**” has been activated; “**Weekly timer**”, “**Clock Timer**”, “**Temp timer**” and “**Preset mode**” will be deactivated.

- “**Emergen. mode**”, “**Disinfection**”, “**Holiday mode**”, “**Manual defrost**”, “**Forced mode**” and “**Refri. recovery**” cannot be activated at the same time with “**Floor debug**”. If doing so, a window will pop up, saying “**Please disable the floor debug!**”.

- Upon power failure, “**Floor debug**” will back to “**Off**” and the runtime will be zeroed.

- When “**Floor debug**” has been activated, “T-floor debug” and “Debug time” can be viewed.

- When “**Floor debug**” has been activated and works normally; the corresponding icon will be displayed at the upper side of the menu page.

- Before activating “**Floor debug**”, make sure “**Segment time**” of each segment is not zero. If so, a window will pop up, saying “**Segment time wrong!**” In this case, “**Floor debug**” is allowed to be activated only when “**Segment time**” has changed.

#### 4.4.11 Manual defrost

[Operation Instructions]

At the commissioning parameter setting page, by touching “**Manual defrost**”, the control panel will access to the corresponding setting page.

[Notes]

- This setting will not be memorized upon power failure.

- This setting can be set only when the unit has turned off. When this function has been activated, ON operation is un-allowed.

- Defrosting will quit when the defrosting temperature goes to 20℃ or the defrosting duration is equal to 10 minutes.

#### 4.4.12 Force mode

[Operation Instructions]

1.At the commissioning parameter setting page, by touching “**Force mode**”, the control panel will access to the corresponding setting page.

2.At the “**Force mode**” setting page, it can be set to “**Force-cool**”, “**Force-heat**”, and “**Off**”. When it is set to “**Force-cool**” or “**Force-heat**”, the control panel will directly go back to the menu page and response to any touching operation except the ON/OFF operation, with a window popping up, saying “**The force-mode is running!**”. In this case, by touching ON/OFF, “**Force mode**” will quit.

[Notes]

- This function is allowed only when the unit has just repowered and not turned on. For the unit which once has been put into operation, this function is unavailable, alerting “**Wrong operation!**”.

- It will not be memorized upon power failure.

#### 4.4.13 Gate-Ctrl.

[Operation Instructions]

At the commissioning parameter setting page, by touching “**Gate-Ctrl.**”, the control panel will access to the corresponding setting page.

[Notes]

- When “**Gate-Ctrl.**” has been activated; the display panel will detect the card state. When the card has inserted, the unit will run normally. When the card is drawn out, the controller will turn off the unit at once and back to the homepage. In this case, all touching operation become ineffective, and a prompt dialog box will pop up. The unit will resume normal operation until the card has inserted back and the ON/OFF status of the control panel will resume to that before the card is drawn out.

#### 4.4.14 C/P limit (Current limit/ Power limit)

[Operation Instructions]

1. At the commissioning parameter setting page, by touching “**C/P limit**”, it can be set to “**Off**”, “**Current limit**” or “**Power limit**”.

2. When it is set to “**Off**”, current limit and power limit both cannot be set. When it is set to “**Current limit**” or “**Power limit**”, they can be set.

3. After that, this setting will be saved by touching the “**Save**” icon.

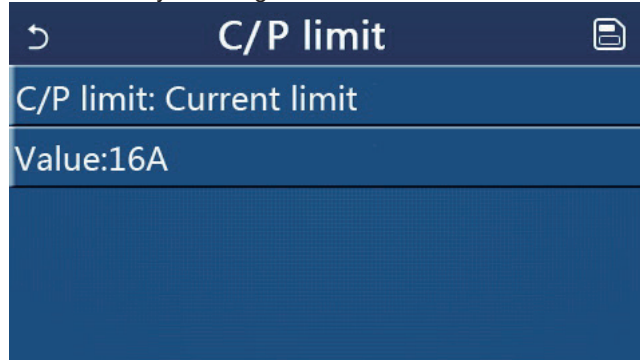

[Notes]

- This setting will be memorized upon power failure.

#### 4.4.15 Address

[Operation Instructions]

At the commissioning parameter setting page, by touching “**Address**”, it can be set the address.

[Notes]

- It is used to set the address of the control panel for being integrated to the centralized control system.
- This setting will be memorized upon power failure.
- The setting range is 1~125 and 127~253.
- The defaulted address is 1 upon first power-on.

#### 4.4.16 Refri. recovery (Refrigerant recovery)

[Operation Instructions]

At the commissioning parameter setting page, by touching “**Refri. recovery**”, it will access to the refrigerant recovery page.

When “**Refri. recovery**” is set to “**On**”, the control panel will go back to the home page. At this time, any touch operation except ON/OFF will get no response, with a prompt dialog box popping up, saying “**The refrigerant recovery is running!**” By touching ON/OFF, refrigerant recovery will quit.

[Notes]

- This function is allowed only when the unit has just repowered and not turned on. For the unit which once has been put into operation, this function is unavailable, alerting “**Wrong operation**”.
- This function will not be memorized upon power failure.

#### 4.4.17 Tank heater

[Operation Instructions]

At the commissioning parameter setting page, by touching “**Tank heater**”, it will access to the setting page of control logic for the water tank heater.

[Notes]

- “Reserved” will be displayed when the water tank is unavailable.
- This setting can be done only when the unit is off.
- This function can be memorized upon power failure.



- Logic 1: NEVER allowed the Unit's Compressor and the Water Tank Electric Heater or the Optional Electric Heater to work at the same time.

- Logic 2: While Heating/ Cooling + Hot water mode (Hot Water priority)  $T_{set} \geq THP_{max} + \Delta T_{hot\ water} + 2$ , when water tank temperature reach  $THP_{max}$ , the water tank EH will be ON and start to do hot water, at the same time, the compressor will turn to heating/cooling mode, water tank EH and Compressor will be ON together.

#### 4.4.18 Gate-Ctrl memory

[Operation Instructions]

At the commissioning parameter setting page, by touching "**Gate-Ctrl Memory**", it will access to the setting page.

[Notes]

- When it is enabled, "**Gate-Ctrl.**" will be memorized upon power failure. This setting should be done carefully. Before this function has been enabled, make sure the "Gate-ctrl" system works normally; otherwise the control panel would be locked, which then cannot be unlocked by being repowered on but be unlocked only through inserting the card.

- When it is disabled, "**Gate-Ctrl.**" will not be memorized upon power failure.

#### 4.4.19 3-Way valve1

[Operation Instructions]

At the commissioning parameter setting page, by touching "**3-Way valve1**", it will access to the setting page.

[Notes]

- It will be memorized upon power failure.

- Three options are available, "**Without**", "**DHW**", and "**AIR**". When it is set to "**AIR**", it will be closed (230VAC) under the cooling/heating mode and opened under the DHW(Hot water) mode; when it is set to "**DHW**", it will be closed (230VAC) under the DHW(Hot water) mode and opened under the cooling/heating mode.

- This setting is allowed only when the unit has been turned off.

#### 4.4.20 Hot water control mode

[Operation Instructions]

At the commissioning parameter setting page, by touching "**Hot water control mode**", it can be set to "**Auto**" or "**Manual**".

When it is set to "**Manual**", "**Running Frequency Setting**" can be set, and the user could change the parameter to fix the frequency of the compressor in the "**Hot water**" mode, otherwise, the unit will automatically run based on the original logic.

After that, this setting will be saved by touching the "**Save**" icon.

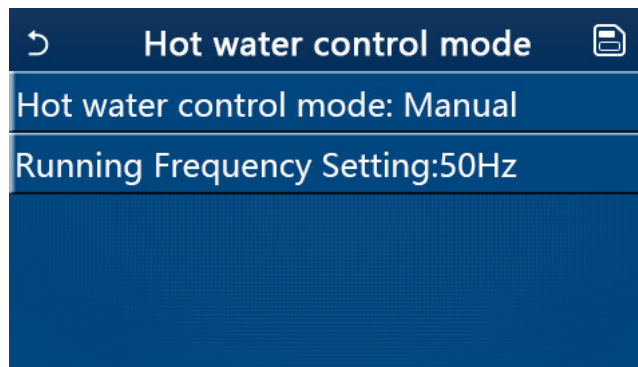

[Notes]

- This setting will be memorized upon power failure.



**4.4.21 Parameter setting**

[Operation Instructions]

At the commissioning parameter setting page, by touching “PARAM.”, it will access to the pages as shown below.

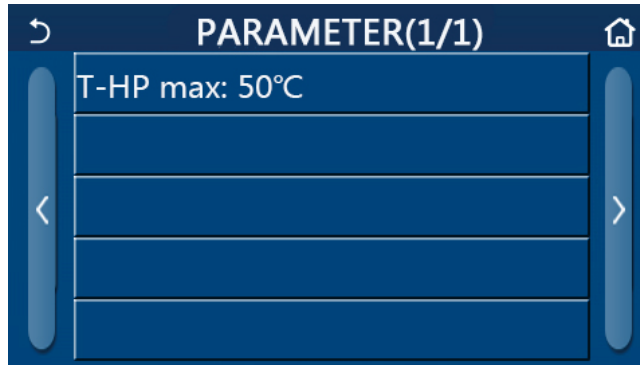

Page of Commissioning Parameters

At this page, select the desired option and then go to the corresponding page.

After that, by pressing “OK”, this setting will be saved and then the unit will run based on this setting; or by pressing “Cancel”, this setting will not be saved and quit.

No.	Full Name	Display Name	Range		Default	Remark
1	T-HP max	T-HP max	40~55°C	104~131°F	50°C/122°F	/

[Notes]

- For parameters with different defaults at different conditions, once the current condition changes, the corresponding default also will change.

- All parameters at this page will be memorized upon power failure.

**4.5 Viewing**

[Operation Instructions]

1.At the menu page, by touching “VIEW”, the control panel will go to the sub-menu page as shown in the figure below.

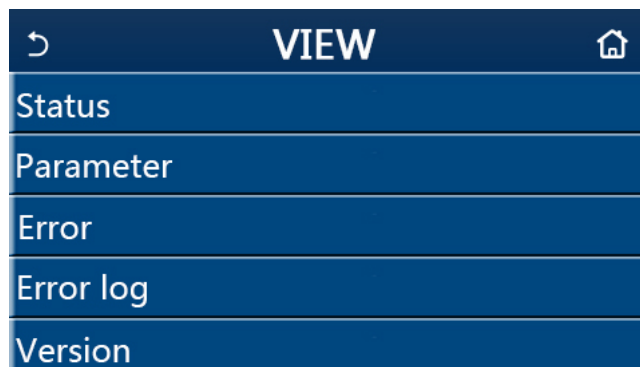

VIEW Page

**4.5.1 Status**

[Operation Instructions]

1.At the “VIEW” page, by touching “Status”, it is able to view status of the unit, as shown in the figure below.

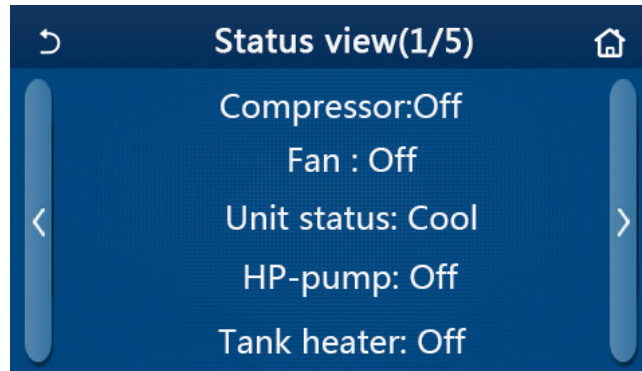

Status View Page  
Viewable Status

No.	Full Name	Displayed Name	Status	Remarks
1	Status of the compressor	Compressor	On/Off	/
2	Status of the fan	Fan	On/Off	/
3	Status of the unit	Unit status	Cool/Heat/Hot water/Off	"Cool" is unavailable to the heating only unit.
4	Status of the water pump	HP-pump	On/Off	/
5	Status of the water tank heater	Tank heater	On/Off	/
6	Status of the 3-way valve 1	3-way valve 1	NA	/
7	Status of the 3-way valve 2	3-way valve 2	On/Off	/
8	Status of the compressor crankcase heater	Crankc. heater	On/Off	/
9	Status of the heater 1 for the main unit	HP-heater 1	On/Off	/
10	Status of the heater 2 for the main unit	HP-heater 2	On/Off	/
11	Status of the Chassis heater	Chassis heater	On/Off	/
12	Status of the heat exchanger heater	Plate heater	On/Off	/
13	Status for the system defrosting	Defrost	On/Off	/
14	Status of the system oil return	Oil return	On/Off	/
15	Status of the thermostat	Thermostat	Off/Cool/Heat/Hot water/Cool+hot water/Heat+hot water	"Cool" is unavailable to the heating only unit.
16	Status of other thermal source	Other thermal	On/Off	/
17	Status of the 2-way valve	2-way valve	On/Off	/
18	Status of antifreeze	HP-Antifree	On/Off	/
19	Status of the door guard	Gate-Ctrl.	Card in/Card out	/
20	Status of the 4-way valve	4-way valve	On/Off	/
21	Status of disinfection	Disinfection	Off/Running/Done/Fail	/
22	Status of the flow switch	Flow switch	On/Off	/
23	Status of the tank pump	Tank pump	On/Off	/

#### 4.5.2 Parameter

[Operation Instructions]

1. At the "VIEW" page, by touching "Parameter", it is able to view each parameter of the unit, as shown in the figure below.

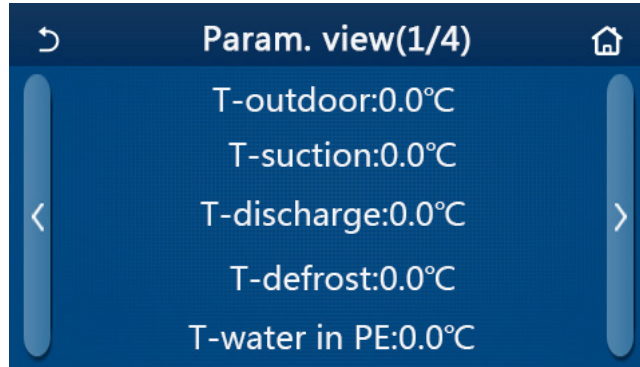

Parameter View Page  
Viewable Parameters

No.	Full Name	Displayed Name	Remarks
1	Environmental temperature	T-outdoor	/
2	Suction temperature	T-suction	/
3	Discharge temperature	T-discharge	/
4	Defrosting temperature	T-defrost	/
5	Entering water temperature of the plate type heat exchanger	T-water in PE	/
6	Leaving water temperature of the plate type heat exchanger	T-water out PE	/
7	Leaving water temperature of the auxiliary heater	T-optional water Sen.	/
8	Water tank temperature	T-tank ctrl.	/
9	Floor debug target temperature	T-floor debug	/
10	Floor debug runtime	Debug time	/
11	Liquid line temperature	T-liquid pipe	/
12	Vapor line temperature	T-gas pipe	/
13	Economizer inlet temperature	T-economizer in	/
14	Economizer outlet temperature	T-economizer out	/
15	Remote room temperature	T-remote room	/
16	Discharge pressure	Dis. pressure	/
17	Weather-dependent target temperature	T-weather depend	/

#### 4.5.3 Error

[Operation Instructions]

At the “VIEW” page, by touching “Error”, it is able to view errors of the unit, as shown in the figure below.

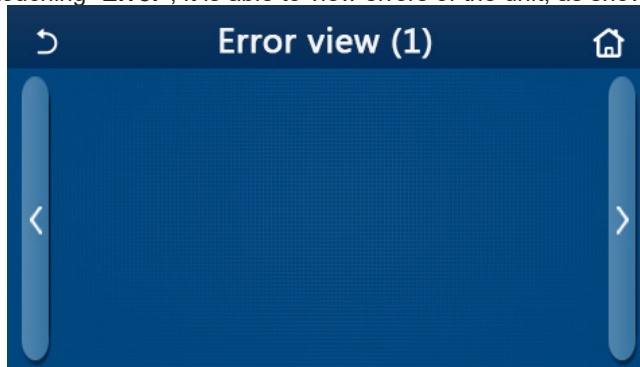

Error View Page

[Notes]

- The control panel can display real-time errors. And at these pages, all errors will be listed here.
- Each page displays at most 5 pieces of errors. Others can be viewed by touching the page turning keys.

#### Error List

No.	Full Name	Displayed Name
1	Ambient temperature sensor error	Ambient sensor
2	Defrosting temperature sensor error	Defrost sensor
3	Discharge temperature sensor error	Discharge sensor
4	Suction temperature sensor error	Suction sensor
5	Economizer inlet temperature sensor	Econ. in sens.
6	Economizer outlet temperature sensor	Econ. out sens.
7	Fan error	Outdoor fan
8	High pressure protection	High pressure
9	Low pressure protection	Low pressure
10	High discharge protection	Hi-discharge
11	Capacity DIP switch error	Capacity DIP
12	Communication error between the outdoor and indoor main boards	ODU-IDU Com.
13	Communication error between the outdoor main board and the drive board	Drive-main com.
14	Communication error between the display panel and indoor main board	IDU Com.
15	High pressure sensor error	HI-pre. sens.
16	Leaving water temperature sensor error for the plate type heat exchanger of the heat pump	Temp-HELW
17	Leaving water temperature sensor error for the auxiliary electric heat of the heat pump	Temp-AHLW
18	Entering water temperature sensor error of the plate type heat exchanger of the heat pump	Temp-HEEW
19	Water tank temperature sensor error	Tank sens.
20	Remote room temperature sensor error	T-Remote Air
21	Protection for the flow switch of the heat pump	HP-Water Switch
22	Welding protection to the auxiliary electric heater 1 of the heat pump	Auxi. heater 1
23	Welding protection to the auxiliary electric heater 2 of the heat pump	Auxi. heater 2
24	Welding protection to the water tank electric heater	Auxi. -WTH
25	DC bus under-voltage or voltage drop error	DC under-vol.
26	DC bus over-voltage	DC over-vol.
27	AC current protection (input side)	AC curr. pro.
28	IPM defective	IPM defective
29	PFC defective	PFC defective
30	Start failure	Start failure
31	Phase loss	Phase loss
32	Jumper cap error	Jumper cap error
33	Driver resetting	Driver reset
34	Compressor overcurrent	Com. over-cur.
35	Current sensing circuit error or current sensor error	Current sen.
36	Desynchronization	Desynchronize
37	Radiator or IPM or PFC over-temperature	Overtemp.-mod.
38	Radiator or IPM or PFC temperature sensor error	T-mod. sensor
39	Charging circuit error	Charge circuit

No.	Full Name	Displayed Name
40	AC input voltage error	AC voltage
41	Sensor connection protection ( the current sensor fails to be connected with the corresponding phase U and or phase V)	Sensor con.
42	Communication error between the display panel and the outdoor unit	ODU Com.
43	Refrigerant vapor line temperature sensor error	Temp RGL
44	Refrigerant liquid line temperature sensor error	Temp RLL
45	4-way valve error	4-way valve

#### 4.5.4 Error log

[Operation Instructions]

At the “**VIEW**” page, by touching “**Error log**”, the control panel will go to the error log page, where it is able to view error records.

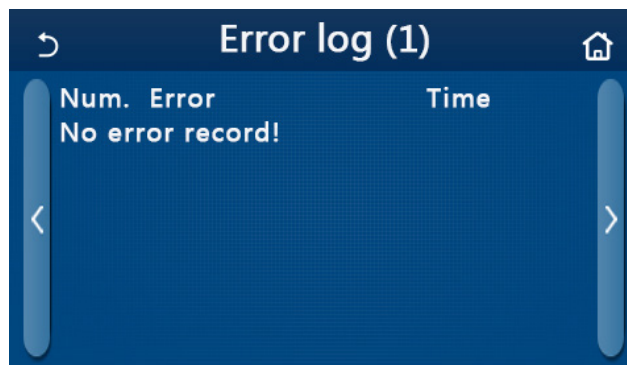

[Notes]:

- The error log can accommodate up to 20 pieces of error. Name and occurrence time are available for each error.
- When error log exceeds 20, the latest will supersede the earliest.

#### 4.5.5 Version

[Operation Instructions]

At the “**VIEW**” page, by touching “**Versioin**”, the control panel will go to the version view page, where it is able to view both the program version and protocol version.

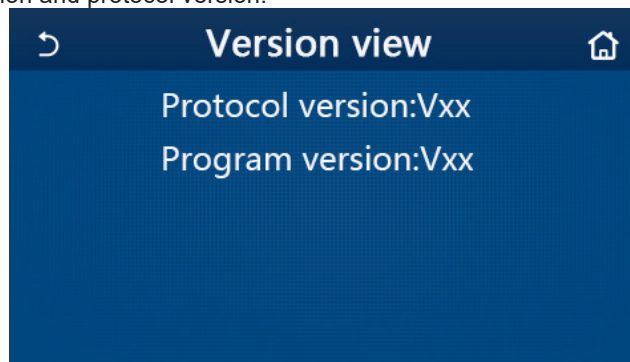

### 4.6 General Setting

[Operation Instructions]

1. At the menu page, by touching “**GENERAL**”, the control panel will go to the setting page, as shown in the figure below, where it is able to set “**Temp.unit**”, “**On/off memory**”, “**Beeper**”, “**Back light**”, “**Time & Date**” and “**Language**”.

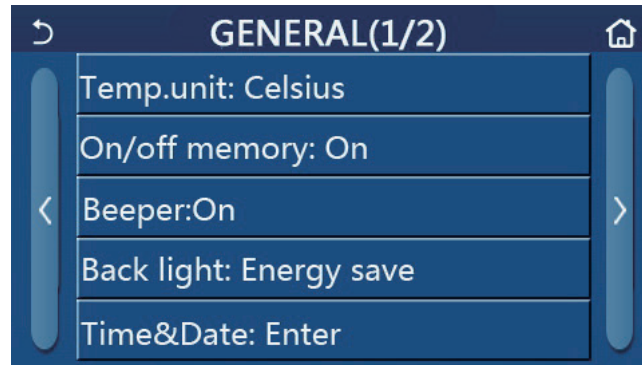

General Setting Page  
General Settings

No.	Item	Range	Default	Remarks
1	Temp. unit	°C/°F	°C	/
2	On/Off memory	On/Off	On	/
3	Beeper	Enter	On	/
4	Back light	Lighted/Energy save	Energy save	<p>“<b>Lighted</b>”: the control panel will always light on.</p> <p>“<b>Energy save</b>”: When there is no touching operation in 5 minutes, the control panel will be lighted off automatically, but will light on again once there is any touching operation.</p>
5	Time&Data	Enter	/	/
6	Language	Italiano/English/Español/ Nederlands/Français/Deutsch/ Български/PolSKI/Suomi/Svenska/ Türkçe/Magyar/Lietuvių/Hrvatski/ Čeština/Srpski/Angleški/...	English	/
7	WiFi	On/Off	On	/

#### 4.6.1 Time and clock

[Operation Instructions]

1. At the “GENERAL” setting page, by touching “Time&Data”, it will go to the setting page as shown in the figure below.

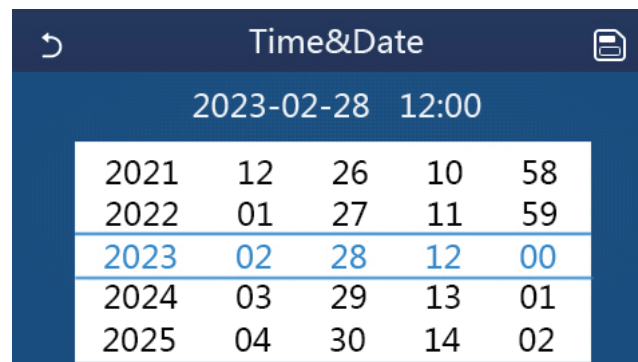

Time&Data Page

2. The mouse roller can change the date and time value. After it, by touching the “Save” icon, this setting will be saved and directly displayed; while by touching the “Back” icon, this setting will give up and the control panel will directly go back to the “GENERAL” setting page.

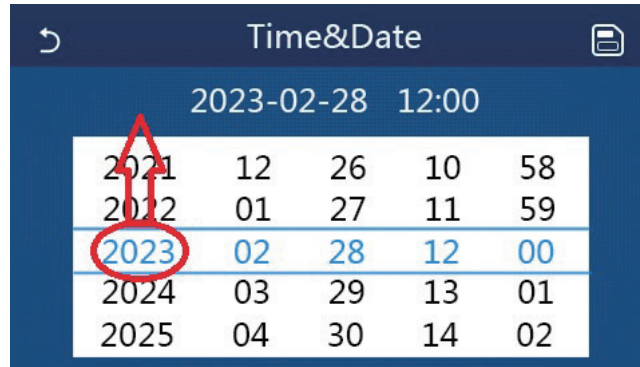

Time&amp;Data Page

## 5 Intelligent Control

As shown in the figure below, remote control via a smart phone is available for the control panel.

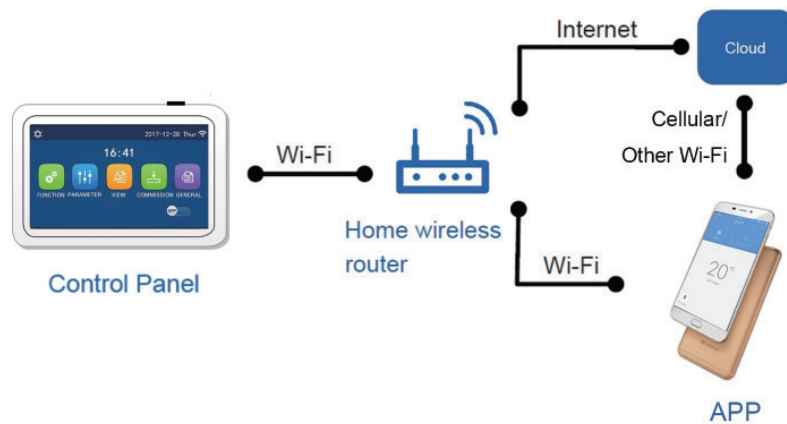

[Notes]:

- Make sure the smart phone or tablet computer adopts standard Android or ios operation system. For detailed version, please refer to the APP.
- The Wi-Fi function doesn't support Chinese Wi-Fi network name.
- The devices can be connected and controlled only in Wi-Fi and 4G hotspot modes.
- Software operation interface is universal and its control functions may not be completely corresponding to the unit. Software operation interface may vary along with APP upgrading or different operation system. Please refer to the actual program.

### 5.1 Install KINGHOME+ APP

[Operation Instructions]

1.Scan the following QR code with your smart phone to download and install KINGHOME+ APP directly.



2.Open KINGHOME+ APP and click “Sign up” for registration.

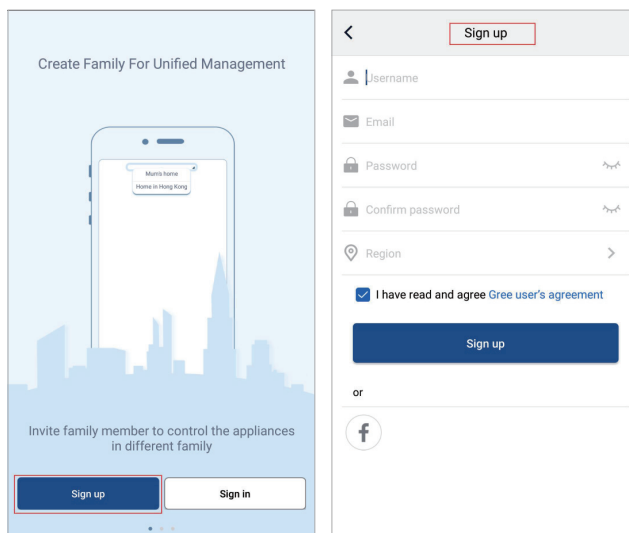

3.Except sign in in the prompt interface, you can also enter the homepage and click the profile picture at the left upper corner to sign in.

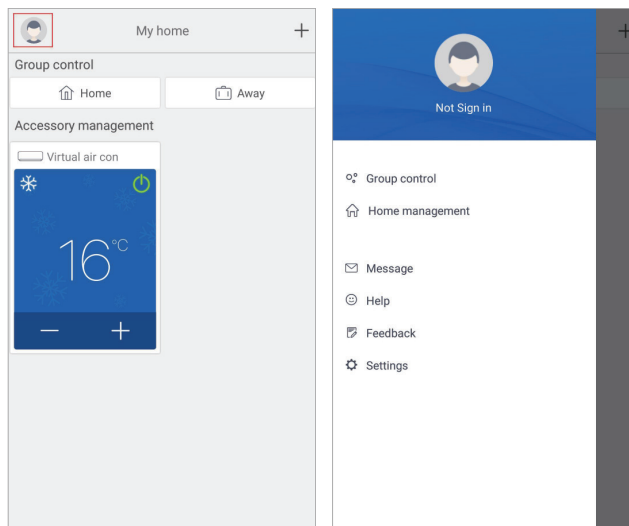



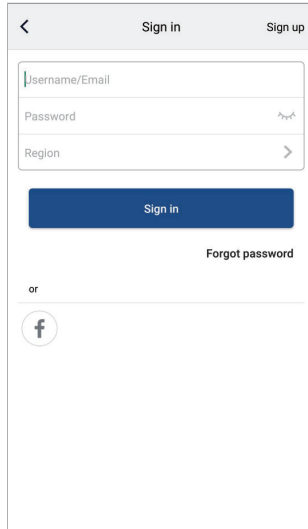

4. Click "+" at the right upper corner of homepage to add device.

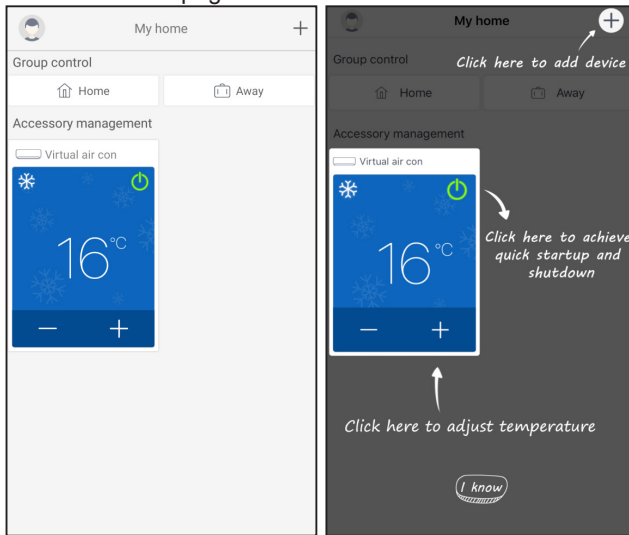

(1) Automatically search the nearby devices

Automatically search for nearby devices. When a device that can be connected to the network is found nearby, the icon of the device that can be connected to the network will be displayed at the top of the page. Click the icon of the discovered device, and then follow the instructions on the page to confirm the home WiFi (enter the home WiFi and password), click The next step is to wait for the network configuration to complete.

(Note: Only devices that support Bluetooth flash matching can be connected to the network by automatically discovering nearby devices. For devices that do not support Bluetooth flash matching, please refer to [(2) Select devices by category])

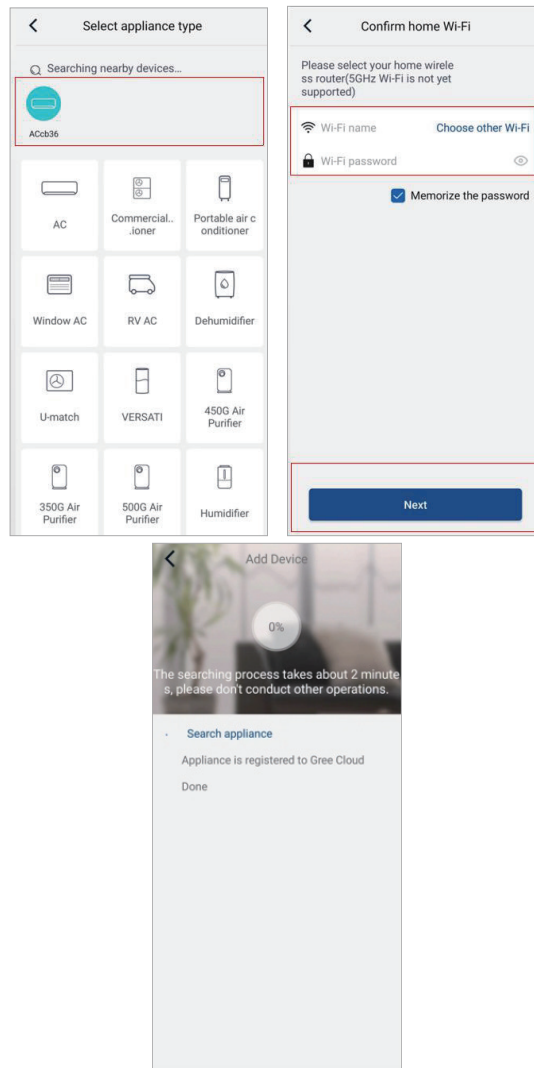

(2) Add devices by select appliance type

If automatically search fails to find the nearby devices, please choose to add devices by selecting the appliance type, and click the type of the device to be added.

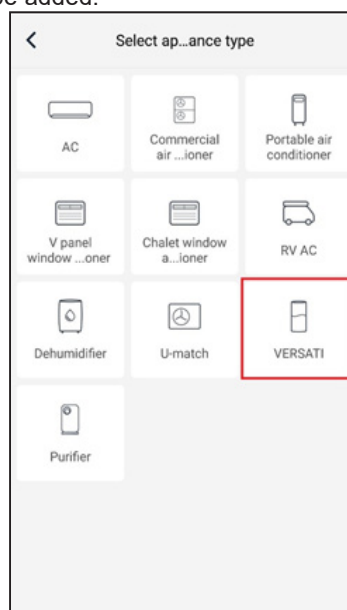

After selecting "VERSATI", the APP interface will provide relevant operation instructions.

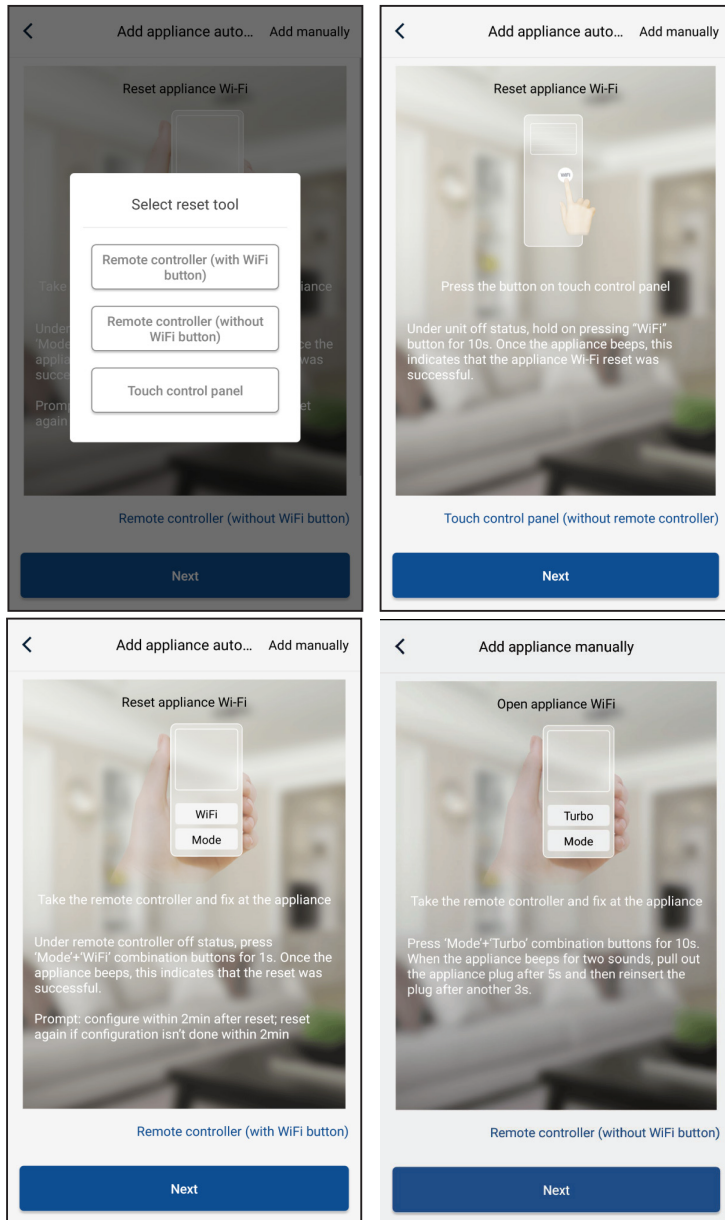

Reset the air conditioner (refer to the operation instructions in APP interface) and click **“Next”** to add home appliance automatically (Wi-Fi password shall be input). Or after setting and energizing the air conditioner, click **“Add appliance manually”** at the right upper corner to select the wireless network for controlling the device. Then confirm family Wi-Fi and arrange configuration.

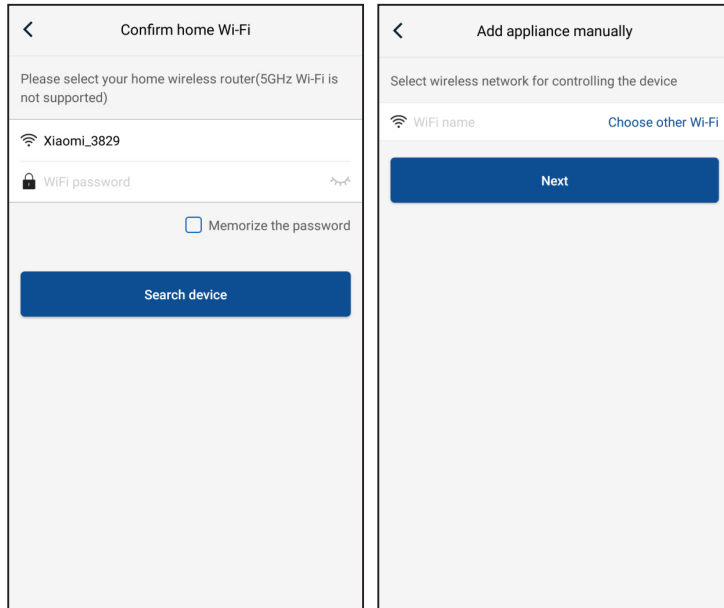

After accomplishing device reset and filling correct information, search device and arrange configuration.

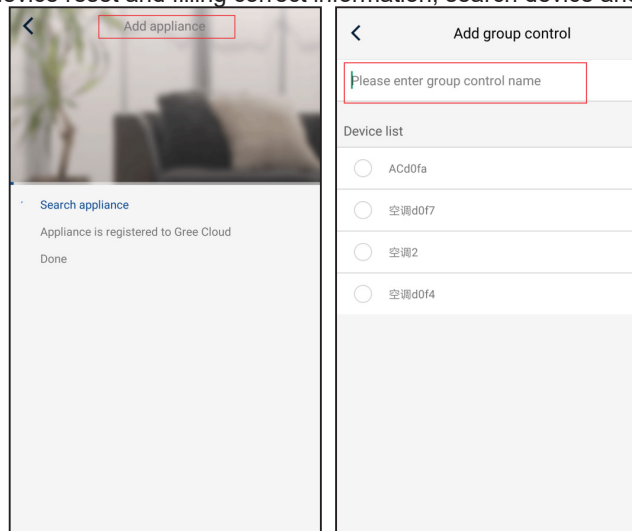

## 5.2 Setting of Other Functions

Click the profile picture at the left upper corner of homepage and set each function in the following menu.

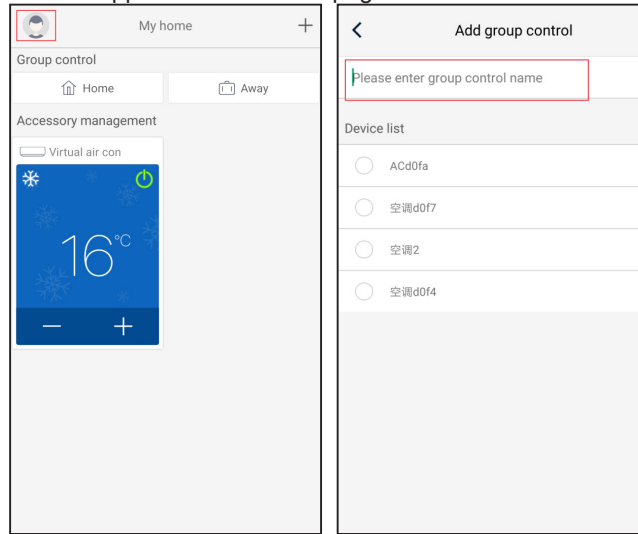

### 5.2.1 Home management

Click “Home management” to create or manage family. You can also add family members according to the registered account.

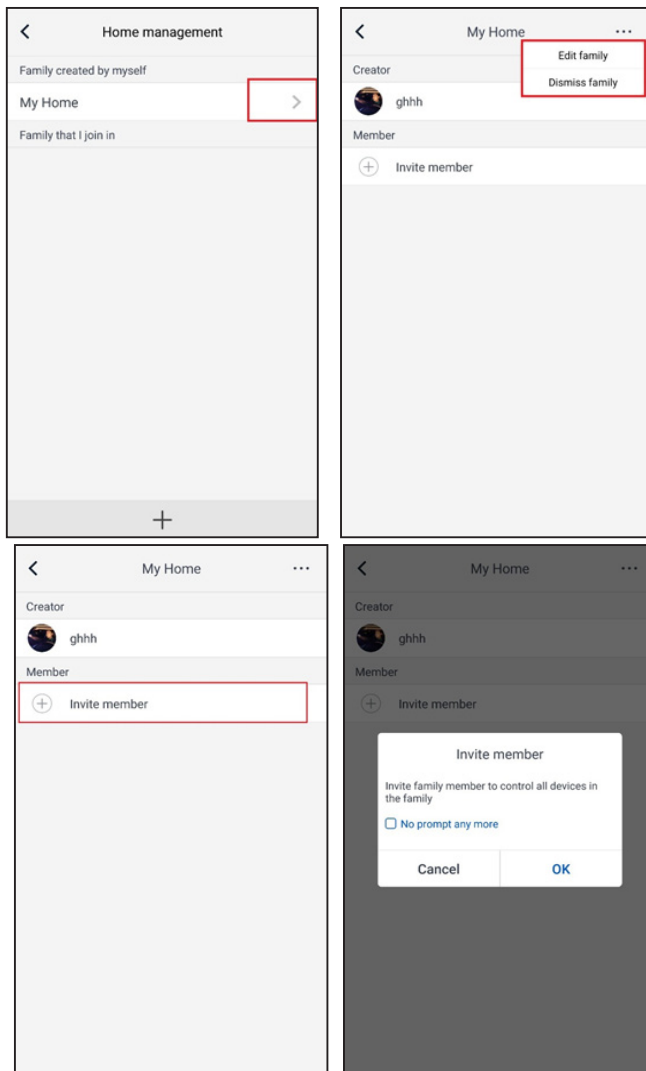

### 5.2.2 Help

Click "Help" and view the operation instructions of the APP.

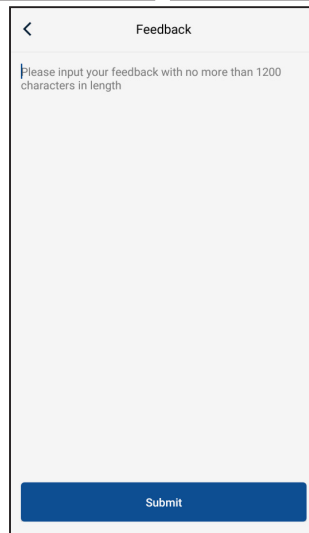
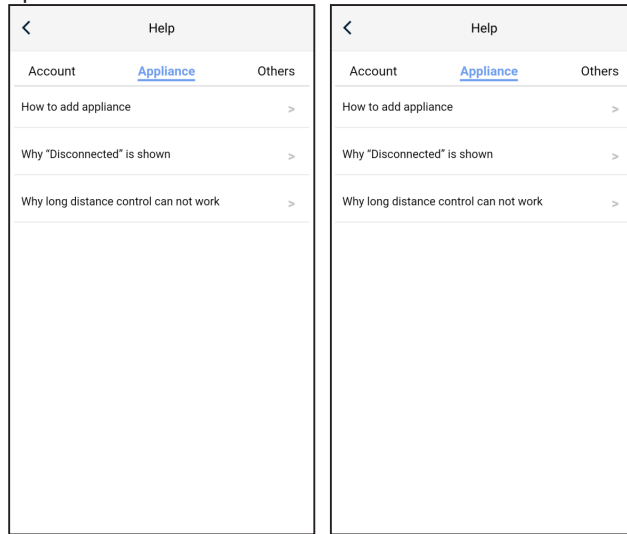

### 5.3 Feedback

Click "Feedback" to submit feedback.

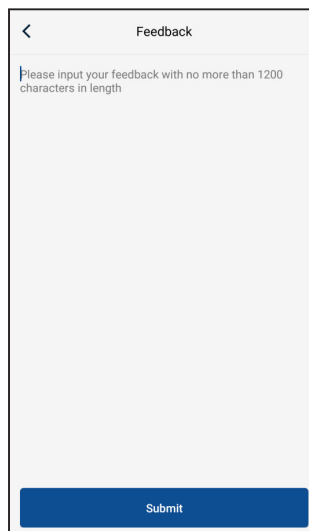

## UNIT INSTALLATION

### 1 Installation Guides

#### (1) General requirements

#### WARNING

Design and installation work of the unit must be performed by authorized personnel according to applicable laws and regulations and this Instruction.

After installation work, the unit cannot be energized unless there is not any problem in check.

If the supply cord is damaged, it must be replaced by the manufacturer, its service agent or similarly qualified persons in order to avoid a hazard.

This product is a kind of comfort air conditioning, and is not allowed to be installed where there are corrosive, explosive and inflammable substances or smog; otherwise it would lead to operation failure, shortened service life, five hazard or even severe injuries. Special air conditions are required for where mentioned above.

Before installation, please see if the voltage of local place accords with that on nameplate of unit and capacity of power supply, power cord or socket is suitable for input power of this unit.

Before installation, please check if the adopted power is accordance with that listed on nameplate, and check the safety of power.

Before using, please check and confirm if wires and water pipes are connected correctly to avoid water leakage, electric shock or fire etc.

Don't operate the unit with wet hand, and don't allow children to operate the unit.

The water in unit and pipeline should be discharged if the unit is not in use, to prevent the water tank, pipe line and water pump from frost-cracking.

#### CAUTION

After receipt of the unit, check it for appearance, unit model compared with your desire and attachments.

Ensure periodical clean and maintenance of the unit after normal operation of the unit for longer life and reliable operation.

The appliance shall be installed in accordance with local wiring regulations.

To realize the function of the air conditioner unit, a special refrigerant circulates in the system. The used refrigerant is the fluoride R32, which is specially cleaned. The refrigerant is flammable and inodorous. Furthermore, it can leads to explosion under certain conditions. But the flammability of the refrigerant is very low. It can be ignited only by fire.

Compared to common refrigerants, R32 is a nonpolluting refrigerant with no harm to the ozonosphere. The influence upon the greenhouse effect is also lower. R32 has got very good thermodynamic features which lead to a really high energy efficiency. The units therefore need a less filling.

If there is any question, please contact with local dealer, authorized service center, agencies or our company directly.

#### (2) Special requirements

#### WARNING

Do not use means to accelerate the defrosting process or to clean, other than those recommended by the manufacturer. Should repair be necessary, contact your nearest authorized service centre. Any repairs carried out by unqualified personnel may be dangerous. The appliance shall be stored in a room without continuous operating ignition sources. (for example: open flames, an operating gas appliance or an operating electric heater.) Do not pierce or burn.

Appliance filled with flammable gas R32. For repairs, strictly follow manufacturer's instructions only. Be aware that refrigerants not contain odour.

If a stationary appliance is not fitted with a supply cord and a plug, or with other means for disconnection from the supply mains having a contact separation in all poles that provides full disconnection under overvoltage category III conditions, the instructions shall state that means for disconnection must be incorporated in the fixed wiring in accordance with the wiring rules.

Piping material, pipe routing, and installation shall include protection from physical damage in operation and service, and be in compliance with national and local codes and standards, such as ASHRAE 15, IAPMO Uniform Mechanical Code, ICC International Mechanical Code, or CSA B52. All field joints shall be accessible for inspection prior to being covered or enclosed.

The installation of pipe-work shall be kept to a minimum.

Protection devices, piping, and fittings shall be protected as far as possible against adverse environmental effects, for example, the danger of water collecting and freezing in relief pipes or the accumulation of dirt and debris.

Steel pipes and components shall be protected against corrosion with a rustproof coating before applying any insulation.

Solenoid valves shall be correctly positioned in the piping to avoid hydraulic shock.

Solenoid valves shall not block in liquid refrigerant unless adequate relief is provided to the refrigerant system low pressure side.

Flexible pipe elements shall be protected against mechanical damage, excessive stress by torsion, or other forces. They should be checked for mechanical damage annually.

The indoor equipment and pipes shall be securely mounted and guarded such that accidental rupture of equipment cannot occur from such events as moving furniture or reconstruction activities.



**⚠ CAUTION**

The range of external static pressures at which the appliance was tested (add-on heat pumps, and appliances with supplementary heaters, only);

The appliance is intended to be permanently connected to the water mains and not connected by a hose-set.

Precautions shall be taken to avoid excessive vibration or pulsation

Keep any required ventilation openings clear of obstruction.

Maximum and minimum water operating temperatures

Item	Minimum water operating temperatures	Maximum water operating temperatures
Cooling	5°C	25°C
Heating	20°C	65°C
Water heating	40°C	80°C

The leaving water temperature varies at different environment. 65°C is the highest leaving water temperature at 10-20°C ambient temperature.

When the electric heater for the water tank prepared by the user themselves has been activated, the leaving water temperature can go up to 80°C.

Maximum and minimum water operating pressures

Item	Minimum water operating pressures	Maximum water operating pressures
Cooling	0.05MPa	0.25MPa
Heating		
Water heating		

Maximum and minimum entering water pressures.

Item	Minimum entering water pressures	Maximum entering water pressures
Cooling	0.05MPa	0.25MPa
Heating		
Water heating		

**(3) Spaces for refrigerant pipes**

1) For the Monobloc type unit, it shall be installed in a well-ventilated area.

2) For the split-type unit, points below shall be followed.

Compliance with national gas regulations shall be observed;

Refrigerant charging valves shall be accessible for maintenance purposes;

For appliances containing FLAMMABLE REFRIGERANTS, the minimum floor area of the room shall be mentioned in the table below. When the floor area for installation is less than 1.2m<sup>2</sup>, the unit shall be installed where is well ventilated.

Minimum room area (m <sup>2</sup> )	Charge amount(kg)	≤1.2	1.3	1.4	1.5	1.6	1.7	1.8	1.9	2	2.1	2.2	2.3	2.4	2.5
	floor location	/	14.5	16.8	19.3	22	24.8	27.8	31	34.3	37.8	41.5	45.4	49.4	53.6
	window mounted	/	5.2	6.1	7	7.9	8.9	10	11.2	12.4	13.6	15	16.3	17.8	19.3
	wall mounted	/	1.6	1.9	2.1	2.4	2.8	3.1	3.4	3.8	4.2	4.6	5	5.5	6
	ceiling mounted	/	1.1	1.3	1.4	1.6	1.8	2.1	2.3	2.6	2.8	3.1	3.4	3.7	4

**(4) Unventilated area**

An unventilated area where the appliance using FLAMMABLE REFRIGERANTS is installed shall be so constructed that should any refrigerant leak, it will not stagnate so as to create a fire or explosion hazard.

The appliance shall be stored in a well-ventilated area.

The appliance shall be stored in a room without continuously operating open flames (for example an operating gas appliance) and ignition sources (for example an operating electric heater).

The appliance shall be stored so as to prevent mechanical damage from occurring.

**(5) Qualification of workers**

Any person who is involved with working on or breaking into a refrigerant circuit should hold a current valid certificate from an industry-accredited assessment authority, which authorises their competence to handle refrigerants safely in accordance with an industry recognised assessment specification.

Servicing shall only be performed as recommended by the equipment manufacturer. Maintenance and repair requiring the assistance of other skilled personnel shall be carried out under the supervision of the person competent in the use of flammable refrigerants.

**(6) Safety operation of flammable refrigerant**

**Qualification requirement for installation and maintenance**

All the work men who are engaging in the refrigeration system should bear the valid certification awarded by the authoritative organization and the qualification for dealing with the refrigeration system recognized by this industry. If it needs other technician to maintain and repair the appliance, they should be supervised by the person who bears the qualification for using the flammable refrigerant.

It can only be repaired by the method suggested by the equipment's manufacturer.

**Installation notes**

The unit is not allowed to use in a room that has running fire (such as fire source, working coal gas ware, operating heater).

It is not allowed to drill hole or burn the connection pipe.

The unit must be installed in a room that is larger than the minimum room area. The minimum room area is shown on the nameplate or the table above.

A leak test is a must after installation.

**Maintenance notes**

Check whether the maintenance area or the room area meet the requirement.

- It's only allowed to be operated in the rooms that meet the requirement.

Check whether the maintenance area is well-ventilated.

- The continuous ventilation status should be kept during the operation process.

Check whether there is fire source or potential fire source in the maintenance area.

- The naked flame is prohibited in the maintenance area; and the "no smoking" warning board should be hanged. nameplate.

Check whether the appliance mark is in good condition.

- Replace the vague or damaged warning mark.

**Welding**

If you should cut or weld the refrigerant system pipes in the process of maintaining, please follow the steps as below:

- a. Shut down the unit and cut power supply
- b. Eliminate the refrigerant
- c. Vacuuming
- d. Clean it with N<sub>2</sub> gas

- e. Cutting or welding
- f. Carry back to the service spot for welding

The refrigerant should be recycled into the specialized storage tank.

Make sure that there isn't any naked flame near the outlet of the vacuum pump and it's well-ventilated.

**Filling the refrigerant**

Use the refrigerant filling appliances specialized for R32. Make sure that different kinds of refrigerant won't contaminate with each other.

The refrigerant tank should be kept upright at the time of filling refrigerant.

Stick the label on the system after filling is finished (or haven't finished).

Don't overfilling.

After filling is finished, please do the leakage detection before test running; another time of leak detection should be done when it's removed.





**Safety instructions for transportation and storage**



Please use the flammable gas detector to check before unload and open the container.

No fire source and smoking.



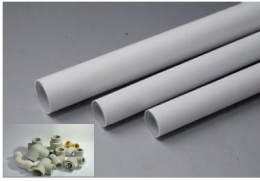

Do comply with the local rules and laws.

**2 Field Supplied Pipes and Valves**

Name	Picture	Usage
Water Filter		It is used to remove foreign matters in the waterway.
2-way Valve		It is used to switch waterways between underfloor system and the FCU.
3-way Valve		It is used to switch waterways of hot water inside the water tank and circulation water inside the main unit.
Bypass Valve		It is used to balance the water pressure.

Name	Picture	Usage
Water manifold		It is used to distribute water.
Pipe and Pipe Joint		It is used to connect the water pipes.
Cut-off Valve		It is used to cut off or get through the waterway.

### 3 Service Tools

Name	Picture
Spanner	
Screw Driver	
Pliers	
Tube Tong	

## 4 Installation Instructions

### 4.1 Installation Examples

#### CASE 1: Connecting Under-floor Coil for Heating and Cooling

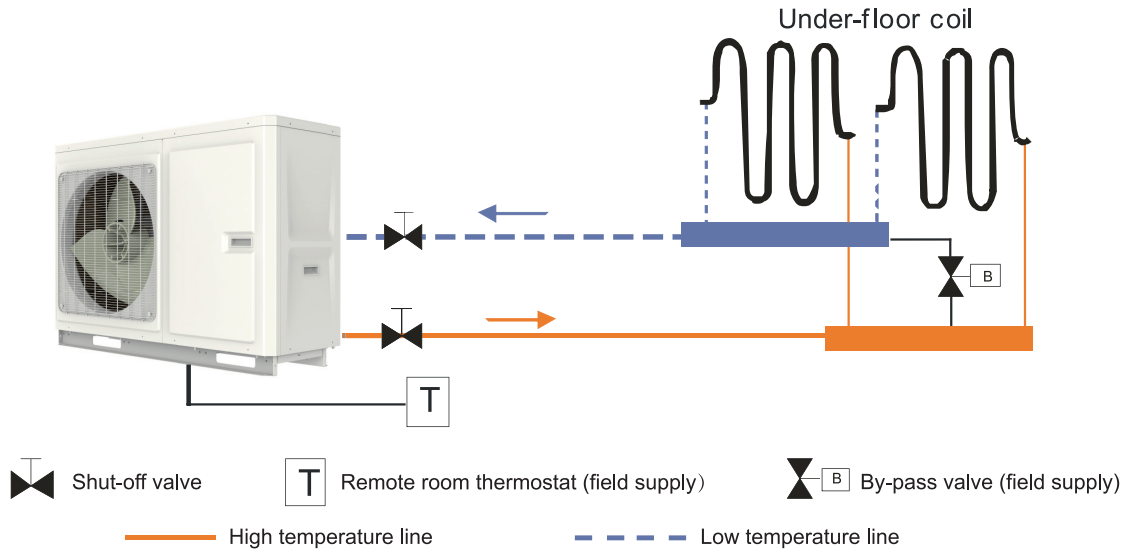

#### Notes

- (a) Type of thermostat and specification should be complied with installation of this manual;
- (b) Bypass valve must be installed to secure enough water flow rate, and bypass valve should be installed at the collector.

#### CASE 2: Connecting Sanitary Water Tank and Under-floor Coil

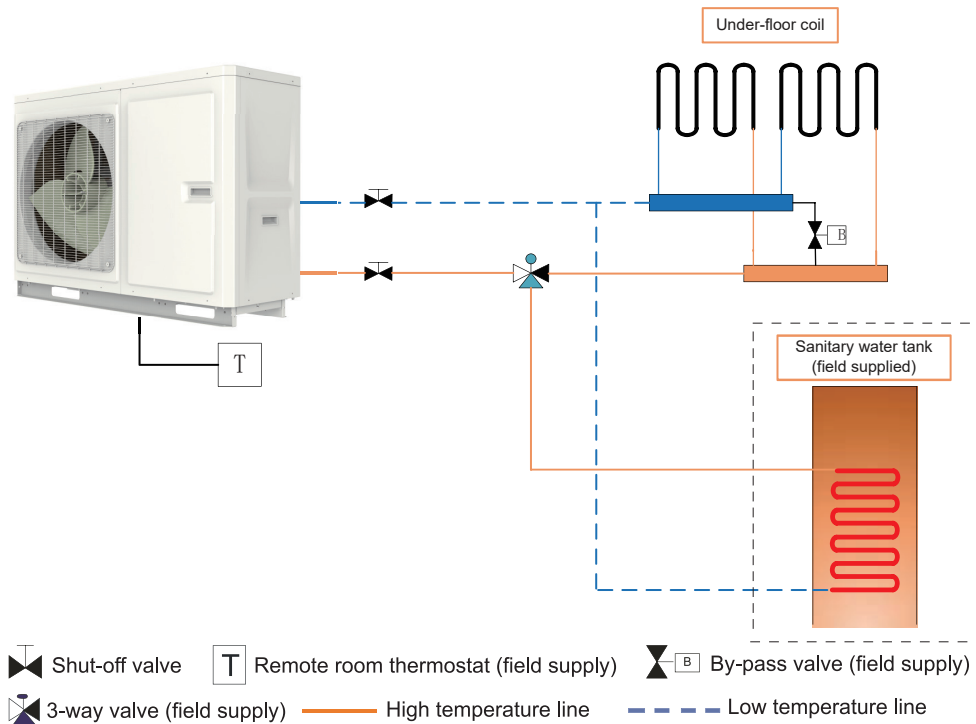

#### Notes

- (a) In this case, three-way valve should be installed and should be complied with installation of this manual;
- (b) Sanitary should be equipped with internal electric heater to to secure enough heat energy in the very cold days.
- (c) Water inside the main unit is not allowed to be connected to potable water or sanitary water.
- (d) If the water tank is required, the heat exchanger of the water tank should be double-walled and make sure the unit operate normally.

**CASE 3 : Connecting Sanitary Water Tank, Under-floor Coil and FCU**

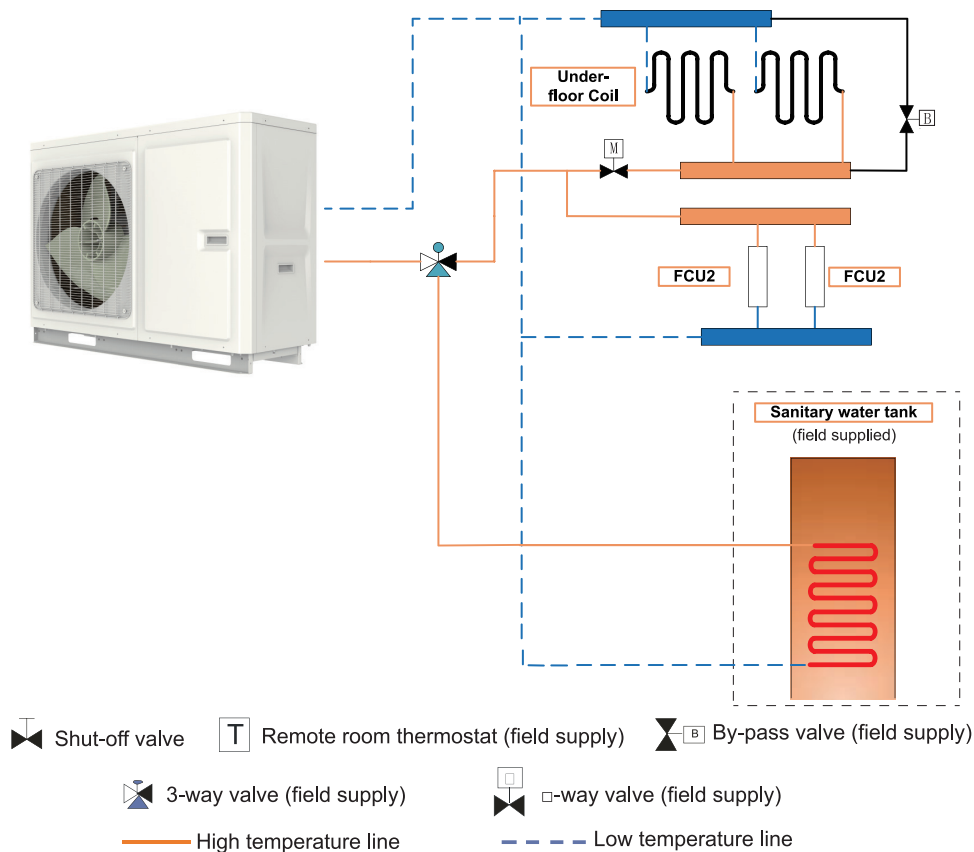

**Notes**

- (a) Two-way valve is very important to prevent dew condensation on the floor and Radiator while cooling mode.
- (b) Water inside the main unit is not allowed to be connected to potable water or sanitary water.
- (c) If the water tank is required, the heat exchanger of the water tank should be double-walled and make sure the unit operate normally.

**4.2 Pre-Installation**

- (1) Installation of the unit must be in accordance with national and local safety codes.
- (2) Installation quality will directly affect the normal use of the air conditioner unit. The user is prohibited from installation. Please contact your dealer after buying this machine. Professional installation workers will provide installation and test services according to installation manual.
- (3) Do not connect the unit to the electric power until all installation work is completed.
- (4) When moving the unit, it is necessary to adopt 2 pieces of long enough rope to hand the unit from 4 directions. Included angle between the rope when lifting and moving must be or less than 40° to prevent center of the unit from moving.
- (5) Adopt M12 bolts components to tighten feet and underframe when installing.
- (6) The unit should be installed on the concrete base that is 10cm high.
- (7) The unit must be lifted by using designated lifting holes. Take care to protect the unit during lift.
- (8) To avoid rusting, do not knock the metal parts.
- (9) For appliances with SUPPLEMENTARY HEATERS, the minimum CLEARANCE from the appliance to combustible surfaces is 500mm.

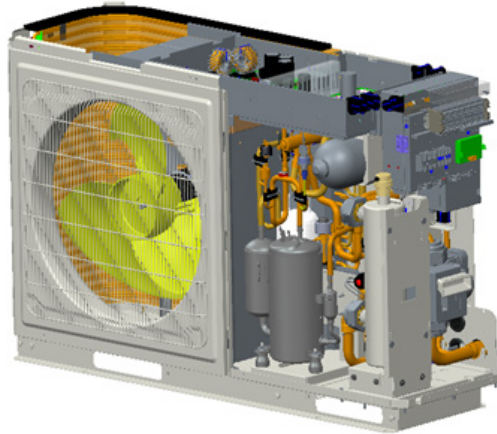

### 4.3 Selection of Installation Location

- (1) Monobloc unit must be installed on a firm and solid support.
- (2) Avoid placing the monobloc unit under window or between two constructions, hence to prevent normal operating noise from entering the room.
- (3) Air flow at inlet and outlet shall not be blocked.
- (4) Install at a well-ventilated place, so that the machine can absorb and discharge sufficient air.
- (5) Do not install at a place where flammable or explosive goods exist or a place subject to severe dust, salty fog and polluted air.
- (6) This unit shall not be installed indoor and shall be installed in a well-ventilated area.
- (7) Necessary anti-shock measures shall be taken during installation to avoid faults by unusual noise and shock.

### 4.4 Outline dimension of outdoor unit

Unit:mm

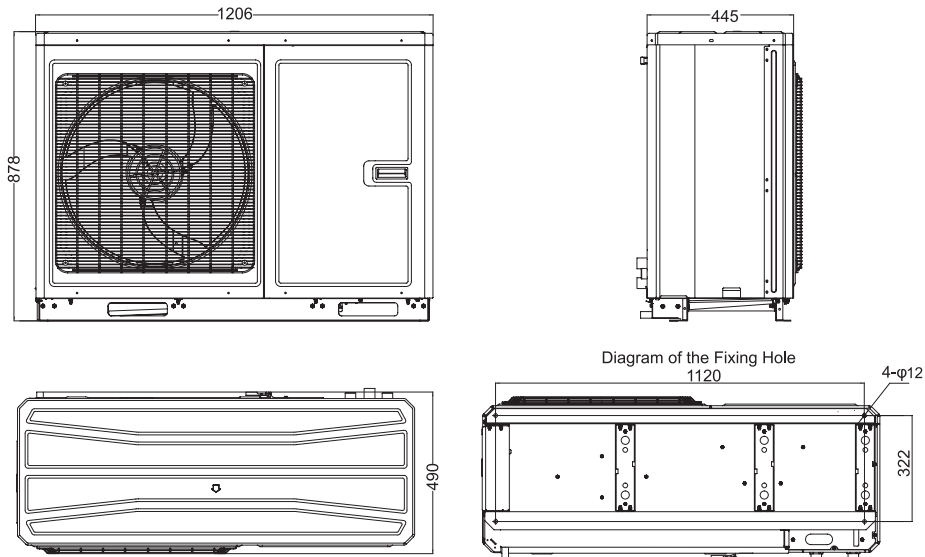

## 4.5 Installation of Monobloc Unit

### 4.5.1 Installation Clearance

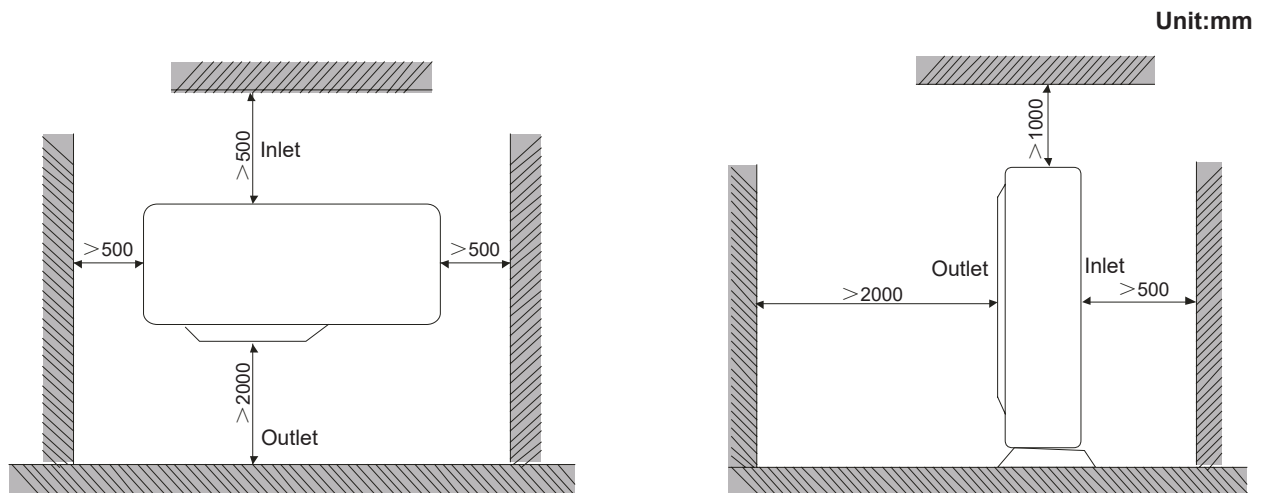

Note: In consideration of space restriction, for the left-handed figure, except the outlet side, distance between the unit and the nearest barrier at other three sides are allowed to be no less than 500mm; for the right-handed figure, distance between the inlet side and the nearest barrier is allowed to be no less than 500mm.

### 4.5.2 Inlets and outlets for wiring and piping



Water return

Water supply

- (1) Take away the original rubber rings;
- (2) Cable field supplied shall go through the cable duct, such as cables for the 2-way valve, 3-way valve, power cable and so on.
- (3) Be careful of separating the power line and the communication line.
- (4) Water inside the main unit is not allowed to be connected to potable water or sanitary water.
- (5) If the water tank is required, the heat exchanger of the water tank should be double-walled and make sure the unit operate normally.

### 4.5.3 Cold Climate Requirements

- (1) For areas with frequent snowfall, please clean up the snow in time to avoid covering unit.
- (2) The unit is installed in areas expecting snow are suggested to be raised with support frames.
- (3) If possible, avoid locations that are likely to accumulate snow. If not possible, a snow guard should be installed on the unit to prevent accumulation of snow on the top of the unit.
- (4) Height of the installation foundation should be higher than the height of the annual average snowfall.
- (5) Snow and other litters shall be removed within at least one meter distance from the unit so as to keep the unit in normal operation.



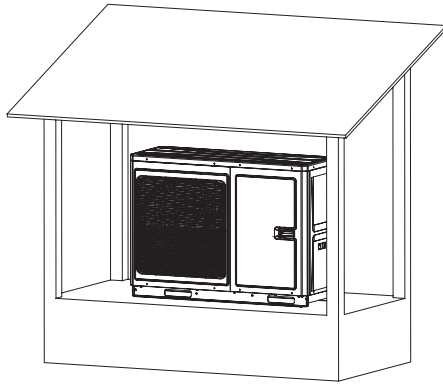

## 4.6 Installation of Hydraulic Unit

### 4.6.1 Available External Static Pressure of Outlet

(1) External lift and flowrate

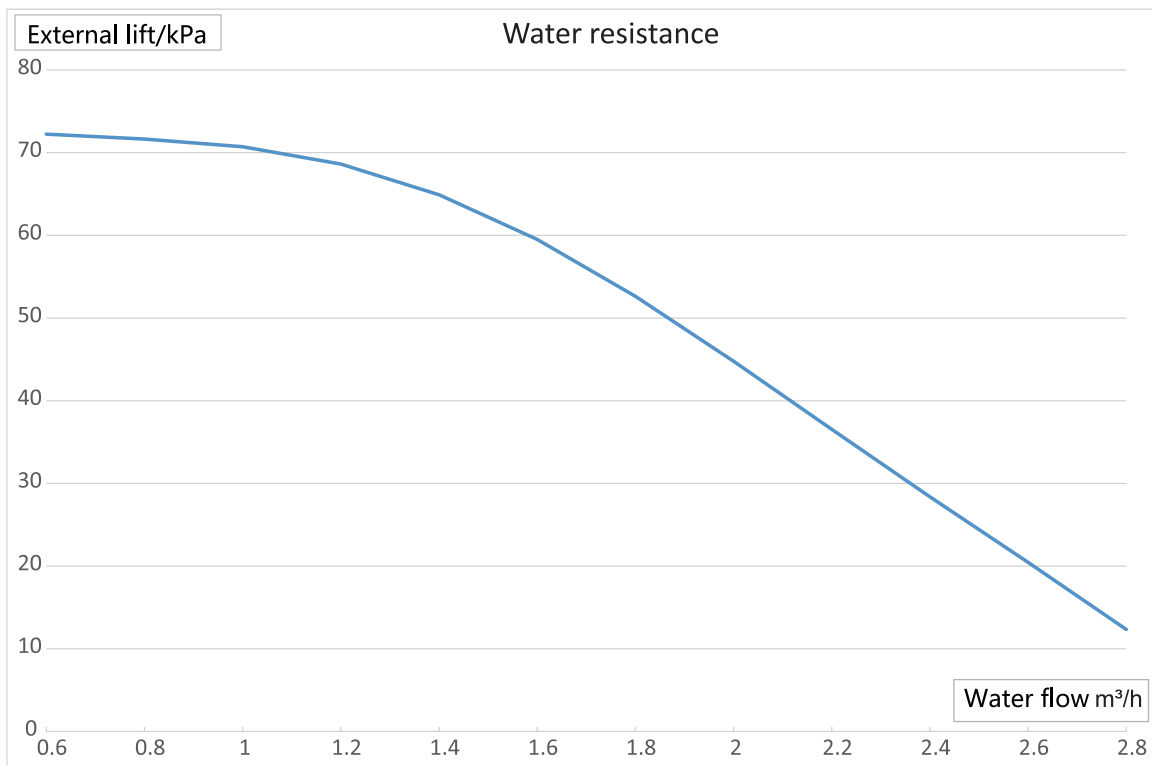

#### Notes

- (a) See the curve above for the maximum external static pressure. The water pump is of variable frequency. And during operation, the water pump will adjust its output based on the actual load.
- (b) Ambient temperature and leaving water temperature upper limit

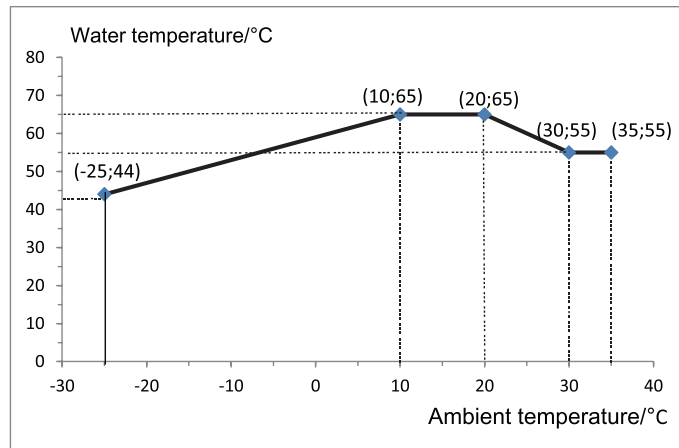

Note: the ambient temperature and water temperature should be subject to the actual operation of the unit.

#### 4.6.2 Water volume and expansion vessel pressure

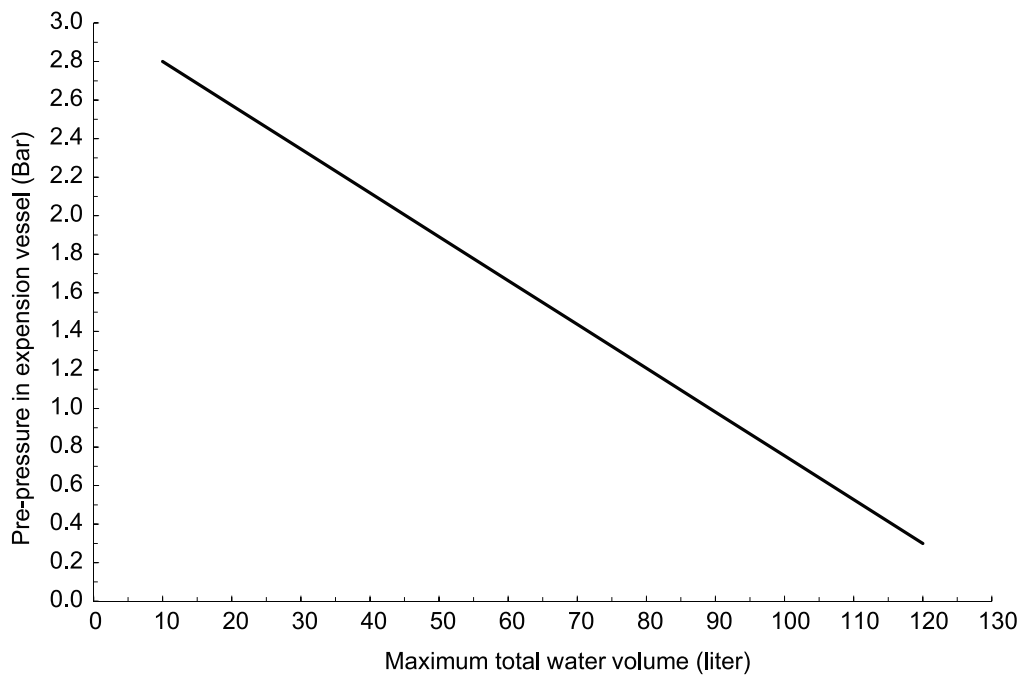

#### Notes

- (a) The expansion vessel is 3 liters and 1.5 bars prepressurized for the unit ;
- (b) Total water volume is 66 liters for the unit; if total water is changed because of installation condition, the pre-pressure should be adjusted to secure proper operation. If the unit is located at the highest position, adjustment is not required;
- (c) Minimum total water volume is 20 liters;
- (d) To adjust pre-pressure, use nitrogen gas by certificated installer.

#### 4.6.3 The method of calculating the charging pressure of expansion vessel

The method of calculating the charging pressure of expansion vessel needed to be adjusted is as follows. During installation, if the volume of water system has changed, please check if the pre-set pressure of the expansion vessel needs to be adjusted according to the following formula:

$$P_g = (H/10 + 0.3) \text{ Bar}$$

(H ---the difference between installing location of indoor unit and the highest spot of water system.)

Ensure that the volume of water system is lower than the maximum volume required in the above figure. If it exceeds the range, the expansion vessel does not meet the installing requirement.

Installation height <sup>1</sup> difference	Water volume	
	<66L	>66L
<12 m	Adjustment is not necessary	1. Pre-set pressure needs to be adjusted according to the above formula. 2. Check if the water volume is lower than the maximum water volume. (with help of the above figure)
> 12 m	1. Pre-set pressure needs to be adjusted according to the above formula. 2. Check if the water volume is lower than the maximum water volume. (with help of the above figure)	The expansion vessel is too small and adjustment is not available.

**Notes**

(a) Installation height difference: the difference between installing location of the unit and the highest spot of water system; if the unit is located at the highest point of the installation, the installation height difference is considered 0m.

(b) Example 1: The 16kW unit is installed 5m below the highest spot of water system and the total volume of the water system is 60L.

(c) Referring to the above figure, it is not necessary to adjust the pressure of the expansion vessel.

(d) Example 2: The unit is installed on the highest spot of the water system and the total water volume is 100L.

(e) As the volume of water system is higher than 66L, it is necessary to adjust the pressure of the expansion vessel be lower.

(f) The formula of calculating pressure

$$P_g = (H/10 + 0.3) = (0/10 + 0.3) = 0.3 \text{ Bar}$$

(g) The maximum volume of the water system is about 118L. As the actual volume of the water system is 100L, the expansion vessel meets the installing requirement.

(h) Adjust the pre-set pressure of the expansion vessel from 1.5Bar to 0.3Bar.

**4.7 Requirements on water quality**

Item	Parametric value	Unit
pH( 25°C)	6.8~8.0	/
Cloudy	< 1	NTU
Chloride	< 50	mg/L
Fluoride	< 1	mg/L
Iron	< 0.3	mg/L
Sulphate	< 50	mg/L
SiO <sub>2</sub>	< 30	mg/L
Hardness(count CaCO <sub>3</sub> )	< 70	mg/L
Nitrate(count N)	< 10	mg/L
Conductance(25°C)	< 300	µs/cm
Ammonia (count N)	< 0.5	mg/L
Alkalinity(count CaCO <sub>3</sub> )	< 50	mg/L
Sulfid	Undetectable	mg/L
Oxygen consumption	< 3	mg/L
Natrium	< 150	mg/L

### 4.8 Wiring of the Terminal Board

Terminal board XT3

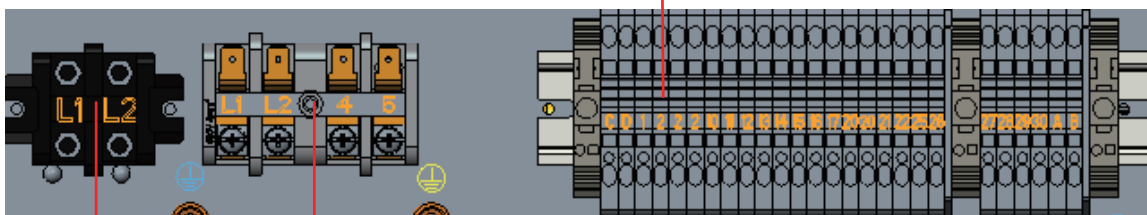
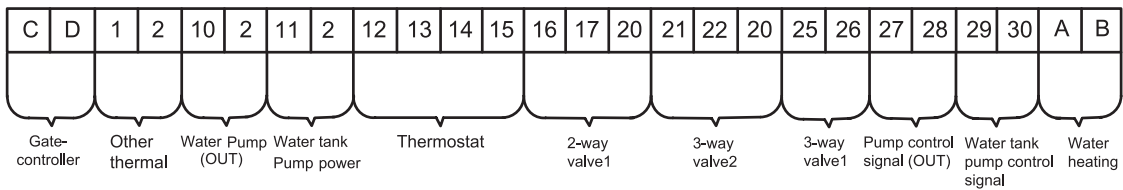

Terminal board XT1

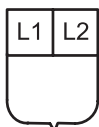

Whole unit power

Terminal board XT4

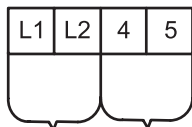

Electric heater power  
Water tank auxiliary electric heater (AC230V 3KW)

### 4.9 Wiring of the 2-Way Valve

The role of 2-way valve 1 is to control the water flow into the underfloor loop. When “Floor Config” is set to “With” for either cooling or heating operation, it will keep open. When “Floor Config” is set to “ Without”, it will keep closed.

General Information

Type	Power	Operating Mode	Supported
NO 2-wire	208/230VAC, 1Ph, 60HZ	Closing water flow	Yes
		Opening water flow	Yes
NC 2-wire	208/230VAC, 1Ph, 60HZ	Closing water flow	Yes
		Opening water flow	Yes

- (1) Normal Open type. When electric power is NOT supplied, the valve is open. (When electric power is supplied, the valve is closed.)
- (2) Normal Closed type. When electric power is NOT supplied, the valve is closed. (When electric power is supplied, the valve is open.)
- (3) How to Wire 2-Way Valve:

Follow steps below to wire the 2-way valve.

Step 1. Uncover the front cover of the unit and open the control box.

Step 2. Find the terminal block and connect wires as below.

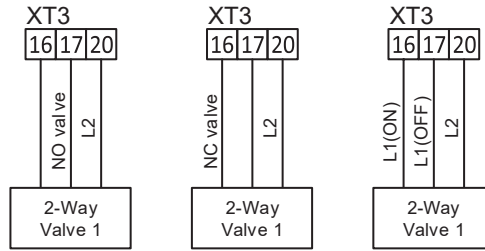

**! WARNING**

- Normal Open type should be connected to wire (OFF) and wire (N) for valve closing in cooling mode.
  - Normal Closed type should be connected to wire (ON) and wire (N) for valve closing in cooling mode.
- (ON) : Line signal (for Normal Open type) from PCB to 2-way valve  
 (OFF) : Line signal (for Normal Closed type) from PCB to 2-way valve

**4.10 Wiring of Other Thermal**

Other thermal is allowed for the equipment and controlled in such a way that the mainboard will output 230V when outdoor temperature is lower than the set point for startup of the aother thermaluxiliary heat source.

Note: Other thermal and Optional Electric Heater CANNOT be installed at the same time.

Step 1. Other thermal installation

Other thermal should be installed with monobloc unit parallel. Moreover, an accessory called optional water temperature sensor(5 meter length) shall be installed at the same time.

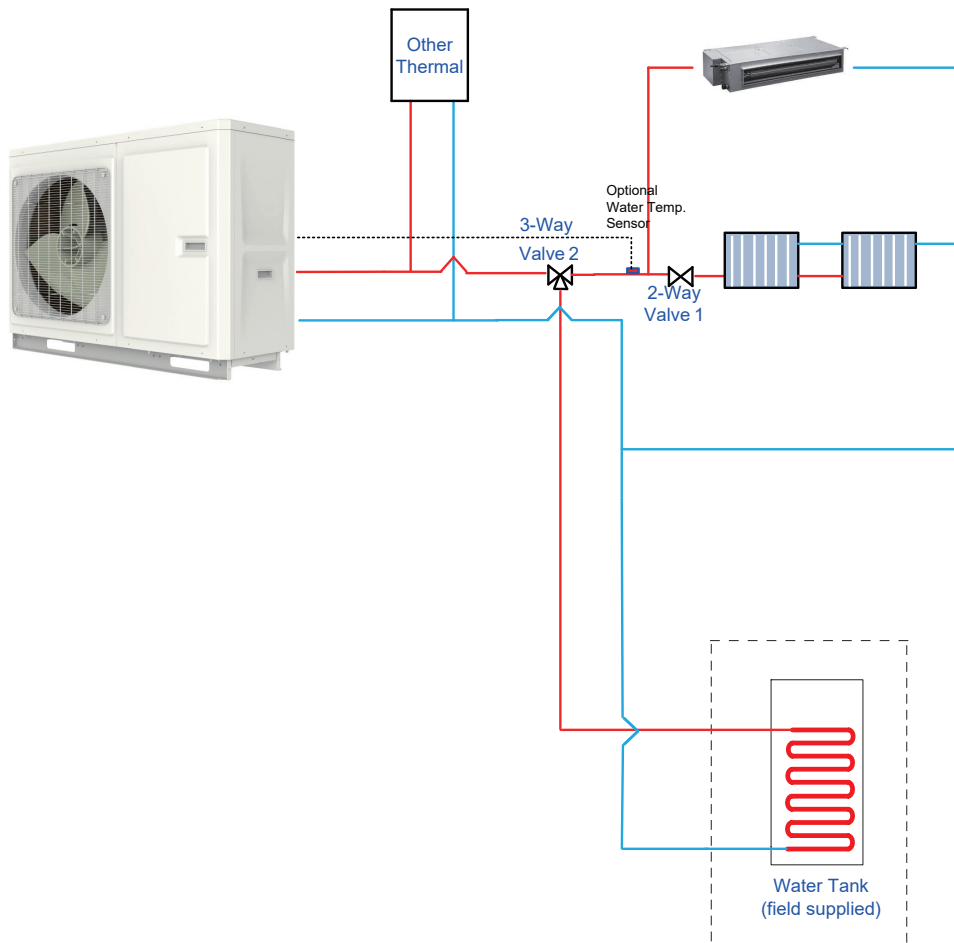

Step 2. Electric wiring work

Other thermal L and N connect to XT3~1,2.

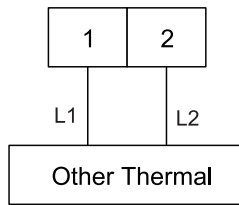

Optional water temperature sensor connect to AP1 CN16.

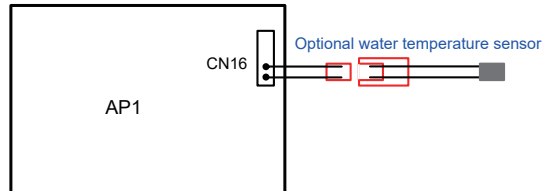

Step 3. Wired controller setting

Other thermal should be selected "with" if necessarily from COMMISSION → FUNCTION, then set switch on (outdoor) temperature and control logic(1/2/3).

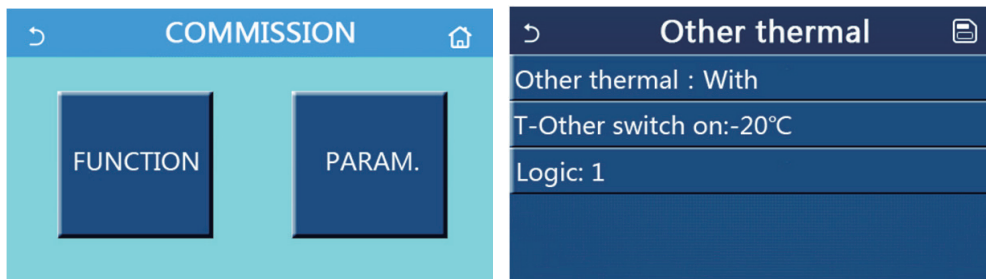

**4.11 Wiring of Optional Electric Heater**

Optional electric heater is allowed for the equipment and controlled in such a way when outdoor temperature is lower than the set point for startup of the optional electric heater.

Step 1. Optional electric heater installation

Optional electric heater should be installed with monobloc unit in series. Moreover, an accessory called optional water temperature sensor (5 meter length) shall be installed at the same time. The optional electric heater could be 1 group or 2 group, and only works for space heating.

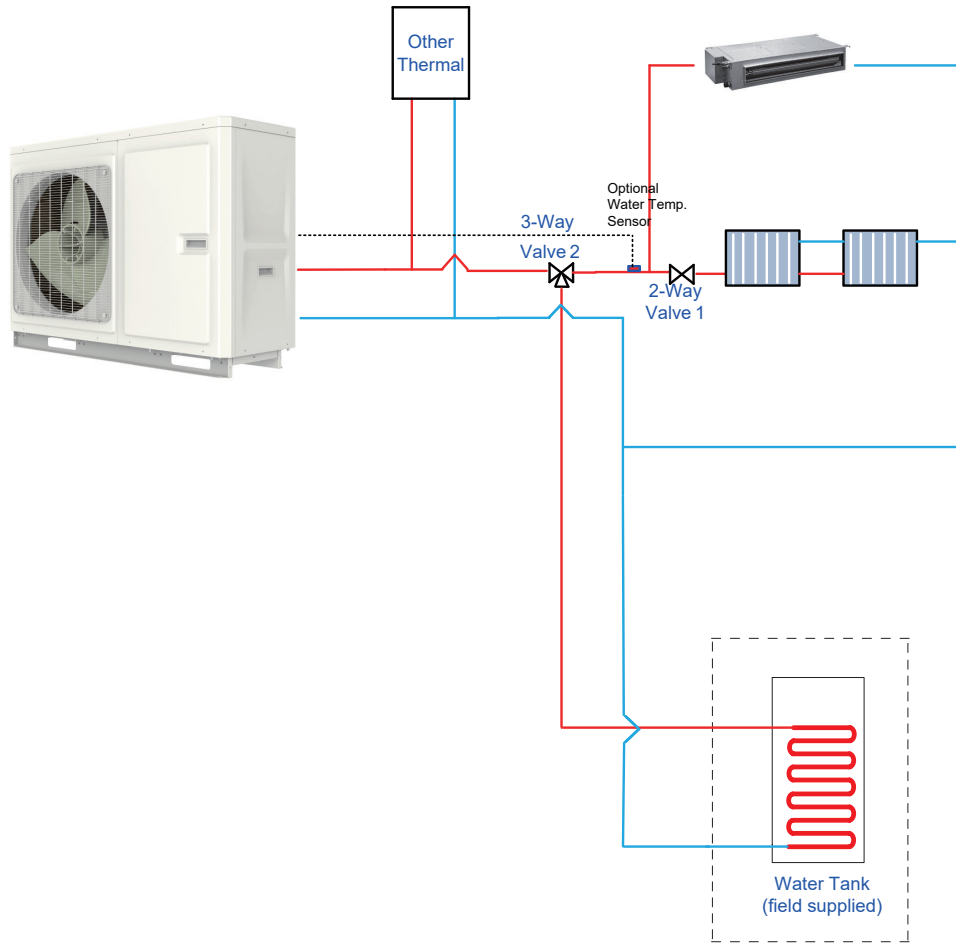

Step 2. Wired controller setting

Optional electric heater should be selected "1/2" group if necessary from COMMISSION → FUNCTION, then set switch on (outdoor)temperature and control logic(1/2).

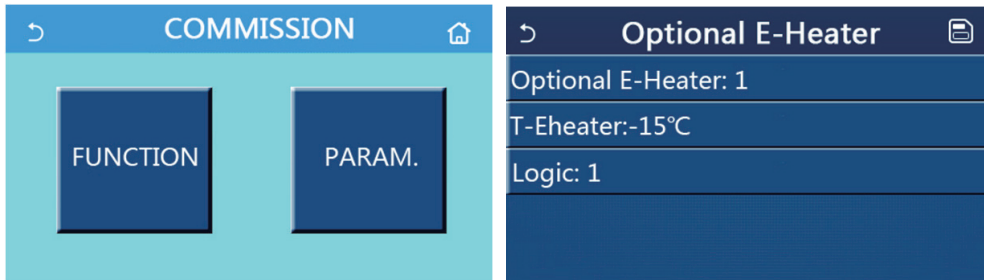

4.12 Wiring of the Gate-Controller

If there is gate control function, installation guide follow as:



### 4.13 Wiring of the Remote Air Temperature Sensor

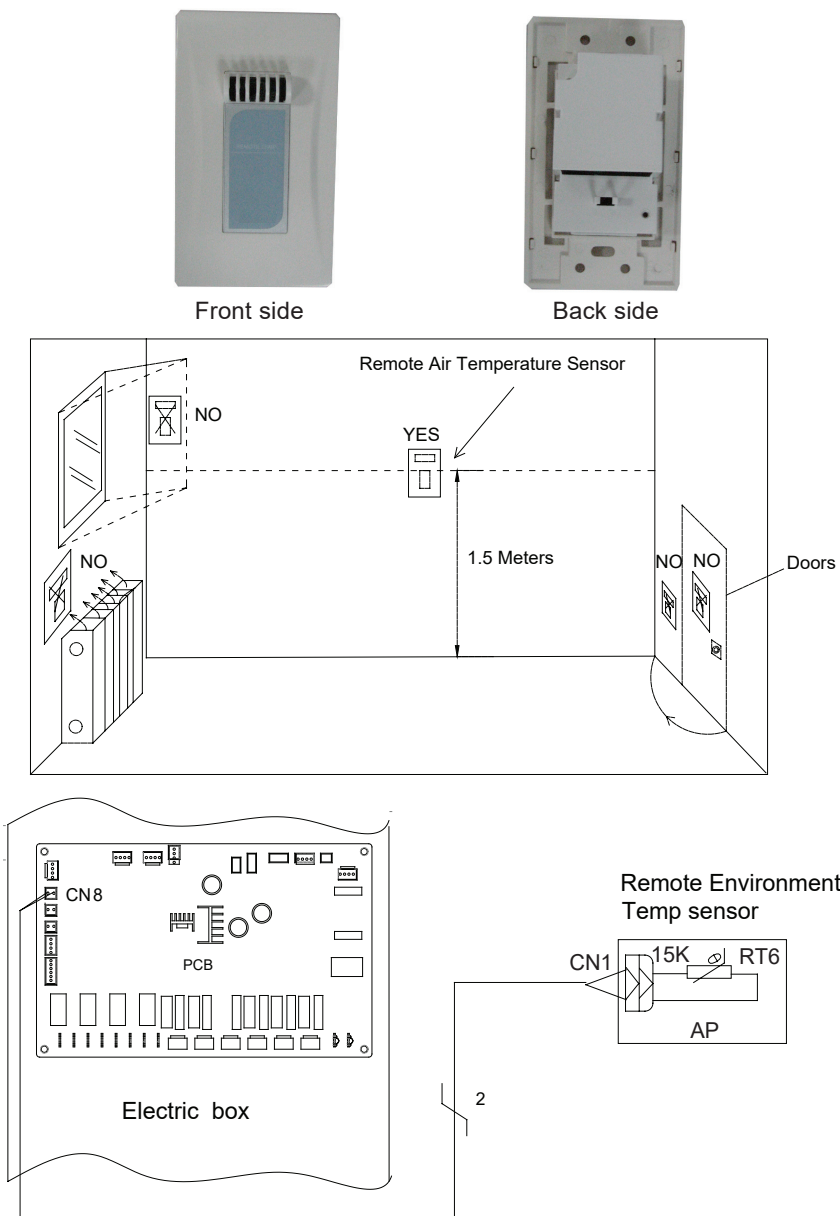

**Notes:**

- (a) Distance between the indoor unit and the remote air temperature sensor should be less than 15m due to length of the connection cable of remote air temperature sensor;
- (b) Height from floor is approximately 1.5m;
- (c) Remote air temperature sensor cannot be located where the area may be hidden when door is open;
- (d) Remote air temperature sensor cannot be located where external thermal influence may be applied;
- (e) Remote air temperature sensor should be installed where space heating is mainly applied;
- (f) After the remote air temperature sensor is installed, it should be set to “With” through the wired controller so as to set the remote air temperature to the control point.



#### 4.14 Wiring of the Thermostat

Installation of the thermostat is very similar to that of the remote air temperature sensor.

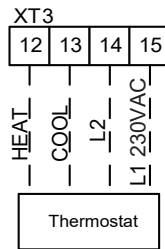

##### How to Wire Thermostat

- (1) Uncover the front cover of indoor unit and open the control box ;
- (2) Identify the power specification of the thermostat, if it is 230V, find terminal block XT3 as NO.12~15;
- (3) If it is the heating/cooling thermostat, please connect wire as per the figure above.

#### ⚠ CAUTION

- (a) 230V power supply can be provided to the thermostat by the Versati III heat pump.
- (b) Setting temperature by the thermostat(heating or cooling) should be within the temperature range of the product ;
- (c) For other constrains, please refer to previous pages about the remote air temperature sensor;
- (d) Do not connect external electric loads. Wire 230V AC should be used only for the electric thermostat;
- (e) Never connect external electric loads such as valves, fan coil units, etc. If connected, the mainboard of the unit can be seriously damaged;
- (f) Installation of the thermostat is very similar to that of the remote air temperature sensor.

## 5 Commissioning and Test Run



### 5.1 Check before startup

For safety of users and the unit, the unit must be commissioned for startup. The procedures are as below:

The following items shall be performed by qualified maintenance personnel.		
Confirm with the sales engineer, dealer, installing contractor and users to make sure the following items finished (√) or to be finished (×).		
No.	Confirmation of Installation	√
1	Ensure the veracity of the contents . If not, commissioning will be refused.	<input type="checkbox"/>
2	Is there written notice in which service items are shown in respect of unqualified installation?	<input type="checkbox"/>
3	Are Application for Installation and Debugging list filled together?	<input type="checkbox"/>
No.	Pre-check	√
1	Is appearance of the unit and internal pipeline system in good condition during conveying, carrying or installation?	<input type="checkbox"/>
2	Check the accessories attached with the unit for quantity, package and so on.	<input type="checkbox"/>
3	Make sure there is drawings in terms of electricity, control, design of pipeline and so on.	<input type="checkbox"/>
4	Check if installation of the unit is stable enough and there is enough space for operation and service.	<input type="checkbox"/>
5	Completely test refrigerant pressure of each unit and perform leakage detection of the unit.	<input type="checkbox"/>
6	Is the water tank installed stably and supported securely when the water tank is full?	<input type="checkbox"/>
7	Are there proper heat insulating measures for the water tank, outlet/inlet pipes and water replenishing pipe proper?	<input type="checkbox"/>
8	Are the nilometer of water tank, water temperature indicator, controller, manometer, pressure relief valve and automatic discharge valve etc. installed and operated properly?	<input type="checkbox"/>
9	Does power supply accord with the nameplate? Do power cords conform to applicable requirements?	<input type="checkbox"/>
10	Is power supply and control wiring connected properly according to wiring diagram? Is earthing safe? Is each terminal stable?	<input type="checkbox"/>
11	Are connection pipe, water pump, manometer, thermometer, valve etc. are installed properly?	<input type="checkbox"/>
12	Is each valve in the system open or closed according to requirements?	<input type="checkbox"/>
13	Confirm that the users and inspection personnel of Part A are at site.	<input type="checkbox"/>
14	Is Installation Check-up Table completed and signed by the installation contractor?	<input type="checkbox"/>
Attention: If there is any item marked with ×, please notify the contractor. Items listed above are just for reference.		
Confirmed Items after pre-checking	<b>General Evaluation: Commissioning</b> <input type="checkbox"/> <b>Service</b> <input type="checkbox"/>	
	Judge the following items (When no problem has been pointed out, it indicates the unit is in good condition.)	
	a: Power supply and electric control system      b: Loading calculation	
	c: Heating problems of Unit      d: Noise problem	
	e: Pipeline problem      f: Others	
	Normal commissioning work can't be performed unless all installation items are qualified. If there is any problem, it must be solved firstly. The installer will be responsible for all costs for delay of commissioning and re-commissioning incurred by any problem which is not solved immediately.	
	Submit schedule of service reports to installer.	
	Is the written service report which should be signed after communication provided to installer?	
	Yes ( )      No ( )	

### 5.2 Trial run

Trial run is testing whether the unit can run normally. If the unit cannot run normally, find and solve problems until the trial run is satisfactory. All inspections must meet the requirements before performing the trial run. Trial run should follow the content and steps of the table below:

The following procedure should be executed by qualified maintenance personnel.	
No.	Start up the pretest procedure
Notice: before test, ensure that all power must be cut off, including the far- end power switch, otherwise, it may cause casualty.	
1	Ensure that the compressor of the unit is preheated for 8h.
 Caution: heat the lubricating oil at least 8h in advance to prevent refrigerant from mixing with the lubricating oil, which may cause damage to the compressor when starting up the unit.	
2	Check whether the phase sequence of the main power supply is correct. If not, correct the phase sequence firstly.
 Recheck the phase sequence before start-up to avoid reverse rotation of the compressor which may damage the unit.	
3	Apply the multimeter to measure the insulation resistance between each outdoor phase and earth as well as between phases.
 Caution: defective earthing may cause electric shock.	
No.	Ready to start
1	Cut off all temporary power supply, resume all the insurance and check the electricity for the last time.
	Check the power supply and voltage of the control circuit; _____V must be $\pm 10\%$ within the range of rated operating power.
No.	Start up the unit
1	Check all the conditions needed to start up the unit: oil temperature, mode, required load etc.
2	Start up the unit, and observe the operation of compressor, electronic expansion valve, fan motor and water pump etc.
	Note: the unit will be damaged under abnormal running state. Do not operate the unit in states of high pressure and high current.
Others:	
Items for acceptance after commissioning	Estimation or suggestion on the general running situation: good, correction required
	Identify the potential problem (When no problem has been pointed out, it indicates the unit is in good condition.)
	a. problem of power supply and electric control system:
	b. problem of load calculation:
	c. outdoor refrigerant system:
	d. noise problem:
	e. problem of indoor and piping system:
	h. other problems:
During operation, it is needed to charge for the maintenance due to non-quality problems such as incorrect installation and maintenance.	
<b>Acceptance</b>	
Is the user trained as required? Please sign. Yes( ) No( )	

## TEST OPERATION & TROUBLESHOOTING & MAINTENANCE

### 1 Precheck

#### 1.1 Check for Wiring

 **NOTE**

- Do not check for the power supply unless proper checkout equipment has prepared and preventive measures have been taken, otherwise it would lead to severe injury.

- (1) Are sizes of connection lines and the air switch properly selected?
- (2) Does wiring comply with relative standards and electric codes?
- (3) Is there any incorrect wiring?
- (4) Does each contact work properly?
- (5) Is the power supply and insulation proper?
- (6) Are initial set points of control and protective elements satisfied?

#### 1.2 Check for the Water System

- (1) Are water inlet and outlet directions correct?
- (2) Is the water piping cleaned? Are there foreign matters at the pipe joints? Is the water quality satisfied?
- (3) Is insulation of water pipes in good condition?
- (4) Does exhaust valve of the water system work properly?

#### 1.3 Check for the Communication System

When the unit is powered on, check for the communication system, including: communication between AP1 and AP2, between the wired controller and the main board. When there is unusual communication, this error will be displayed at the wired controller. Then, check out the cause according to the displayed error. See the figure below for wiring of the communication system.

#### 1.4 Trial Run

Start the unit when there is no any problem for wiring and piping. After startup, check for the electrostatic expansion valve, water pump, fan, and compressor to see if they work normally. When there is any error, solve it according to the troubleshooting flowchart covered in this manual. However, if the troubleshooting flowchart is still unhelpful, please contact GREE sales distributor.

## 2 Error Code List

- (1) Complete unit code

Code Indication	Error Name	Source of Error Signal	Control Description
F4	Ambient temperature sensor error	<ol style="list-style-type: none"> <li>① The plug on temperature sensor is not correctly connected to the socket on mainboard.</li> <li>② The resistance of temperature sensor is not correct.</li> </ol>	It will be automatically cleared after the failure is removed.
d6	Defrosting temperature sensor error	<ol style="list-style-type: none"> <li>① The plug on temperature sensor is not correctly connected to the socket on mainboard.</li> <li>② The resistance of temperature sensor is not correct.</li> </ol>	It will be automatically cleared after the failure is removed.

Code Indication	Error Name	Source of Error Signal	Control Description
F7	Discharge temperature sensor error	<ul style="list-style-type: none"> <li>① The plug on temperature sensor is not correctly connected to the socket on mainboard.</li> <li>② The resistance of temperature sensor is not correct.</li> </ul>	It will be automatically cleared after the failure is removed.
F5	Suction temperature sensor error	<ul style="list-style-type: none"> <li>① The plug on temperature sensor is not correctly connected to the socket on mainboard.</li> <li>② The resistance of temperature sensor is not correct.</li> </ul>	It will be automatically cleared after the failure is removed.
F2	Economizer inlet temperature sensor	<ul style="list-style-type: none"> <li>① The plug on temperature sensor is not correctly connected to the socket on mainboard.</li> <li>② The resistance of temperature sensor is not correct.</li> </ul>	It will be automatically cleared after the failure is removed.
F6	Economizer outlet temperature sensor	<ul style="list-style-type: none"> <li>① The plug on temperature sensor is not correctly connected to the socket on mainboard.</li> <li>② The resistance of temperature sensor is not correct.</li> </ul>	It will be automatically cleared after the failure is removed.
EF	Fan error	<ul style="list-style-type: none"> <li>① The main control board 2 is damaged.</li> <li>② The wire connecting the wiring terminals of the mainboard breaks.</li> </ul>	If it occurs for 6 times during one hour, it should be cleared by deenergization. If it occurs for less than 6 times, it will be automatically cleared.
E1	High pressure protection	<ul style="list-style-type: none"> <li>① Comp High-pressure switch is broken or the wiring is loose.</li> <li>② The water in the tank is not enough.</li> <li>③ The installation of tank temp sensor is not correct.</li> <li>④ The gas valve and liquid valve are not fully open.</li> <li>⑤ The electronic expansion valve cannot work normally.</li> </ul>	De-energize the unit and then, energize it again. If the malfunction is removed, the code will be cleared.
E3	Low pressure protection	<ul style="list-style-type: none"> <li>① Comp Low-pressure switch is broken or the wiring is loose.</li> <li>② The system has leaked.</li> <li>③ The fans stop running or reverse.</li> </ul>	It will be cleared if the malfunction is removed after the unit has been turned off.
E4	High discharge protection	<ul style="list-style-type: none"> <li>① The resistance of temperature sensor is not correct.</li> <li>② The electronic expansion valve is blocked.</li> <li>③ The system has leaked.</li> <li>④ The main control board 2 is damaged.</li> </ul>	It will be cleared if the discharge temp is lower than 92°C .

Code Indication	Error Name	Source of Error Signal	Control Description
E6	Communication error between the main boards	<ul style="list-style-type: none"> <li>① The communication line of the unit is not connected.</li> <li>② The communication line is not through.</li> <li>③ The communication line of the unit is not connected correctly.</li> <li>④ The two ends of communication line are not mounted with magnetic ring.</li> <li>⑤ The unit is not electrically powered.</li> </ul>	It will be cleared once communication recovers or it will be shown all the time.
E6	Communication error between the main control board 2 and the drive board	<ul style="list-style-type: none"> <li>① The communication line of the unit is not connected.</li> <li>② The communication line is not through.</li> <li>③ The communication line of the unit is not connected correctly.</li> <li>④ The two ends of communication line are not mounted with magnetic ring.</li> <li>⑤ The unit is not electrically powered.</li> </ul>	It will be cleared once communication recovers or it will be shown all the time.
E6	Communication error between the control panel and indoor main board	<ul style="list-style-type: none"> <li>① The communication line of the unit is not connected.</li> <li>② The communication line is not through.</li> <li>③ The communication line of the unit is not connected correctly.</li> <li>④ The two ends of communication line are not mounted with magnetic ring.</li> <li>⑤ The unit is not electrically powered.</li> </ul>	It will be cleared once communication recovers or it will be shown all the time.
Fc	High pressure sensor error	<ul style="list-style-type: none"> <li>① The sensor is damaged.</li> <li>② The wire of the sensor is loose.</li> <li>③ The position of the sensor is wrong.</li> </ul>	It will be automatically cleared after the failure is removed.
F9	Leaving water temperature sensor error for the plate type heat exchanger of the heat pump	<ul style="list-style-type: none"> <li>① The plug on temperature sensor is not correctly connected to the socket on mainboard.</li> <li>② The resistance of temperature sensor is not correct.</li> </ul>	It will be automatically cleared after the failure is removed.
dH	Leaving water temperature sensor error for the auxiliary electric heat of the heat pump	<ul style="list-style-type: none"> <li>① The plug on temperature sensor is not correctly connected to the socket on mainboard.</li> <li>② The resistance of temperature sensor is not correct.</li> </ul>	It will be automatically cleared after the failure is removed.
/	Entering water temperature sensor error of the plate type heat exchanger of the heat pump	<ul style="list-style-type: none"> <li>① The plug on temperature sensor is not correctly connected to the socket on mainboard.</li> <li>② The resistance of temperature sensor is not correct.</li> </ul>	It will be automatically cleared after the failure is removed.

Code Indication	Error Name	Source of Error Signal	Control Description
FE	Water tank temperature sensor error	① The plug on temperature sensor is not correctly connected to the socket on mainboard. ② The resistance of temperature sensor is not correct.	It will be automatically cleared after the failure is removed.
F0	Remote room temperature sensor error	① The plug on temperature sensor is not correctly connected to the socket on mainboard. ② The resistance of temperature sensor is not correct.	It will be automatically cleared after the failure is removed.
Ec	Protection for the flow switch of the heat pump	① The switch is damaged. ② The wire of the switch is loose. ③ The position of the switch is wrong	It will be cleared after the unit is turned off.
E2	Indoor anti-frozen protection	① The resistance of temperature sensor is not correct. ② The electronic expansion valve cannot work normally.	It will be cleared once malfunction is removed or it will be shown all the time; but it will be cleared immediately when switching operation mode.
Ed	outlet temperature High-temp protection	① The resistance of temperature sensor is not correct. ② The plug on temperature sensor is not correctly connected to the socket on mainboard. ③ The main control board is damaged.	De-energize the unit and then, energize it again. If the malfunction is removed, the code will be cleared.
EH	Welding protection to the auxiliary electric heater 1 of the heat pump	The AC contactor is damaged.	De-energize the unit and then, energize it again. If the malfunction is removed, the code will be cleared.
EH	Welding protection to the auxiliary electric heater 2 of the heat pump	The AC contactor is damaged.	De-energize the unit and then, energize it again. If the malfunction is removed, the code will be cleared.
EH	Welding protection to the water tank electric heater	The AC contactor is damaged.	De-energize the unit and then, energize it again. If the malfunction is removed, the code will be cleared.

Code Indication	Error Name	Source of Error Signal	Control Description
c5	Jumper cap error	Incorrect jumper is used or the jumper is not fixed securely.	De-energize, re-energize and re-inspect it. This error cannot be cleared automatically.
E6	Communication error between the control panel and the unit	<ul style="list-style-type: none"> <li>① The communication line of the unit is not connected.</li> <li>② The communication line is not through.</li> <li>③ The communication line of the unit is not connected correctly.</li> <li>④ The two ends of communication line are not mounted with magnetic ring.</li> <li>⑤ The unit is not electrically powered.</li> </ul>	It will be cleared once communication recovers or it will be shown all the time.
F3	Refrigerant vapor line temperature sensor error	<ul style="list-style-type: none"> <li>① The plug on temperature sensor is not correctly connected to the socket on mainboard.</li> <li>② The resistance of temperature sensor is not correct.</li> </ul>	It will be automatically cleared after the failure is removed.
F1	Refrigerant liquid line temperature sensor error	<ul style="list-style-type: none"> <li>① The plug on temperature sensor is not correctly connected to the socket on mainboard.</li> <li>② The resistance of temperature sensor is not correct.</li> </ul>	It will be automatically cleared after the failure is removed.
U7	4-way valve error	The jammed 4-way valve fails to reverse the operating mode.	De-energize and then re-energize it, or clear this error manually. It cannot be cleared automatically.



## (2) Drive failure code

Item		Display on Nixie Tube of the Unit	Display on Control Panel	Others
Inverter Drive Failure	Reset of Drive System	P0	Driver reset	
	Startup Failure of Compressor	Lc	Start failure	
	Current protection of compressor	P5	Com. over-cur.	
	Communication failure	P6	Drive-main com.	
	Sensor failure of heat sink	P7	T-mod. sensor	
	Overheat protection of heat sink	P8	Overtemp.-mod.	
	AC current protection (input side)	PA	AC curr. pro.	
	Current sensor failure	Pc	Current sen.	
	Overvoltage protection	PH	DC over-vol.	
	Under-voltage protection	PL	DC under-vol.	
	Charge circuit failure	PU	Charge circuit	
	IPM protection	H5	IPM defective	
	Desynchronizing of motor	H7	Desynchronize	
	PFC abnormality	Hc	PFC defective	

### 3 Flow Chart of Troubleshooting

(1) Comp high-pressure protection E1

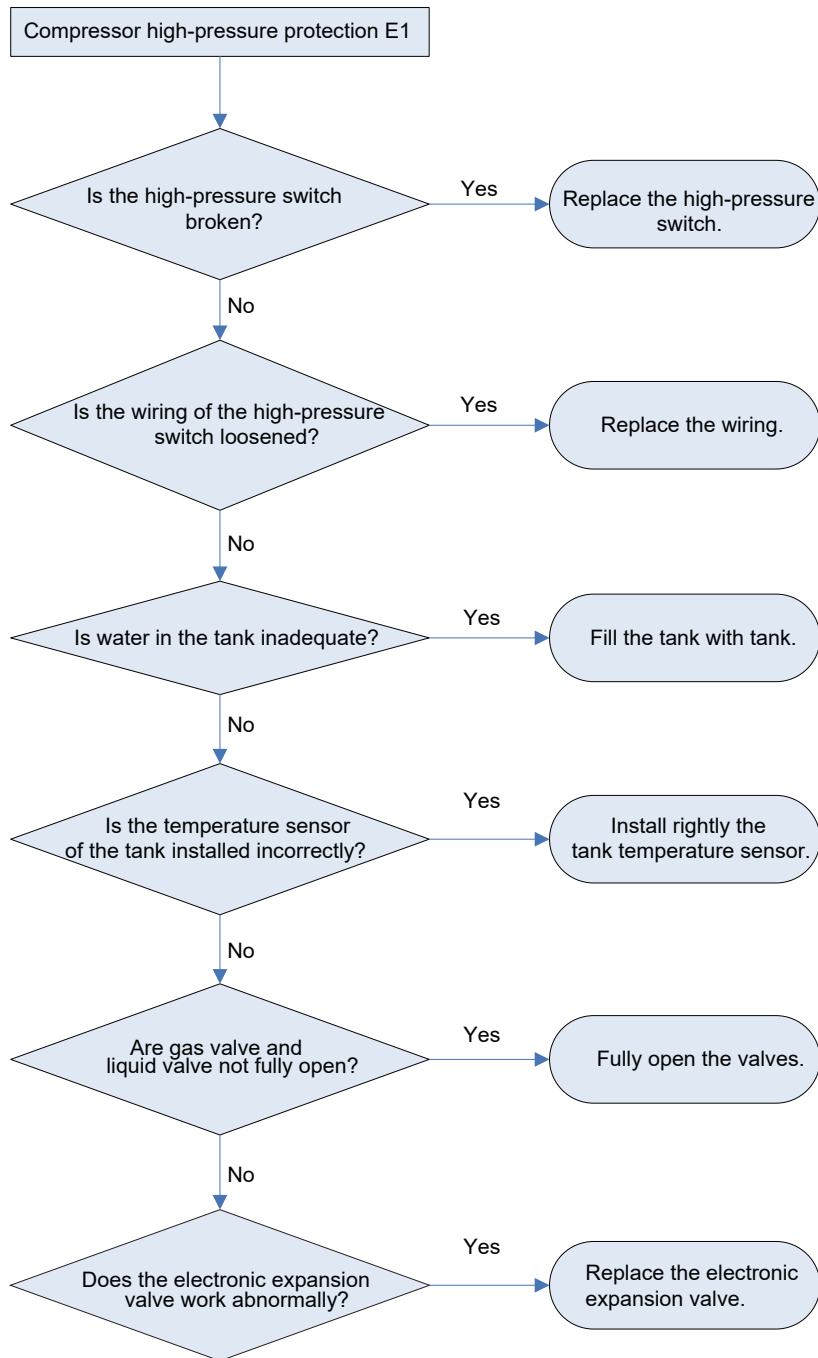

(2) Comp Low- pressure protection E3

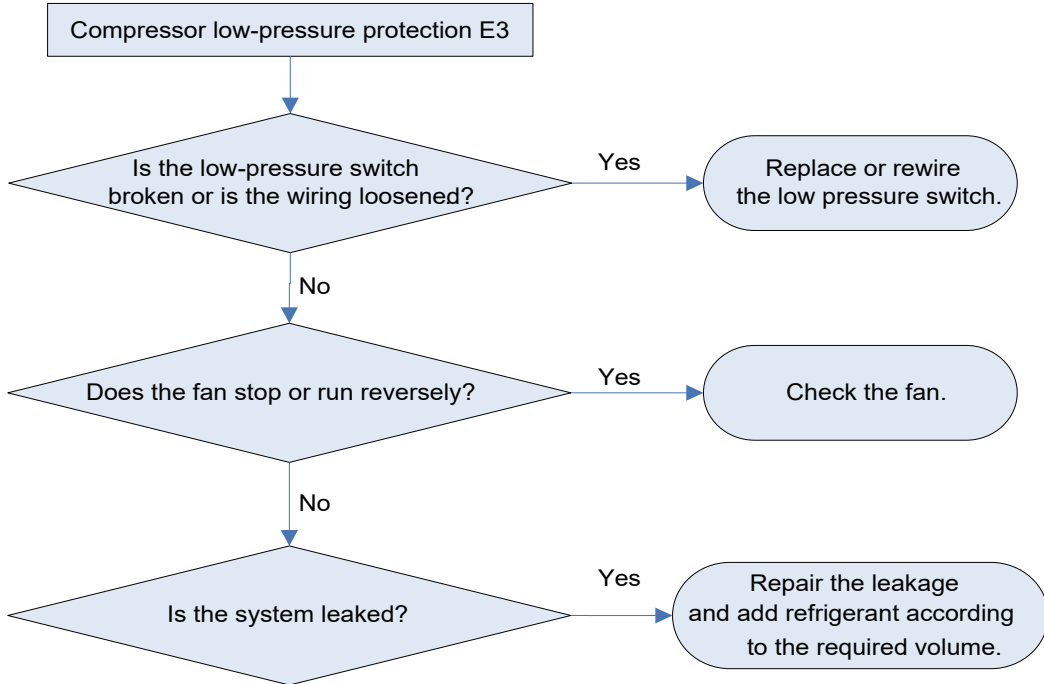

(3) Comp discharge temp protection E4

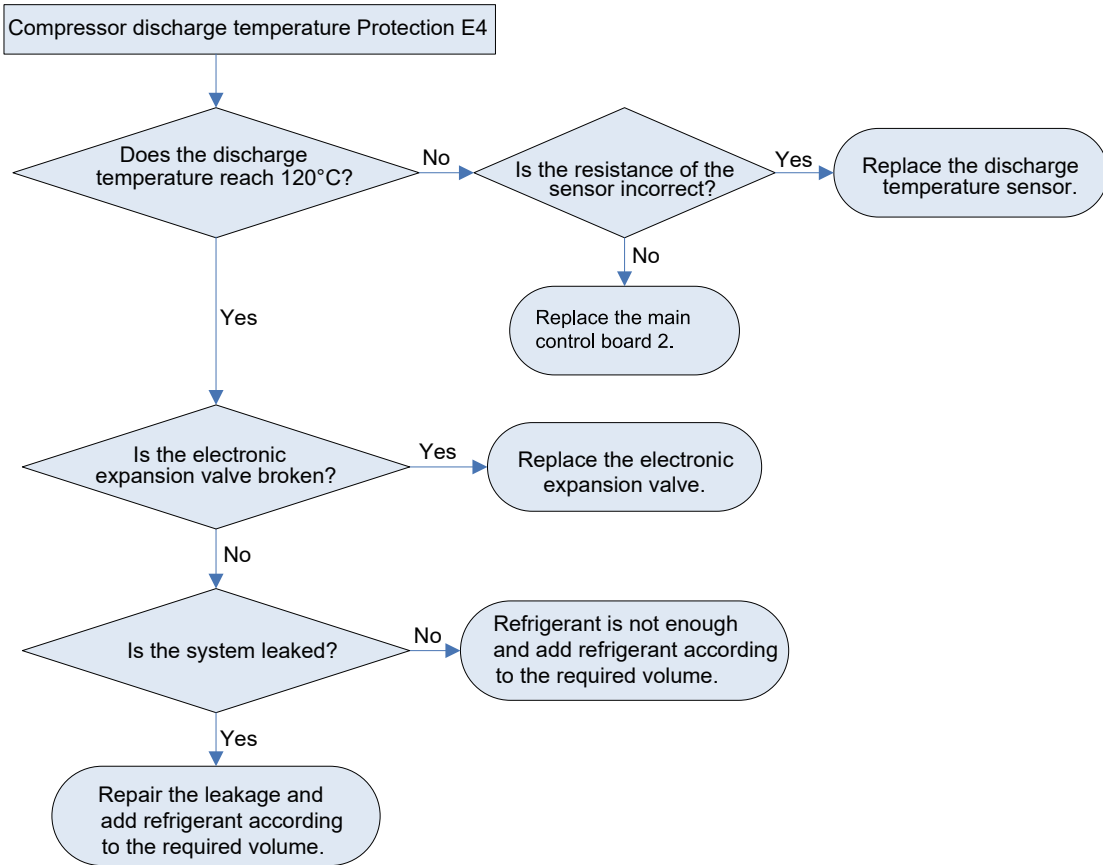

(4) Outdoor fan error EH

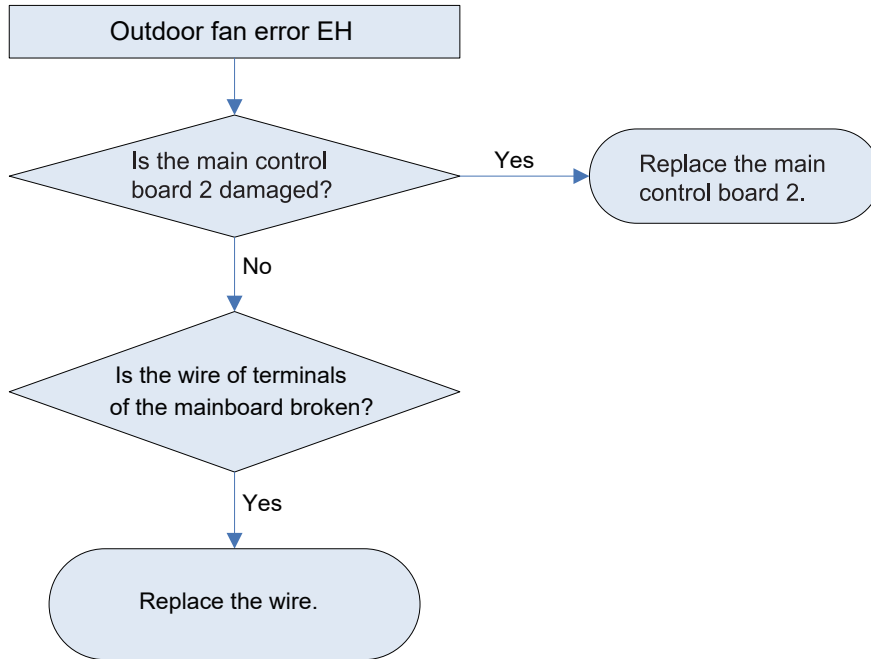

(5) Temperature sensor error

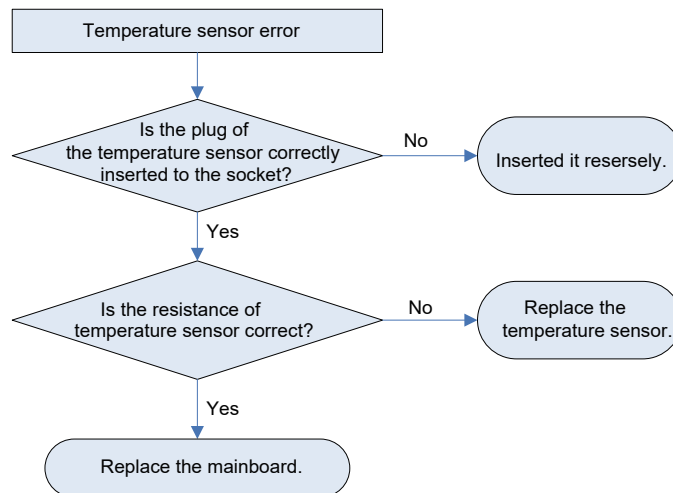

## (6) Communication malfunction E6

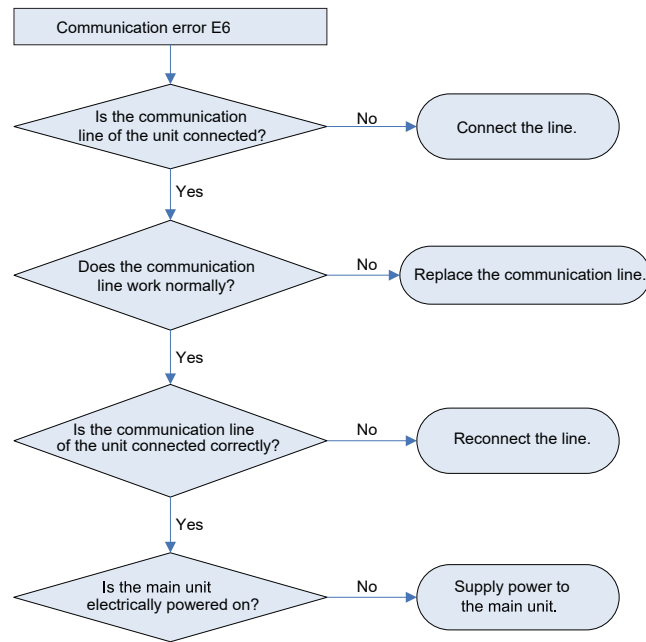

## 4 Troubleshooting for the Drive Board

### 4.1 Diagnosis of the driving board

- (1) Overvoltage of direct current: It is detected that the voltage of direct current is over 410V after energization. If the protection occurs for 6 times within one hour, it can not be resumed unless it is deenergized and reenergized.
- (2) Under-voltage of direct current: It is detected that the voltage of direct current is lower than 200V after startup of the unit. If the protection occurs for 6 times within one hour, it can not be resumed unless it is deenergized and reenergized.
- (3) PFC abnormality: The protection against PFC abnormality is detected after the PFC works for 10s. If the protection occurs for 6 times within one hour, it can not be resumed unless it is deenergized and reenergized.
- (4) IPM protection of driving board: The protection against IPM abnormality is detected after the IPM works for 10s. If the protection occurs for 6 times within one hour, it can not be resumed unless it is deenergized and reenergized.
- (5) Overcurrent protection of compressor: The protection occurs when the instantaneous current is detected over 35A. If the protection occurs for 6 times within one hour, it can not be resumed unless it is deenergized and reenergized.
- (6) Superheat protection of IPM driving board: The protection occurs when the internal temperature of IPM is detected higher than 100°C. If the protection occurs for 6 times within one hour, it can not be resumed unless it is deenergized and reenergized.
- (7) Abnormal sensor of radiating fin: The protection occurs when break circuit or short circuit of the temperature sensor on top of the IPM module. If the protection occurs for 6 times within one hour, it can not be resumed unless it is deenergized and reenergized.
- (8) Communication error of conversion driver and main controller: the driving board can not communicate with the main controller normally. This error can be resumed automatically.

## 4.2 Diagnosis flowchart of the driving board

### (1) PFC abnormality

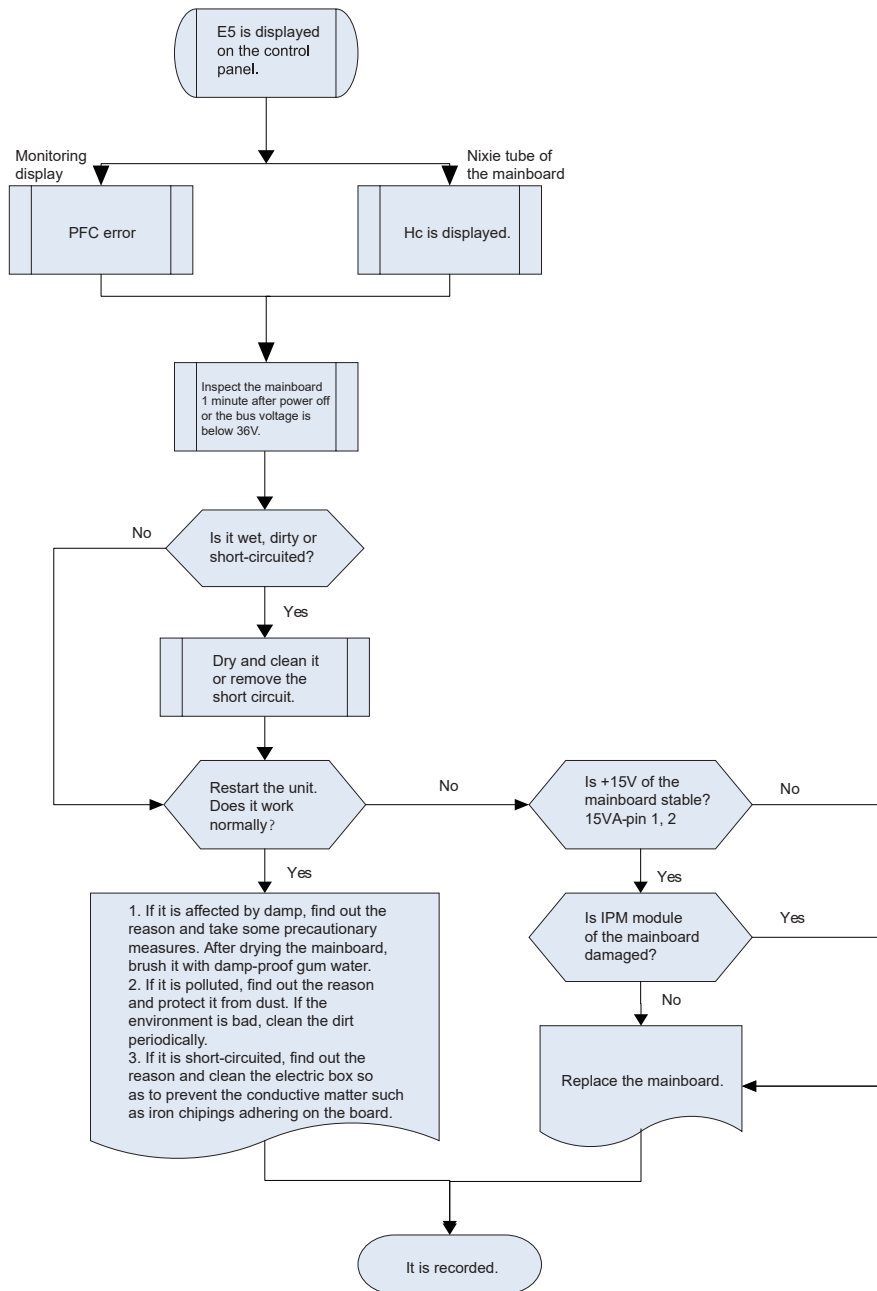

(2) IPM protection

The reasons may be:

- Untight screws of IPM module
- damaged IPM module
- defective radiating of IPM module
- abnormal +15V power strip
- abnormal PFC module
- wire connection error with PFC
- wrong cement resistance RS1-RS3 of driving board
- abnormal compressor
- interference

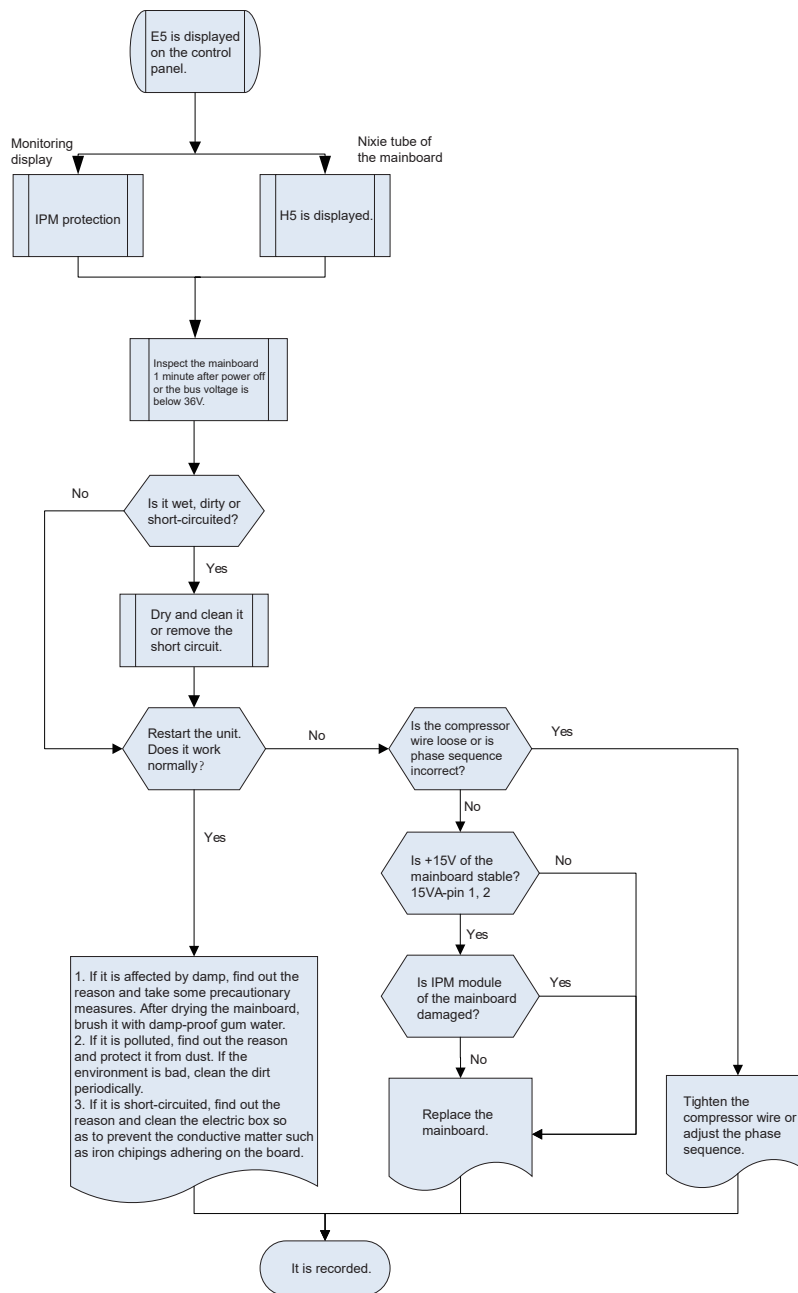

(3) Trip

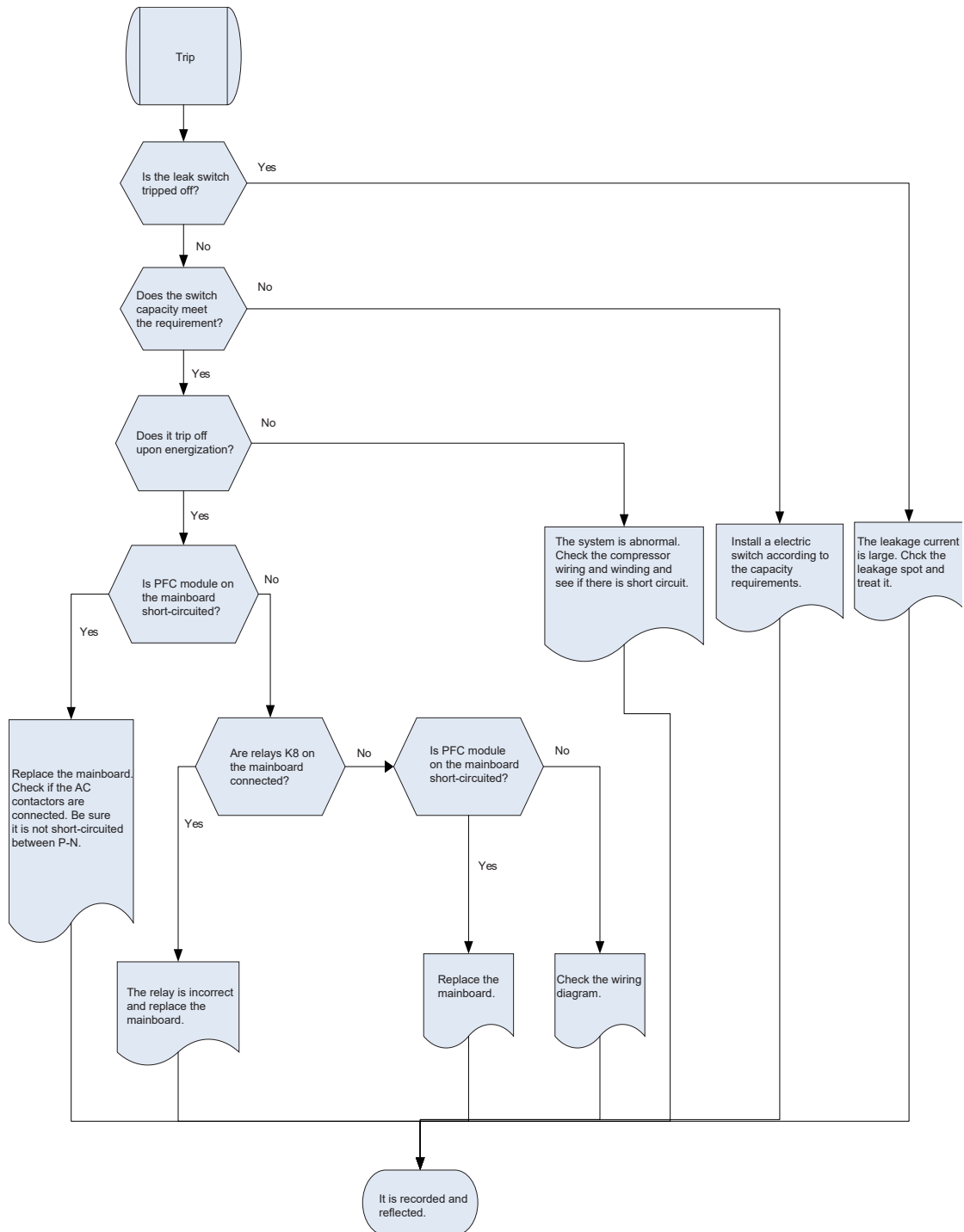



(4) Abnormal Noise of PFC Inductor

Generally, the continuous and minute sound of inductor is normal. Abnormal noise of PFC inductor refers to discontinuous and obvious noise. The reasons may be:

- PFC malfunction
- abnormal output of driving board

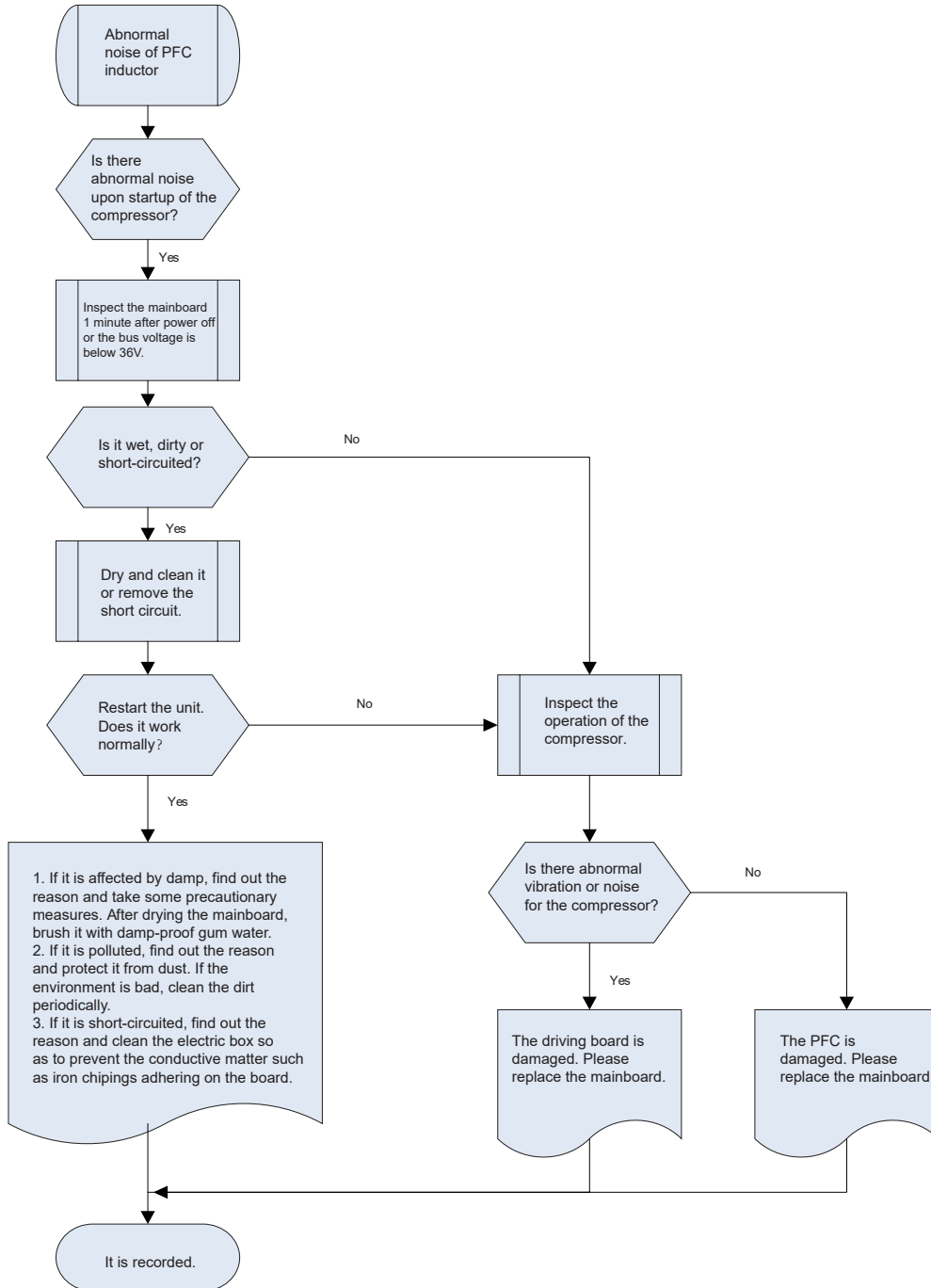

(5) Over-temperature Protection of Radiating Fin

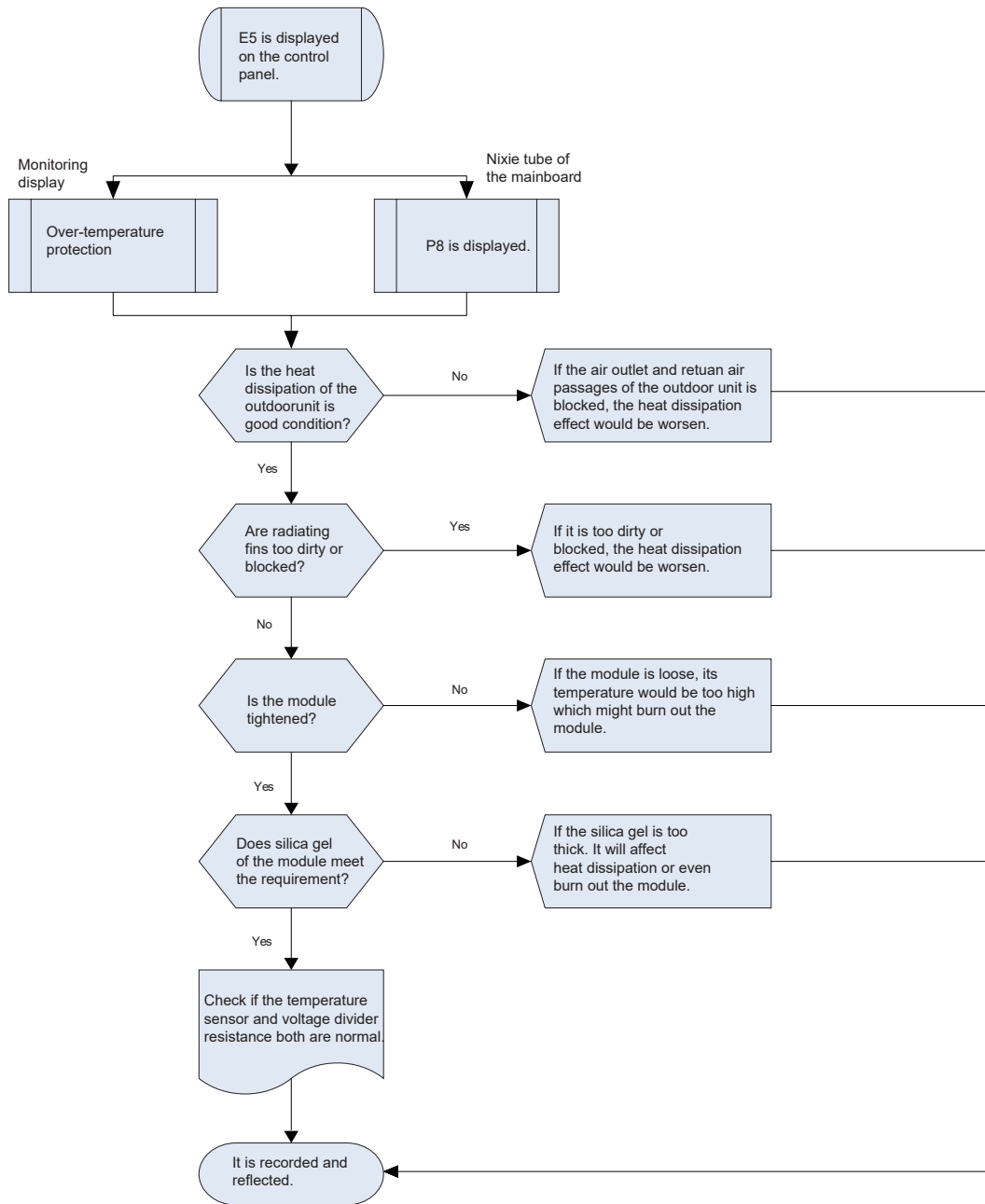

(6) Overvoltage protection of DC bus

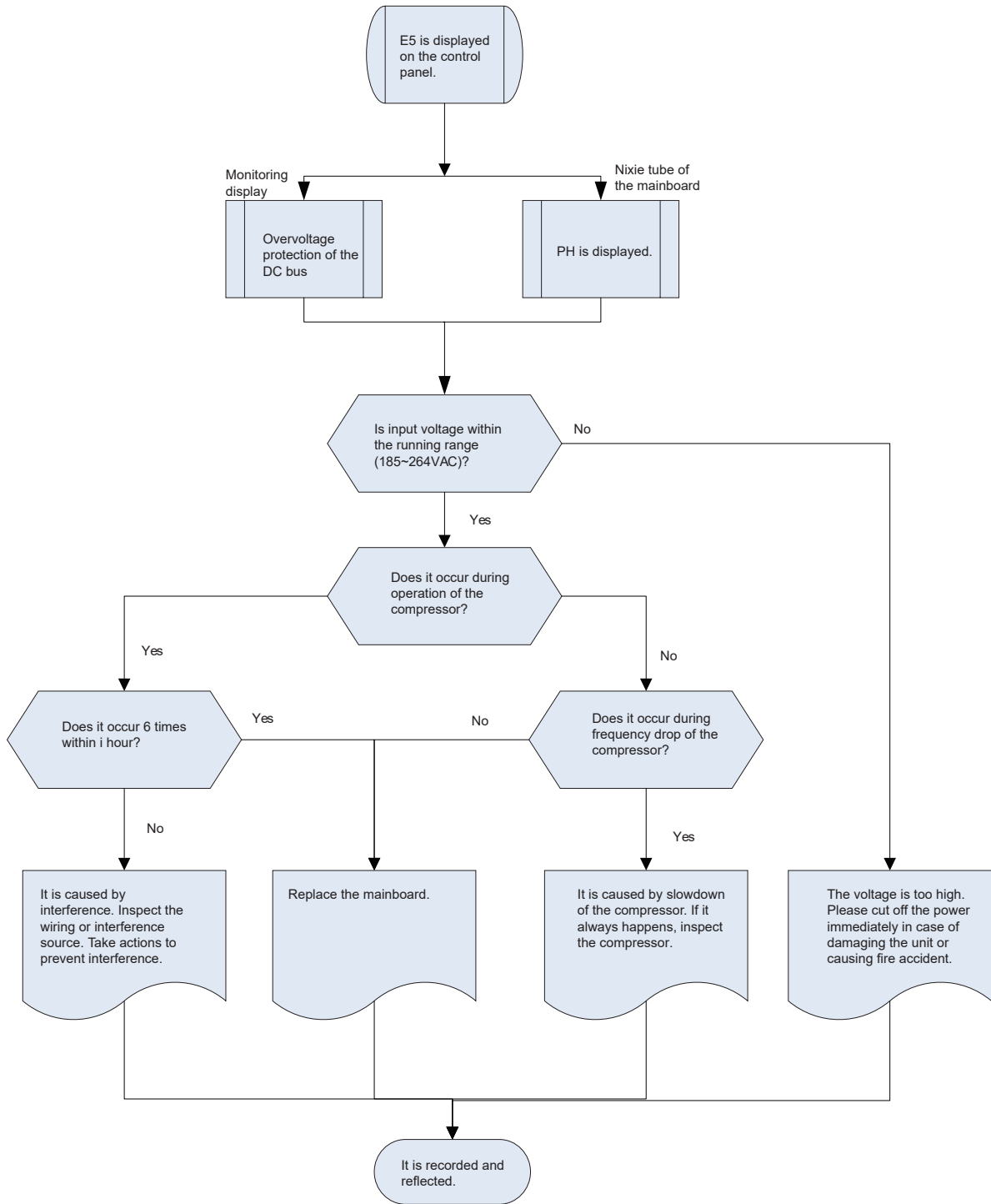

(7) Under-voltage Protection of DC bus

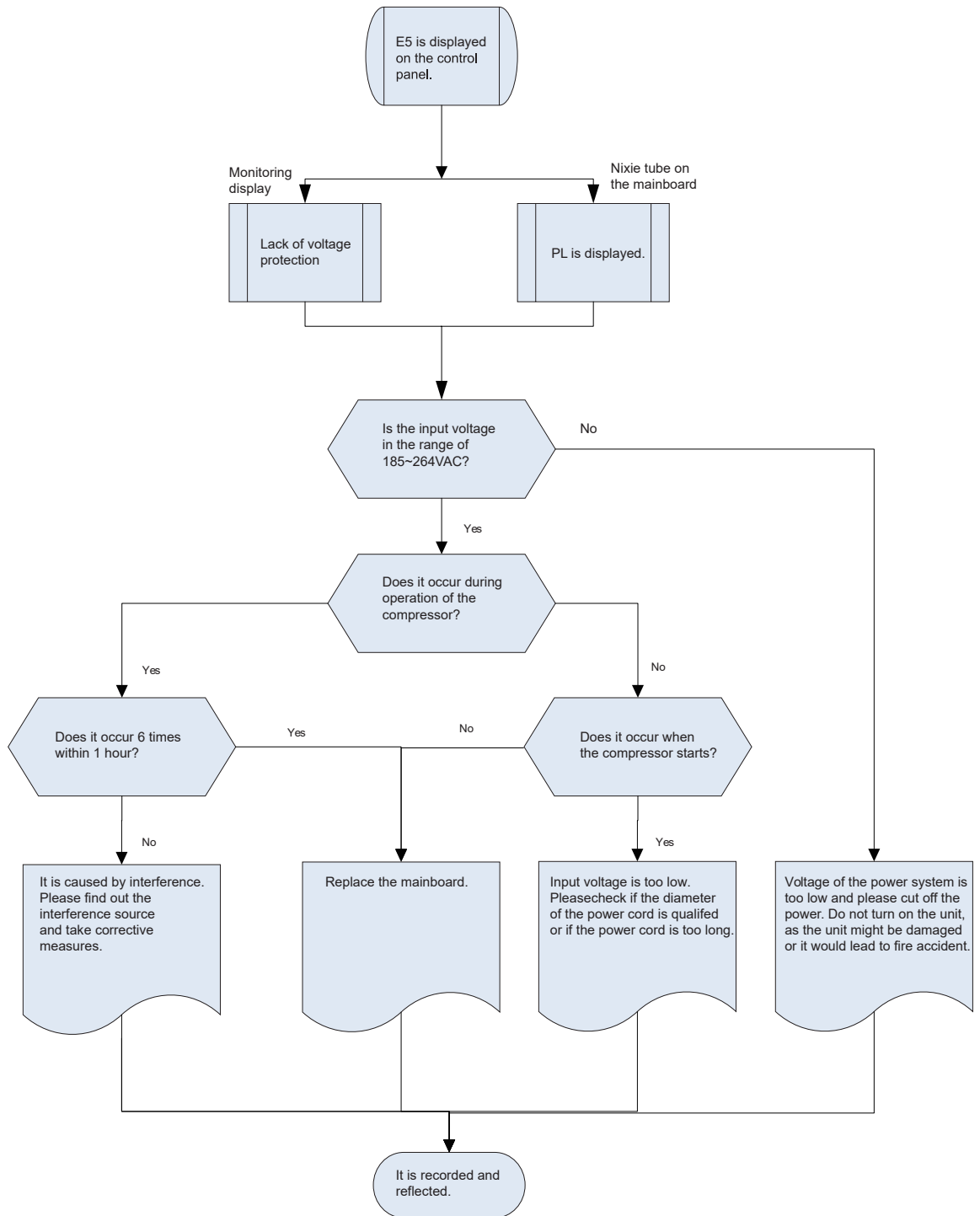

## 5 Disassembly of the Unit

Note: firstly please cut off the power supply and discharge refrigerant out of the unit.

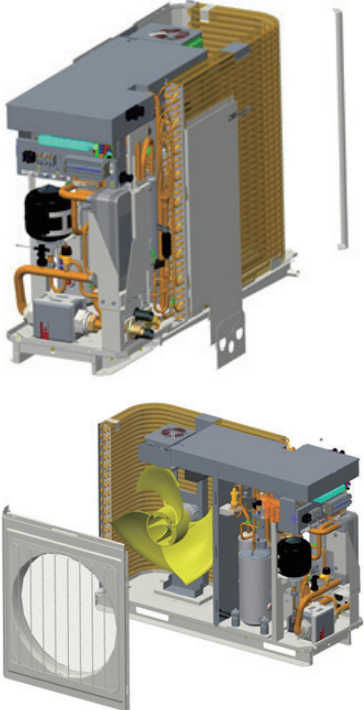
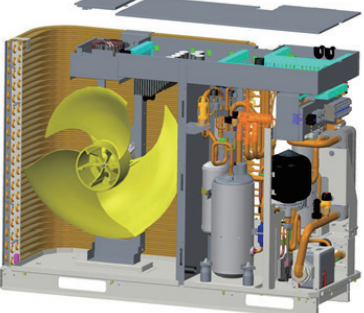
Operation Procedure	Illustration
<p>Remove the top panel, front panel and right panel.</p>	 <p>The illustration shows two stages of disassembly. The top part shows the complete unit with a yellow fan visible through the front panel. The bottom part shows the unit with the top panel, front panel, and right panel removed, revealing the internal components like the compressor, condenser, and evaporator.</p>
<p>Remove the fixing nuts and then the rear panel, connection panel and upright frame. Remove the fixing nuts and then the front grille.</p>	 <p>The illustration shows two stages of disassembly. The top part shows the unit with the rear panel, connection panel, and upright frame removed. The bottom part shows the unit with the front grille removed, revealing the internal components.</p>
<p>Remove the cover of both the electric box and the inductance box.</p>	 <p>The illustration shows the unit with the cover of the electric box and the inductance box removed, revealing the internal components.</p>

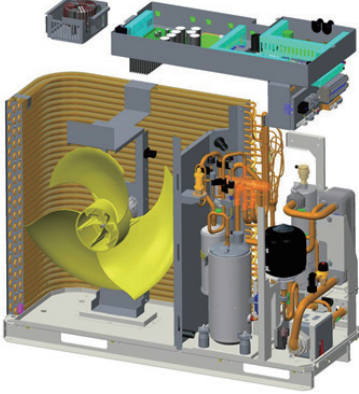
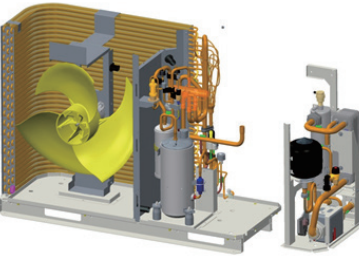
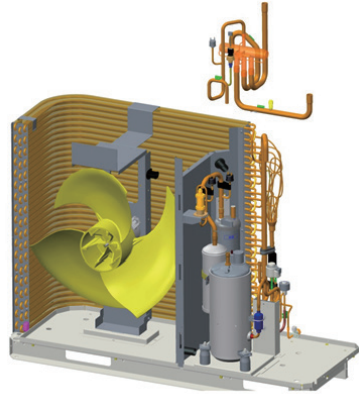
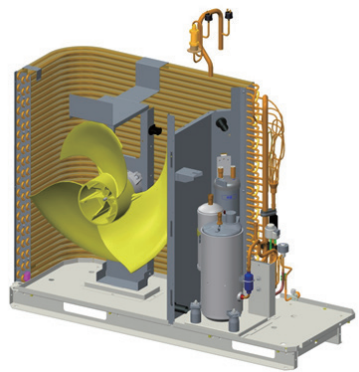
Note: firstly please cut off the power supply and discharge refrigerant out of the unit.	
Operation Procedure	Illustration
<p>Remove the electric box and the inductance box.</p>	
<p>Remove fastening bolts, desolder the joints between the plate heat exchanger gas/liquid pipe and the refrigerant system, and then remove the water system. (when desoldering the connection joint, pay attention to covering the solder joints with a damp cloth to avoid high temperature damage).</p>	
<p>Remove the 4-way valve.</p> <ul style="list-style-type: none"> <li>• Loosen the screws fixing the coil of 4-way valve</li> <li>• Remove the coil of 4-way valve</li> <li>• Unsolder the tubes connected to the 4-way valve.</li> <li>• Remove the 4-way valve.</li> <li>• Note:when desoldering the connection joint, pay attention to covering the solder joints with a damp cloth to avoid high temperature damage.</li> </ul>	
<p>Remove the suction line</p> <ul style="list-style-type: none"> <li>• Loosen the bolts fixing the gas valve.</li> <li>• desolder the line connected to the gas valve.</li> <li>• Note:when desoldering the connection joint, pay attention to covering the solder joints with a wet cloth to avoid high temperature damage.</li> </ul>	

Note: firstly please cut off the power supply and discharge refrigerant out of the unit.

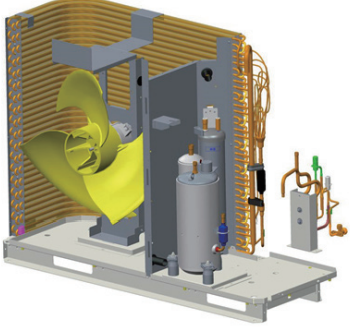
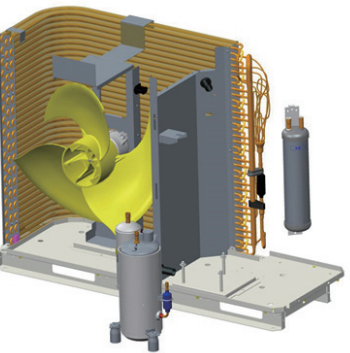
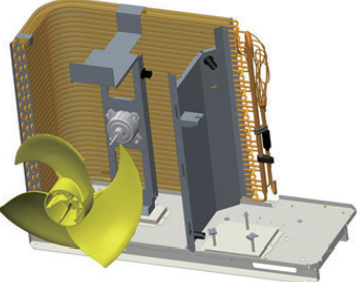
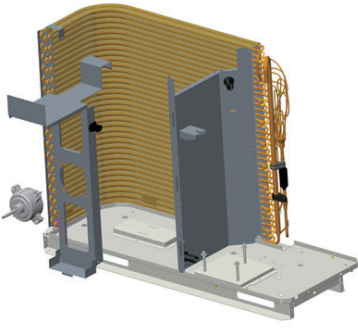
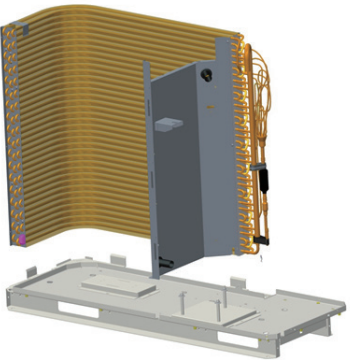
Operation Procedure	Illustration
<p>Remove the economizer</p> <ul style="list-style-type: none"> <li>• Loosen the bolts fixing the .</li> <li>• Unsolder the pipe connected to the liquid valve.</li> <li>• Note:when desoldering the connection joint, pay attention to covering the solder joints with a damp cloth to avoid high temperature damage.</li> </ul>	
<p>Remove compressor and gas-liquid separator</p> <ul style="list-style-type: none"> <li>• Remove the connection wire of compressor.</li> <li>• Unsolder the suction pipe and discharge pipe.</li> <li>• Loosen the bolts fixing the compressor and remove the compressor and gas-liquid separator.</li> </ul>	
<p>Remove the fitting bolts and the fan.</p>	
<p>Remove the fixing bolts at the motor and fitting nuts at the motor support, and then remove the motor and the motor support.</p>	
<p>Seperate the condenser from the base by removing fixing bolts at them.</p>	

## 6 Daily Maintenance and Repair

### 6.1 Daily Maintenance

In order to avoid damage of the unit, all protecting devices in the unit had been set before delivery, so please do not adjust or remove them.

For the first startup of the unit or next startup of unit after long-period stop (above 1 day) by cutting off the power, please electrify the unit in advance to preheat the unit for more than 8 hours.

Never put sundries on the unit and accessories. Keep dry, clean and ventilated around the unit.

Remove the dust accumulated on the condenser fin timely to ensure performance of the unit and to avoid stop of the unit for protection.

In order to avoid protection or damage of the unit caused by blockage of the water system, clean the filter in water system periodically and frequently check water replenishing device.

In order to ensure anti-freezing protection, never cut off the power if ambient temperature is below zero in winter.

In order to avoid frost crack of the unit, water in the unit and pipeline system not used for a long period should be drained. In addition, open the end cap of the water tank for drainage.

When the water tank has been installed but the water tank is set to "Without", functions relative with the water tank will not work and the displayed water tank temperature will always be "-30". In this case, the water tank would suffer frostbite and even other severe influences under low temperature. Therefore, once the water tank has been installed, the water tank must be set to "With", otherwise GREE will not be responsible for this abnormal operation.

Never frequently make the unit on/off and close the manual valve of the water system during operation of the unit by users.

Ensure frequent check to the working condition of each part to see if there is oil stain at pipeline joint and charge valve to avoid leakage of refrigerant.

If malfunction of the unit is out of control of users, please timely contact with authorized service center.

#### Notes

The water pressure gage is installed in the returning water line in the unit. Please adjust the hydraulics system pressure according to next item:

- (1) If the pressure is less than 0.5 bar, please recharge the water immediately.
- (2) When recharging, the hydraulics system pressure should be not more than 2.5 Bar.

Malfuctions	Reasons	Troubleshooting
Compressor does not start up	Power supply has problem. Connection wire is loose. Malfunction of mainboard. Malfunction of compressor.	Phase sequence is reverse. Check out and re-fix. Find out the reasons and repair. Replace compressor.
Heavy noise of fan	Fixing bolt of fan is loose. Fan blade touches shell or grill. Operation of fan is unreliable.	Re-fix fixing bolt of fan. Find out the reasons and adjust. Replace fan.
Heavy noise of compressor	Liquid slugging happens when liquid refrigerant enters into compressor. Internal parts in compressor are broken.	Check if expansion valve is failure and temp. sensor is loose. If that, repair it. Replace compressor.
Water pump does not run or runs abnormally	Malfunction of power supply or terminal. Malfunction of relay. There is air in water pipe.	Find out the reasons and repair. Replace relay. Evacuate.
Compressor starts or stops frequently	Poor or excess refrigerant. Poor circulation of water system. Low load.	Discharge or add part of refrigerant. Water system is blocked or there is air in it. Check water pump, valve and pipeline. Clean water filter or evacuate. Adjust the load or add accumulating devices.
The unit does not heat although compressor is running	Leakage of refrigerant. Malfunction of compressor.	Repair by leakage detection and add refrigerant. Replace compressor.



Malfunctions	Reasons	Troubleshooting
Poor efficiency of hot water heating	Poor heat insulation of water system. Poor heat exchange of evaporator. Poor refrigerant of unit. Blockage of heat exchanger at water side.	Enhance heat insulation efficiency of the system. Check if air in or out of unit is normal and clean evaporator of the unit. Check if refrigerant of unit leaks. Clean or replace heat exchanger.

## 6.2 Notice before seasonal use

- (1) Check whether air inlets and air outlets of the unit are blocked
- (2) Check whether ground connection is reliable or not
- (3) If unit starts up after not operating for a long time, it should be power on 8 hours before operation starts so as to preheat the compressor.
- (4) Precautions for Freeze Protection in Winter

Under subzero climatic conditions in winter, anti-freeze fluid must be added into the water cycle and external water pipes should be properly insulated. Glycol solution is recommended as the anti-freeze fluid.

When the unit is turned off for quite a long period and has been powered off, drain the water system to prevent the unit from suffering frostbites.





When the unit is turned off during seasonal use, do not power it off so that the freeze protection can be activated.







Concentration %	Freezing Temp °C	Concentration %	Freezing Temp °C	Concentration %	Freezing Temp °C
4.6	-2	19.8	-10	35	-21
8.4	-4	23.6	-13	38.8	-26
12.2	-5	27.4	-15	42.6	-29
16	-7	31.2	-17	46.4	-33

Note: "Concentration" listed in the table above indicates the mass concentration.

## 6.3 Repair

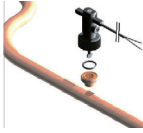
### 6.3.1 Key Components

Picture	Name	Function
	Compressor	It is the heart of the cooling system, mainly used to turn the low-temperature, low-pressure refrigerant vapor to high-temperature high-pressure vapor and then discharge it to the evaporator. The two-stage enthalpy-adding compressor is adopted herein, which can improve the heating performance of the unit largely.
	Electroic Expansion Valve	It is one of four main components and used to turn the hi-pressure liquid refrigerant to low-temperature, low-pressure vapor-liquid mixture and adjust the refrigerant flow rate entering the evaporator.
	Gas-liquid Separator	It is installed at the side of the suction line, and used to prevent liquid refrigerant entering the compressor, otherwise, the wet compression or the liquid slugging may occur.
	4-way Valve	It is used to switch flow direction of refrigerant and then realize switchover between cooling and heating. It also can be used for defrosting through the counterflow.

Picture	Name	Function
	Plate Heat Exchanger	It is the water-refrigerant plate type heat exchanger, used to liquefy the high-temperature high-pressure vapor refrigerant or evaporate the low-temperature low pressure liquid refrigerant. Heat of condensation is taken away by circulation water and heat for evaporation is supplied also by circulation water.
	Water Pump	It is the power equipment for water circulation.
	Expansion vessel	It is used to keep stable pressure of the water system. The tank is charged with a certain volume of nitrogen which is separated from the water side with a gasbag. When pressure of the water side exceeds the nitrogen pressure, the gasbag will expand and water enters into the tank so as to lower the pressure of the water system. In contract, when pressure of the water system goes down, nitrogen in the tank will expel water out to the water system.
	Flow Switch	It is used to prevent the heat exchanger from being frozen owing to reduced water flow rate. When the flow rate goes down to the point at which the flow switch will act, the switch will trip off and the unit will raise an alarm and shut down.
	Economizer	It is used in heating mode and water heating mode but NOT used in cooling mode. On one side, it can increase the subcooling before EXV, and on the other side it can improve the efficiency in heating circuit.
	Safety Valve	It is used to prevent the pressure of circulation water from increasing unusually. When the pressure is larger than the set point (0.3MPa), this valve will open to relieve water pressure.
	Exhaust Valve	It is used to expel air trapped inside the water system to make sure normal operation of the system. It is usually installed at the highest point of the system.

### 6.3.2 Charging and Discharging of Refrigerant

The unit has been charged with refrigerant before delivery. Overcharging or undercharging will cause the compressor to run improperly or be damaged. When refrigerant is required to be charged or discharged for installation, maintenance and other reasons, please follow steps below and nominal charged volume on the nameplate.

Discharging: remove metal sheets of the outer casing, connect a hose to the charging valve and then discharge refrigerant:

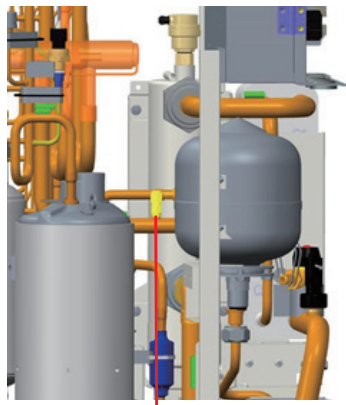

Charging valve 1

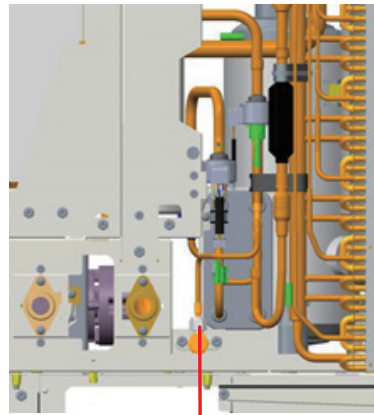

Charging valve 2

**NOTE**

- Discharge is allowed unless the unit has been stopped. (Cut off the power and repower it 1 minutes later)
- Protective measures should be taken during discharging to avoid frost bites.
- When discharging is finished, if vacuuming cannot be done immediately, remove the hose to avoid air or foreign matters entering the unit.
- Vacuuming: when discharging is finished, use hoses to connect the charging valve, manometer and vacuum pump to vacuum the unit.
- When vacuuming is finished, pressure inside the unit should be kept lower than 80Pa for at least 30 minutes to make sure there is no leak. Either charging valve 1 or charging valve 2 can be used for vacuuming.
- When vacuuming is finished and it is certain that there is no leak, charging can be done.

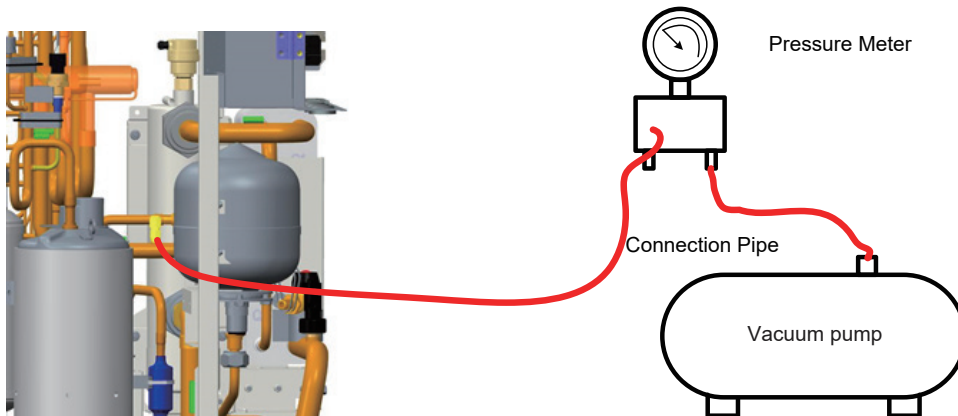

◆ Leak Detection Methods

The following leak detection methods are deemed acceptable for systems containing flammable refrigerants.

Electronic leak detector shall be used to detect flammable refrigerant, but the sensitivity may not be adequate, or may need re-calibration (Detection equipment shall be calibrated in a refrigerant-free area).

Ensure that the detector is not a potential source of ignition and is suitable for the refrigerant.

Leak detection equipment shall be set at a percentage of the LFL of the refrigerant and shall be calibrated to the refrigerant employed and the appropriate percentage of gas (25% maximum) is confirmed.

Leak detection fluids are suitable for us with most refrigerant but the use of detergents containing chlorine shall be avoided as the chlorine may react with the refrigerant and corrode the copper pipe-work.

If a leak is suspected, all naked flames shall be removed / extinguished. If a leakage of refrigerant is found which requires brazing, all of the refrigerant shall be recovered from the system, or isolated (by means of shut off valves) in a part of the system remote from the leak. Oxygen free nitrogen (OFN) shall then be purged through the system both before and during the brazing process.

Note: before and during operation, use an appropriate refrigerant leak detector to monitor the operation area and make sure the technicians can be well aware of any potential or actual leakage of inflammable gas. Make sure the leak detecting device is applicable to inflammable refrigerant. For example, it should be free of sparks, completely sealed and safe in nature.



SERVICE  
MANUAL

KRSCQ16HGD

