



Owner's Manual

Original Instructions

Air Handlers

Models:

KD24UHI

KD30UHI

KD36UHI

KD42UHI

KD48UHI

KD60UHI

Thank you for choosing this product. Please read this Owner's Manual carefully before operation and retain it for future reference.



To Users

Thank you for selecting KINGHOME product. Please read this instruction manual carefully before installing and using the product, so as to master and correctly use the product. In order to guide you to correctly install and use our product and achieve expected operating effect, we hereby instruct as below:

- (1) This appliance is not intended for use by persons (including children) with reduced physical, sensory or mental capabilities, or lack of experience and knowledge, unless they have been given supervision or instruction concerning use of the appliance by a person responsible for their safety. Children should be supervised to ensure that they do not play with the appliance.
- (2) In order to ensure reliability of product, the product may consume some power under stand-by status for maintaining normal communication of system and preheating refrigerant and lubricant. If the product is not to be used for long, cut off the power supply; please energize and preheat the unit in advance before reusing it.
- (3) Please properly select the model according to actual using environment, otherwise it may impact the using convenience.
- (4) This product can't be installed at corrosive, inflammable or explosive environment or the place with special requirements, such as kitchen. Otherwise, it will affect the normal operation or shorten the service life of the unit, or even cause fire hazard or serious injury. As for above special places, please adopt special air conditioner with anti-corrosive or anti-explosion function.
- (5) If the product needs to be installed, moved or maintained, please contact our designated dealer or local service center for professional support. Users should not disassemble or maintain the unit by themselves, otherwise it may cause relative damage, and our company will bear no responsibilities.
- (6) All the illustrations and information in the instruction manual are only for reference. In order to make the product better, we will continuously conduct improvement and innovation. If there is adjustment in the product, please subject to actual product.

Exception Clauses

Manufacturer will bear no responsibilities when personal injury or property loss is caused by the following reasons:

- (1) Damage the product due to improper use or misuse of the product.
- (2) Alter, change, maintain or use the product with other equipment without abiding by the instruction manual of manufacturer.
- (3) After verification, the defect of product is directly caused by corrosive gas.
- (4) After verification, defects are due to improper operation during transportation of product.
- (5) Operate, repair, maintain the unit without abiding by instruction manual or related regulations.
- (6) After verification, the problem or dispute is caused by the quality specification or performance of parts and components that produced by other manufacturers.
- (7) The damage is caused by natural calamities, bad using environment or force majeure.

Contents

1 Safety Precautions	1
2 Product Introduction	3
2.1 Product Description.....	3
2.2 Operating Range.....	3
2.3 Optional Accessories.....	3
2.4 Physical Dimension.....	3
2.5 Names of Main Parts.....	4
2.6 General Information	4
2.7 Dip Switch Configuration.....	5
2.8 Fan Performance Data.....	6
3 Preparative for Installation.....	10
3.1 Pre-Installation Instruction.....	10
3.2 Important Safety Instructions.....	10
4 Installation.....	12
4.1 Unit Inspection	12
4.2 Location	13
4.3 Piping Work.....	14
4.4 Condensate Removal.....	16
4.5 Ductwork.....	16
4.6 Electric Heater	17
4.7 Electrical Installation	19
5 Installation Check and Trial Run	29
5.1 Checking Items after Installation	29
5.2 Trial Run	29
6 Common Malfunction and Elimination	30
7 Maintenance and Care.....	32

7.1 Drain Pipe	32
7.2 Notice before Seasonal Use.....	32
7.3 Maintenance after Seasonal Use	32
7.4 Parts Replacement.....	32
8 After-Sales Service	33



1 Safety Precautions

WARNING

This product can't be installed at corrosive, inflammable or explosive environment or the place with special requirements, such as kitchen. Otherwise, it will affect the normal operation or shorten the service life of the unit, or even cause fire hazard or serious injury. As for above special places, please adopt special air conditioner with anti-corrosive or anti-explosion function.

Improper installation, adjustment, alteration, service, maintenance, or use can cause explosion, fire, electrical shock, or other conditions which may cause death, personal injury, or property damage. Consult a qualified installer, service agency, or your distributor or branch for information or assistance. The qualified installer or agency must use factory--authorized kits or accessories when modifying this product. Refer to the individual instructions packaged with the kits or accessories when installing. Follow all safety codes. Wear safety glasses, protective clothing, and work gloves. Use quenching cloth for brazing operations. Have fire extinguisher available. Read these instructions thoroughly and follow all warnings or cautions included in literature and attached to the unit. Consult local building codes and National Electrical Code (NEC) for special requirements. Recognize safety information. This is the safety--alert symbol .

When you see this symbol on the unit and in instructions or manuals, be alert to the potential for personal injury. Understand these signal words: **DANGER**, **WARNING**, **CAUTION** and **NOTICE**. These words are used with the safety--alert symbol.

- | | |
|--|---|
|  DANGER | Indicates a hazardous situation that, if not avoided, will result in death or serious injury. |
|  WARNING | Indicates a hazardous situation that, if not avoided, could result in death or serious injury. |
|  CAUTION | Indicates a hazardous situation that, if not avoided, may result in minor or moderate injury. |
| NOTICE | Indicates important but not hazard-related information, used to indicate risk of property damage. |

WARNING

Electrical shock hazard:

Failure to follow this warning could result in personal injury or death.

Before installing, modifying, or servicing system, main electrical disconnect switch must be in the OFF position. There may be more than 1 disconnect switch. Lock out and tag switch with a suitable warning label.

WARNING

PROPOSITION 65:

Respirable particles of fiberglass are known to State of California to cause cancer. This appliance contains fiberglass insulation.

California Proposition 65 warnings are required for certain products, which are not covered by the OSHA standards. All manufacturer products meet current federal OSHA Guidelines for safety.

Products that contain or produce any of the more than 600 listed chemicals known in California can cause cancer or birth defects, such as fiberglass insulation, lead in brass and natural gas combustion products. Warnings are issued for such products sold in California as required by California Proposition 65.

All “new equipment” shipped for sale in California will have labels stating that the product contains and /or produces Proposition 65 chemicals. We cannot always know “when, or if” products will be sold in the California market. Although we have not changed our processes, having the same label on all our products facilitates manufacturing and shipping.

WARNING

All phases of this installation must conform to NATIONAL, STATE AND LOCAL CODES. If it is required for additional information, please contact your local distributor.

WARNING

The unit must be permanently grounded. Failure to do so can lead to electrical shock causing personal injury or death.

WARNING

The material of plenum and ductwork must meet the standard NFPA 90B.

The supply air plenum or duct must have a solid sheet metal bottom piece directly after the air handler unit with no openings, registers or flexible air ducts located in it.

The first 6 inches of supply air plenum and ductwork must be constructed of sheet metal as required by NFPA 90B. Metal plenum or duct may be connected to the non-combustible floor base for downflow. Exposing combustible non-metal material to the supply opening of a downflow unit can cause a fire resulting in property damage, personal injury or death. If flexible supply air ducts are used they may be located only in the side walls of the rectangular plenum, a minimum of 6 inches from the solid bottom.

2 Product Introduction

2.1 Product Description

The KINGHOME air handler offer the perfect combination of superior product quality, operating efficiency, operating sound levels and value for money. The condensing unit uses the environmentally friendly refrigerant R410A, which is chlorine-free to help prevent damage to the ozone layer.

2.2 Operating Range

—	Cooling	Heating
Indoor temperature	64.4°F(18°C)~89.6°F (32°C)	50°F (10°C)~80.6°F (27°C)

2.3 Optional Accessories

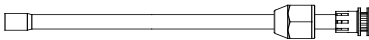
Indoor unit accessories				
No.	Name	Appearance	Q'ty	Usage
1	Throw-over pipe		1	Connect the unit with the liquid pipe

2.4 Physical Dimension

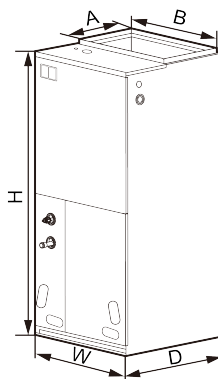

Model	Dimension				
	W	D	H	A	B
KD24UHI	18-1/8	21-1/4	43-1/2	11-5/8	16-3/4
KD30UHI	(460)	(540)	(1105)	(295)	(426)
KD36UHI	21-1/4	21-1/4	48-3/16	11-5/8	20
KD42UHI	(540)	(540)	(1224)	(295)	(508)
KD48UHI	24-13/16	21-1/4	52	11-5/8	20
KD60UHI	(630)	(540)	(1320)	(295)	(508)

NOTE: The outdoor unit models that can be matched with the indoor unit can be found on the AHRI website.

2.5 Names of Main Parts

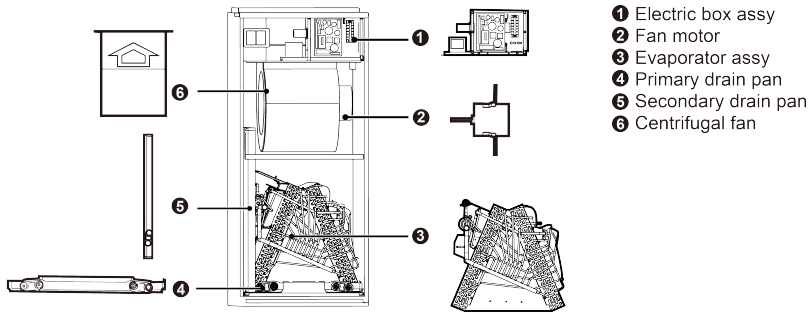

- ① Electric box assy
- ② Fan motor
- ③ Evaporator assy
- ④ Primary drain pan
- ⑤ Secondary drain pan
- ⑥ Centrifugal fan

2.6 General Information

Unit: mm

Model	Filter size
KD24UHI	420×516×15
KD30UHI	420×516×15
KD36UHI	490×516×15
KD42UHI	490×516×15
KD48UHI	525×516×15
KD60UHI	525×516×15

NOTES:

- ①. Based upon W/nominal tonnage, dry coil and filter should be installed.
- ②. Use 0.96 as approximate SCFM correction factor for wet coil.

2.7 Dip Switch Configuration

Set the indoor fan speed through the eight dip switches of the indoor main control board. The higher level, the higher speed of the indoor unit fan. Operation Instruction is below:

Dip switch settings must be completed before power on the unit.

After the unit is shut down or stopped at the temperature point, the indoor unit will delay for a few minutes and then shut down. The refrigeration can realize the drying function, relieve the mold of the air duct, and the heating can blow the waste heat and relieve the heat accumulation in the air duct.

During installation and debugging, pay attention to check whether the thermostat has set the fan delay and shutdown time. If the thermostat has been set, the actual delay and shutdown time of the fan is equal to the thermostat setting time plus the fan delay time of the indoor unit.

Model	Level	Heat (SA2)				Cool (SA1)			
KD24UHI	Level 1	1	0	0	0	0	0	0	0
	Level 2	1	0	0	1	0	0	0	0
	Level 3	1	0	1	0	0	0	0	0
	Level 4-Default	1	0	1	1	0	0	0	0
	Level 5	1	1	0	0	0	0	0	0
	Level 6	1	1	0	1	0	0	0	0
	Level 7	1	1	1	0	0	0	0	0
	Level 8	1	1	1	1	0	0	0	0
KD30UHI	Level 1	0	0	0	0	0	0	0	0
	Level 2	0	0	0	1	0	0	0	0
	Level 3	0	0	1	0	0	0	0	0
	Level 4-Default	0	0	1	1	0	0	0	0
	Level 5	0	1	0	0	0	0	0	0
	Level 6	0	1	0	1	0	0	0	0
	Level 7	0	1	1	0	0	0	0	0
	Level 8	0	1	1	1	0	0	0	0
KD36UHI	Level 1	1	0	0	0	0	0	0	0
	Level 2	1	0	0	1	0	0	0	0
	Level 3	1	0	1	0	0	0	0	0
	Level 4-Default	1	0	1	1	0	0	0	0
	Level 5	1	1	0	0	0	0	0	0
	Level 6	1	1	0	1	0	0	0	0
	Level 7	1	1	1	0	0	0	0	0
	Level 8	1	1	1	1	0	0	0	0

Model	Level	Heat (SA2)				Cool (SA1)			
KD42UHI	Level 1	0	0	0	0	0	0	0	0
	Level 2	0	0	0	1	0	0	0	0
	Level 3	0	0	1	0	0	0	0	0
	Level 4-Default	0	0	1	1	0	0	0	0
	Level 5	0	1	0	0	0	0	0	0
	Level 6	0	1	0	1	0	0	0	0
	Level 7	0	1	1	0	0	0	0	0
	Level 8	0	1	1	1	0	0	0	0
KD48UHI	Level 1	1	0	0	0	0	0	0	0
	Level 2	1	0	0	1	0	0	0	0
	Level 3	1	0	1	0	0	0	0	0
	Level 4	1	0	1	1	0	0	0	0
	Level 5	1	1	0	0	0	0	0	0
	Level 6-Default	1	1	0	1	0	0	0	0
	Level 7	1	1	1	0	0	0	0	0
	Level 8	1	1	1	1	0	0	0	0
KD60UHI	Level 1	0	0	0	0	0	0	0	0
	Level 2	0	0	0	1	0	0	0	0
	Level 3	0	0	1	0	0	0	0	0
	Level 4	0	0	1	1	0	0	0	0
	Level 5	0	1	0	0	0	0	0	0
	Level 6-Default	0	1	0	1	0	0	0	0
	Level 7	0	1	1	0	0	0	0	0
	Level 8	0	1	1	1	0	0	0	0

NOTE: 0 means dip switch to 'on', 1 means dip switch to number.

2.8 Fan Performance Data

External static pressure should stay within the minimum and maximum limits shown in the table below in order to ensure proper operation of both cooling and heating operation.

Model	KD24UHI											
Level	Static pressure:Inches W.C.(Pa)											
	0 (0)	0.1 (25)	0.15 (37)	0.2 (50)	0.3 (75)	0.4 (100)	0.5 (125)	0.6 (150)	0.7 (175)	0.8 (200)	0.9 (225)	1 (250)
Speed 1(CFM)	1030	900	-	-	-	-	-	-	-	-	-	-
Speed 2(CFM)	1080	960	900	-	-	-	-	-	-	-	-	-

Model	KD24UHI											
Level	Static pressure:Inches W.C.(Pa)											
	0 (0)	0.1 (25)	0.15 (37)	0.2 (50)	0.3 (75)	0.4 (100)	0.5 (125)	0.6 (150)	0.7 (175)	0.8 (200)	0.9 (225)	1 (250)
Speed 3(CFM)	1220	1120	1060	990	-	-	-	-	-	-	-	-
Speed 4(CFM)	1380	1250	1120	1070	1020	920	-	-	-	-	-	-
Speed 5(CFM)	1550	1490	1440	1390	1290	1180	1090	970	-	-	-	-
Speed 6(CFM)	1620	1540	1500	1450	1400	1360	1250	1130	960	-	-	-
Speed 7(CFM)	1700	1630	1580	1530	1450	1400	1370	1270	1150	970	-	-
Speed 8(CFM)	1750	1700	1650	1600	1590	1500	1420	1330	1200	1050	950	-

Model	KD30UHI											
Level	Static pressure:Inches W.C.(Pa)											
	0 (0)	0.1 (25)	0.15 (37)	0.2 (50)	0.3 (75)	0.4 (100)	0.5 (125)	0.6 (150)	0.7 (175)	0.8 (200)	0.9 (225)	1 (250)
Speed 1(CFM)	1110	980	-	-	-	-	-	-	-	-	-	-
Speed 2(CFM)	1160	1040	980	-	-	-	-	-	-	-	-	-
Speed 3(CFM)	1300	1200	1140	1070	-	-	-	-	-	-	-	-
Speed 4(CFM)	1460	1330	1200	1150	1100	1000	900	-	-	-	-	-
Speed 5(CFM)	1630	1570	1520	1470	1370	1260	1090	900	-	-	-	-
Speed 6(CFM)	1700	1620	1580	1530	1480	1440	1330	1210	1040	920	-	-
Speed 7(CFM)	1780	1710	1660	1610	1530	1480	1450	1350	1230	1130	960	-
Speed 8(CFM)	1800	1780	1730	1680	1670	1580	1500	1410	1280	1150	970	-

Air Handlers

Model	KD36UHI											
Level	Static pressure:Inches W.C.(Pa)											
	0 (0)	0.1 (25)	0.15 (37)	0.2 (50)	0.3 (75)	0.4 (100)	0.5 (125)	0.6 (150)	0.7 (175)	0.8 (200)	0.9 (225)	1 (250)
Speed 1(CFM)	1050	950	-	-	-	-	-	-	-	-	-	-
Speed 2(CFM)	1220	1120	1020	960	-	-	-	-	-	-	-	-
Speed 3(CFM)	1380	1260	1200	1100	950	-	-	-	-	-	-	-
Speed 4(CFM)	1630	1580	1500	1430	1370	1200	1050	970	-	-	-	-
Speed 5(CFM)	1710	1650	1600	1560	1480	1400	1250	1130	960	-	-	-
Speed 6(CFM)	1775	1725	1675	1635	1560	1495	1405	1315	1205	1040	-	-
Speed 7(CFM)	1840	1800	1750	1710	1640	1590	1500	1420	1330	1220	1100	930
Speed 8(CFM)	1870	1830	1810	1800	1760	1690	1620	1520	1440	1350	1250	1150

Model	KD42UHI											
Level	Static pressure:Inches W.C.(Pa)											
	0 (0)	0.1 (25)	0.15 (37)	0.2 (50)	0.3 (75)	0.4 (100)	0.5 (125)	0.6 (150)	0.7 (175)	0.8 (200)	0.9 (225)	1 (250)
Speed 1(CFM)	1100	1000	-	-	-	-	-	-	-	-	-	-
Speed 2(CFM)	1300	1200	1100	1010	-	-	-	-	-	-	-	-
Speed 3(CFM)	1380	1260	1200	1100	950	-	-	-	-	-	-	-
Speed 4(CFM)	1710	1650	1600	1560	1480	1400	1230	1150	1080	-	-	-
Speed 5(CFM)	1775	1725	1675	1635	1560	1495	1405	1315	1205	1075	-	-
Speed 6(CFM)	1840	1800	1750	1710	1640	1590	1500	1420	1330	1220	1080	900
Speed 7(CFM)	1870	1830	1810	1800	1760	1690	1620	1520	1440	1350	1250	1150
Speed 8(CFM)	1900	1860	1840	1830	1790	1720	1650	1550	1470	1380	1280	1180

Model	KD48UHI											
Level	Static pressure:Inches W.C.(Pa)											
	0 (0)	0.1 (25)	0.15 (37)	0.2 (50)	0.3 (75)	0.4 (100)	0.5 (125)	0.6 (150)	0.7 (175)	0.8 (200)	0.9 (225)	1 (250)
Speed 1(CFM)	1640	1500	-	-	-	-	-	-	-	-	-	-
Speed 2(CFM)	1680	1560	1500	-	-	-	-	-	-	-	-	-
Speed 3(CFM)	1810	1690	1620	1550	-	-	-	-	-	-	-	-
Speed 4(CFM)	1930	1830	1770	1710	1580	1480	-	-	-	-	-	-
Speed 5(CFM)	2200	2110	2040	1980	1860	1720	1620	1490	-	-	-	-
Speed 6(CFM)	2240	2190	2145	2100	2010	1870	1750	1615	1500	-	-	-
Speed 7(CFM)	2280	2240	2200	2180	2130	2080	2000	1880	1750	1600	-	-
Speed 8(CFM)	2300	2260	2220	2190	2140	2090	2040	1980	1930	1800	1700	1550

Model	KD60UHI											
Level	Static pressure:Inches W.C.(Pa)											
	0 (0)	0.1 (25)	0.15 (37)	0.2 (50)	0.3 (75)	0.4 (100)	0.5 (125)	0.6 (150)	0.7 (175)	0.8 (200)	0.9 (225)	1 (250)
Speed 1(CFM)	1660	1540	1470	-	-	-	-	-	-	-	-	-
Speed 2(CFM)	1850	1720	1650	1600	-	-	-	-	-	-	-	-
Speed 3(CFM)	1920	1800	1730	1650	1480	-	-	-	-	-	-	-
Speed 4(CFM)	2110	2000	1950	1860	1760	1640	1500	-	-	-	-	-
Speed 5(CFM)	2250	2200	2190	2140	2040	1930	1800	1670	1520	-	-	-
Speed 6(CFM)	2260	2220	2200	2170	2090	2010	1910	1760	1650	1550	-	-
Speed 7(CFM)	2300	2260	2230	2200	2150	2115	2050	1990	1920	1790	1650	1470
Speed 8(CFM)	2320	2280	2250	2230	2190	2140	2080	2040	2000	1950	1920	1890

NOTE: Please refer to above table for fan speed selection, and '-' indicates that the electric heater is not allowed to be used.

3 Preparative for Installation

3.1 Pre-Installation Instruction

3.1.1 Checking Product Received

After receiving the product, please check if there is any damage caused by transportation. Shipping damage is the responsibility of the carrier. Verify the model number, specifications and accessories are correct prior to installation. The distributor or manufacturer will not accept claims from dealers for transportation damage or installation of incorrectly shipped units.

3.1.2 Before Installation

Carefully read all instructions for the installation prior to installing product. Make sure each step or procedure is understood and any special considerations are taken into account before starting installation. Assemble all tools, hardware and supplies needed to complete the installation. Some items may need to be purchased locally. Make sure everything needed to install the product is on hand before starting.

3.1.3 Codes & Regulations

This product is designed and manufactured to comply with national codes. It is installer's responsibilities to install the product in accordance with such codes and/or any prevailing local codes/regulations. The manufacturer assumes no responsibilities for equipment installed in violation of any codes or regulations.

3.1.4 Replacement Parts

When reporting shortages or damages, or ordering repair parts, give the complete product model and serial numbers as stamped on the product. Replacement parts for this product are available through your contractor or local distributor.

3.2 Important Safety Instructions

Recognize safety symbols, words, and labels

The following symbols and labels are used throughout this manual to indicate immediate or potential hazards. It is the owner's responsibility to read and comply with all safety information and instructions accompanying these symbols. Failure to heed safety information increases the risk of serious personal injury or death, property damage and/or product damage.

⚠ DANGER Immediate hazards which will result in property damage, product damage, severe personal injury or death.

⚠ WARNING Hazards or unsafe practices could result in property damage, product damage, severe personal injury or death.

NOTICE Hazards or unsafe practices which may result in property damage, product damage, severe personal injury or death.

⚠ WARNING Before serving or installing this equipment. The electrical power to this unit must be in the “off” position. Caution, more than one disconnect may exist. Failure to observe this warning may result in an electrical shock that can cause personal injury or death.

⚠ WARNING

The United States Environmental Protection Agency (“EPA”) has issued various regulations regarding the introduction and disposal of refrigerants introduced into this unit. Failure to follow these regulations may harm the environment and can lead to the imposition of substantial fines. These regulations may vary due to the passage of laws. A certified technician must perform the installation and service of this product. Should questions arise, contact your local EPA office.

⚠ WARNING

Due to high system pressure and electrical shock in potential, installation and service work can be dangerous. Only trained and qualified persons are permitted to install or service this equipment. Observe all warnings contained in this manual and labels/tags attached to the equipment.

⚠ WARNING

This product is factory shipped for use with a 208/230V-1Ph-60Hz electrical power supply. This air handler must not be reconfigured to operate with any other power supply.

⚠ WARNING

The unit must have an uninterrupted, unbroken electric grounding to minimize the possibility of personal injury if an electric fault occurs. The electric grounding circuit may consist of an appropriate sized power cord which connected with the grounding piece located in the unit control box and also connecting to the building electric service panel.

Other methods of grounding are permitted if performed in accordance with the “National Electric Code” (NEC)/ “American National Standards Institute” (ANSI)/ “National Fire Protection Association” (NFPA) 70 and local/state codes. In Canada, electric grounding conforms to the Canadian electric code CSA c22.1. Failure to observe this warning can result in electrical shock that can cause personal injury.

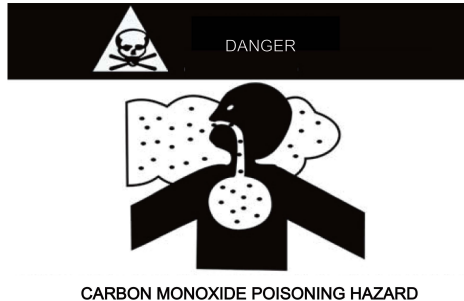

Special warning for installation of furnaces or air handling units in enclosed areas, such as garages, utility rooms or parking areas.

Carbon monoxide producing devices (such as an automobile, space heater, gas water heater, etc.) should not be operated in enclosed areas such as unventilated garages, utility rooms or parking areas because of the danger of carbon monoxide (CO) poisoning resulting from the exhaust emissions. If a furnace or air handler is installed in an enclosed area such as a garage, utility room or parking area and a carbon monoxide producing device is operated therein, there must be adequate ventilation directly to outside.

This ventilation is necessary to avoid the danger of CO poisoning which can occur if a carbon monoxide producing device continues to operate in the enclosed area. Carbon monoxide emission can be (re)circulated throughout the building if the furnace or air handler is operating in any mode.

CO can cause serious illness including permanent brain damage or death.

4 Installation

4.1 Unit Inspection

Upon delivery, inspect the unit for damage. Any damage must be reported immediately to the carrier. Do not install such an equipment damaged by freight which determines the integrity and safety of the unit.

Please check the equipment model number to ensure the unit is appropriately sized for the condensing unit.

If an incorrect unit is supplied, it must not be installed and it is to be returned to the supplier. The manufacturer assumes no responsibility for the installation of incorrectly delivered units. The evaporator coil contains high-pressure inert gas for holding charge.

4.2 Location

▲ WARNING This air handler is designed for indoor installation only. Do not install it outdoors.

When installing the air handler, take consideration to minimize the length of refrigerant tubing as much as possible. Do not install the air handler in a location either above or below the condenser that violates the instructions provided with the condenser. Service clearance is to take precedence. Allow a minimum of 24" in front of the unit for service clearance. When installing in an area directly over a finished ceiling (such as an attic), an emergency drain pan is required directly under the unit. See local and state codes for requirements. When installing this unit in an area that may become wet, elevate the unit with a sturdy, non-porous material. In installations that may lead to physical damage (i.e. a garage) it is advised to install a protective barrier to prevent such damage.

This air handler is designed for a complete supply and return ductwork system. Do not operate this product without all ductwork attached. The supply duct must be longer than 5 feet(1.524m).

Based upon the actual conditions, if air handler is installed as Fig. A, the air handler should be concealed in a specific room or space and make sure the air handler is not accessible to the general public.

Based upon the actual conditions, if air handler is installed as Fig. B, make sure that there is enough space for care and maintenance and the height between the air handler and ground is above 2500mm. And the air handler is not accessible to the general public. And the air handler should be maintained horizontal 5° angle to ensure smooth drainage.

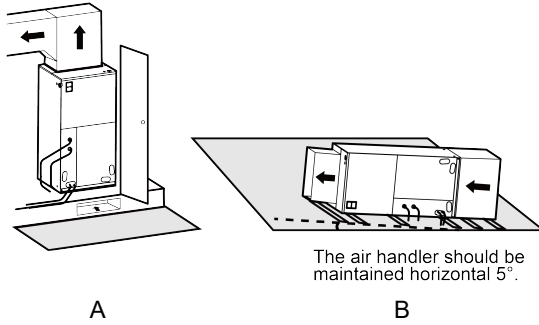

4.3 Piping Work

4.3.1 Specification of Connection Pipe

Model	External diameter (inch)	
	Gas pipe	Liquid pipe
KD24UHI KD30UHI KD36UHI KD42UHI KD48UHI KD60UHI	Φ3/4	Φ3/8

4.3.2 Piping Preparation

The gas pipe connection method adopts solder connection, the liquid pipe connection method is screw connection.

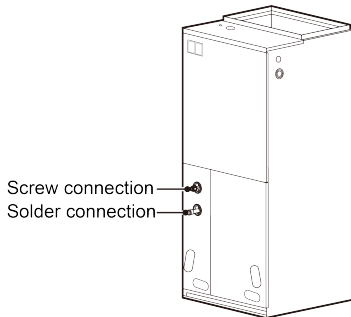

4.3.2.1 Solder Connection

All cut ends are to be round, burr free, and cleaned. Failure to follow this practice increases the chances for refrigerant leakage.

First, wrap the rubber grommet with water saturated cloth, and then weld off the cap closures from the gas pipes. Then weld the gas pipes with the connecting pipes.

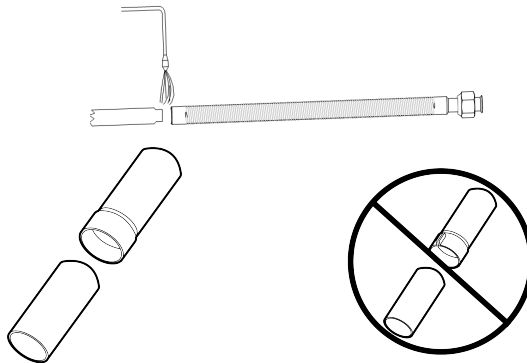
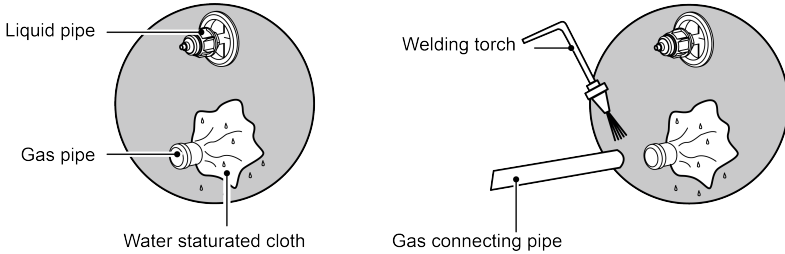

Line set size matches service valve connector

Do not crimp service valve connector when pipe is smaller than connector

4.3.2.2 Screw Connection

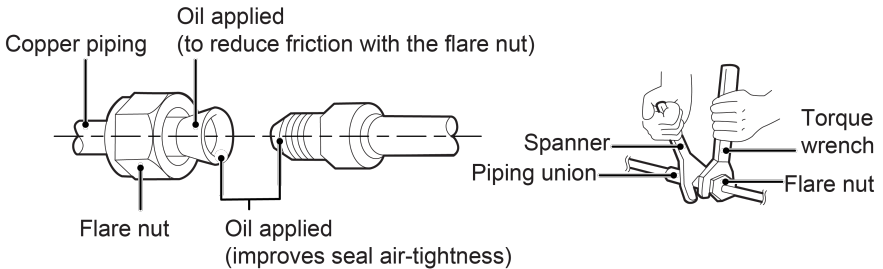

Pipe diameter (inch)	Tightening torque (N·m)
Φ1/4	15-30
Φ3/8	35-40
Φ1/2	45-50

Pipe diameter (inch)	Tightening torque (N·m)
Φ5/8	60-65
Φ3/4	70-75
Φ7/8	80-85

4.4 Condensate Removal

- (1) It is not allowed to connect the condensate drain pipe into waste pipe or other pipelines which are likely to produce corrosive or peculiar smell to prevent the smell from entering indoors or corrupt the unit.
- (2) It is not allowed to connect the condensate drain pipe into rain pipe to prevent rain water from pouring in and cause property loss or personal injury.
- (3) Condensate drain pipe should be connected into special drain system for air conditioner.
- (4) The drain pan has primary and secondary drain connection. Condensate removal is performed by attaching a 3/4" PVC pipe to the evaporator coil pan and terminated in accordance with local or state Plumbing/HVAC codes. The installation must include a "P" style trap that is located closely to the evaporator coil. Do not over-tighten the drain connection in order to prevent possible damage to the evaporator drain pan. See the following figure for details of a typical condensate line "P" trap.

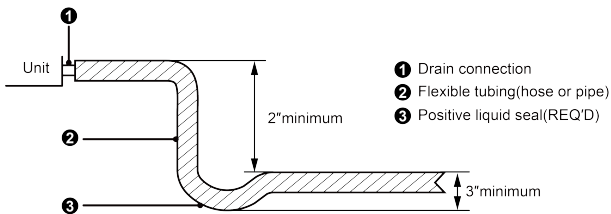

4.5 Ductwork

This air handler is designed for a complete supply and return ductwork system.

⚠ WARNING

Field ductwork must meet the National Fire Protection Association NFPA 90A, NFPA 90B and any applicable local ordinance.

Sheet metal ductwork run in unconditioned spaces must be insulated and covered with a vapor barrier. Fibrous ductwork may be used if constructed and installed in accordance with SMACNA Construction Standard on Fibrous Glass Ducts. Ductwork

must comply with National Fire Protection Association as tested by U/L Standard 181 for Class I Air Ducts. Check local codes for requirements on ductwork and insulation.

Duct system must be designed within the range of external static pressure the unit is designed to operate against. It is important that the system airflow be adequate. Make sure supply and return ductwork, grills, special filters, accessories, etc. are accounted for in total resistance. See fan performance data in this manual.

Do not operate the unit without all ductwork completed.

Do not operate this product without all ductwork attached.

Inadequate ductwork that restricts airflow can result in improper performance and compressor or heater failure. Ductwork is to be constructed in a manner that limits restrictions and maintains suitable air velocity. Ductwork is to be sealed to the unit in a manner that will prevent leakage.

Return ductwork: Do not terminate the return ductwork in an area that can introduce toxic or objectionable fumes/odors into the ductwork. The return ductwork is to be introduced into the air handler bottom (up flow configuration).

Return Air Filters: Each installation must include a return air filter. This filtering may be performed at the air handler or externally such as a return air filter grille.

4.6 Electric Heater

The air handlers listed in this manual do not have factory installed electric heat. Electric heat is available as an accessory. Please refer to installation instructions provided with heater kit for the correct installation procedure.

⚠ WARNING Refer to the “Electric heater kits installation” section of this manual and the instructions provided with the heater kit for the correct installation procedure.

⚠ WARNING The electrical characteristics of the air handler, the electric heater kit, and the supply power should be identical. This air handler does not have factory installed electric heater. Electric heater is available as an accessory. If installing this option, the only heater kits that can be used are the series as indicated below. It is forbidden to use the electric heater other than those recommended.

⚠ WARNING Installation and debugging when attention to verify the switch sequence of electrical heating and fan, ensure the fan must be turned on when electric heating operation and ensure the electric heating is turned off before the fan to avoid

unsafe.

⚠ WARNING Refer to the “Fan Performance Data” section of this manual, otherwise it is possible to cause an exception and dry risk of electric heating.

⚠ WARNING The supply ducts that are 5 feet away from electric heating must be at least 1 feet away from other combustibles or walls.

4.6.1 Electric Heater Kits Available

SN.	Kit	Description	Ref. air handler use(ton)
1	BLR 5000W/240V	Circuit breaker, 5kW heat strip	2.0/2.5/3.0/3.5/4.0/5.0
2	BLR 8000W/240V	Circuit breaker, 8kW heat strip	2.0/2.5/3.0/3.5/4.0/5.0
3	BLR 10000W/240V	Circuit breaker, 10kW heat strip	3.0/3.5/4.0/5.0
4	BLR 15000W/240V	Circuit breaker, 15kW heat strip	4.0/5.0
5	BLR 20000W/240V	Circuit breaker, 20kW heat strip	4.0/5.0

4.6.2 Electric Heater Kits Installation

⚠ CAUTION

- (1) Ensure that all power supply is disconnected prior to installing the heater kit.
- (2) A means of strain relief and conductor protection must be provided at the supply wire entrance into cabinet.
- (3) Use copper conductors only.
- (4) Installation must follow national electric code and other applicable codes.
- (5) If this appliance is installed in an enclosed area such as a garage or utility room with any carbon monoxide producing appliance, ensure the area is properly ventilated.
 - 1)Refer to the Table for appropriate heater kit.
 - 2)Check any physical damage, do not install damaged heater kit.
 - 3)Remove the upper access panel from air handler.
 - 4)Remove cover plate from air handler.
 - 5)Slide the heater kit in to the slot and secure element plate with previously removed screws.
 - 6)Insert power leads into the circuit breaker lugs or stripped red and black wires (for heater kit without circuit breaker) and tighten.

- 7) Connect ground wire to ground lug; M6 screws are required for grounding screws when installing electric heating.
- 8) Knock off appropriate area of the plastic circuit breaker cover on the access panel of the air handler. Knock off the holes according to the actual installation number and positions of circuit breakers. If circuit breaker is not installed, do not knock off the holes; otherwise, electric shock may occur.
- 9) Replace access panel and check operation.

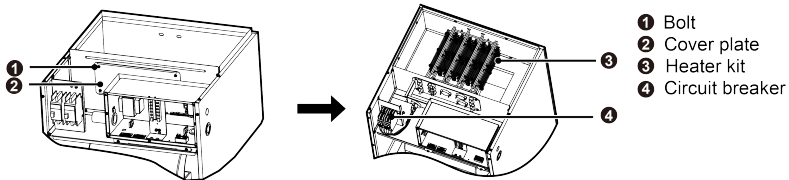

- 10) Connection of power cords and thermostat wires.

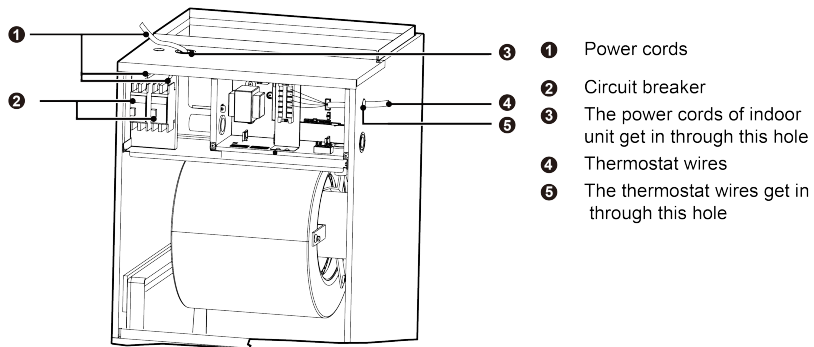

4.7 Electrical Installation

4.7.1 Requirement and Notice on Electrical Installation

⚠ WARNING

The electrical installation for the air conditioner should observe the following requirements:

- ① The electrical installation must be conducted by professionals in compliance with local laws and regulations and the instructions in this manual. Never extend the power cords. The electric circuit must be equipped with a circuit breaker and air switch both with sufficient capacity.

- ②. The unit's operating power must be within the nominal range stated in the instruction manual. Use a specialized power circuit for the air conditioner. Do not draw power from another power circuit.
- ③. The air conditioner circuit should be at least 1.5m away from any inflammable surface.
- ④. The external power cords, the thermostat wires and thermostat must be effectively fixed.
- ⑤. The external power cords, the thermostat wires and thermostat can't directly contact any hot objects. For example: they must not contact chimney pipes, warm gas pipes or other hot objects.
- ⑥. The external power cords, the thermostat wires and thermostat must not be squeezed. Never pull, stretch or bend the wires.
- ⑦. The external power cords, the thermostat wires and thermostat must not collide with any metal beam or edge on the ceiling, or touch any metal burrs or sharp metal edge around.
- ⑧. Connect wires correspondingly by referring to the circuit diagram labeled on the unit or electric box. Screws must be tightened up. Slipped screws must be replaced by specialized flat-head screws.
- ⑨. Please use the power cables that are delivered along with the air conditioner. Do not change the power cables arbitrarily. Do not change the length and terminals of the power cables. If you want to change the power cables, please contact KINGHOME's local service center.
- ⑩. Wiring terminals should be connected firmly to the terminal board. Loose connection is forbidden.
- ⑪. After the electrical installation is finished, please use wire clamps to secure the power cords and the thermostat wires. Make sure the wires are not clamped too tight.
- ⑫. The wire gauge of power cord should be large enough. Damaged power cords or other wires must be replaced by specialized wires. Wiring work must be done according to national wiring rules and regulations.

4.7.2 Electrical Parameters

Model	Power supply	Minimum circuit ampacity (A)	Maximum overcurrent protection (A)
KD24UHI	208/230V-1Ph-60Hz	3.5	15
KD30UHI		4.4	
KD36UHI		4.5	
KD42UHI		5.0	
KD48UHI		6.9	
KD60UHI		7.5	

NOTICE

- ①. Fuse is located on the main board.
- ②. Install a circuit breaker at every power terminal near the units (indoor unit and thermostat) with at least 3mm contact gap. The units must be able to be plugged or unplugged.
- ③. Circuit breaker and power cord specifications listed in the above table are determined based on the maximum power input of the units.
- ④. Specifications of circuit breaker are based on a working condition where the working temperature is 40°C. If working condition changes, please adjust the specifications according to national standards.
- ⑤. Adopt 5pc of AWG18 power cords to be the communication cords between indoor unit and thermostat. The maximum length is 30m. Please select a proper length according to local conditions. Communication cords must not be twisted together.
- ⑥. The wire gauge of communication cord should not be less than AWG18. It's recommended to use AWG18 power cords as the communication cords.

4.7.3 Connection of Power Cords and Thermostat Wires

- (1) For solid wires (as shown below):
 - 1) Use wire cutters to cut off the wire end and then peel away about 25mm of the insulation layer.
 - 2) Use a screwdriver to unscrew the terminal screw on the terminal board.
 - 3) Use nippers to bend the solid wire into a ring that fits the terminal screw.
 - 4) Form a proper ring and then put it on the terminal board. Use a screwdriver to tighten up the terminal screw.

(2) For strand wires (as shown below):

- 1) Use wire cutters to cut off the wire end and then peel away about 10mm of the insulation layer.
- 2) Use a screwdriver to unscrew the terminal screw on the terminal board.
- 3) Use a round terminal fastener or clamp to fix the round terminal firmly on the peeled wire end.
- 4) Locate the round terminal conduit. Use a screwdriver to replace it and tighten up the terminal screw (as shown below).

Unit:mm

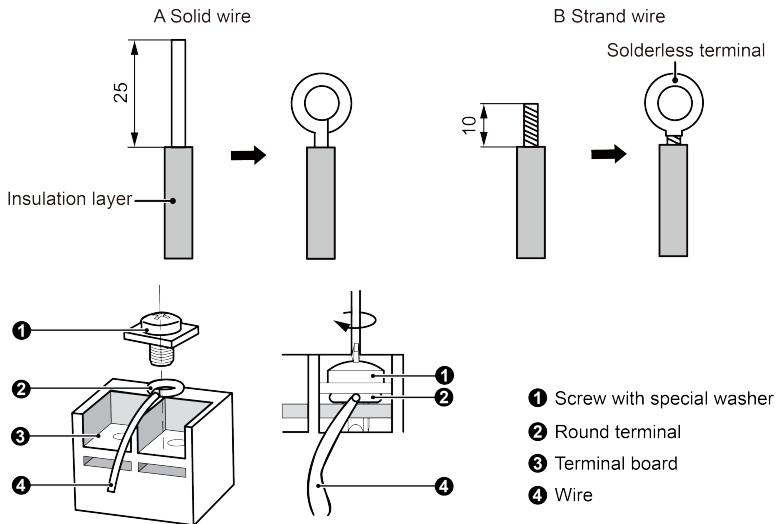

(3) How to connect the thermostat wires and power cords.

Lead the thermostat wires and power cords through the insulation tube. Then fix the wires with wire clamps (as shown in the following figure.)

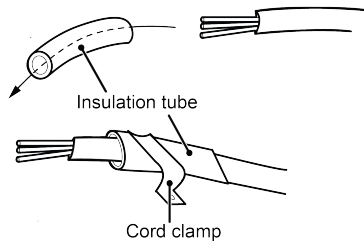

⚠ WARNING

- ①. Before working, please check whether the indoor unit and thermostat are

powered on.

- ②. Match the terminal numbers and wire colors with the colors indicated in the indoor unit.
- ③. Wrong wire connection may burn the electrical components.
- ④. Connect the wires firmly to the wiring box. Incomplete installation may lead to fire hazard.
- ⑤. Please use wire clamps to secure the external covers of connecting wires. (Insulators must be clamped securely; otherwise, electric leakage may occur.)
- ⑥. Ground wire should be connected.

Electrical wiring of indoor units (Only for air handler without electric heater)

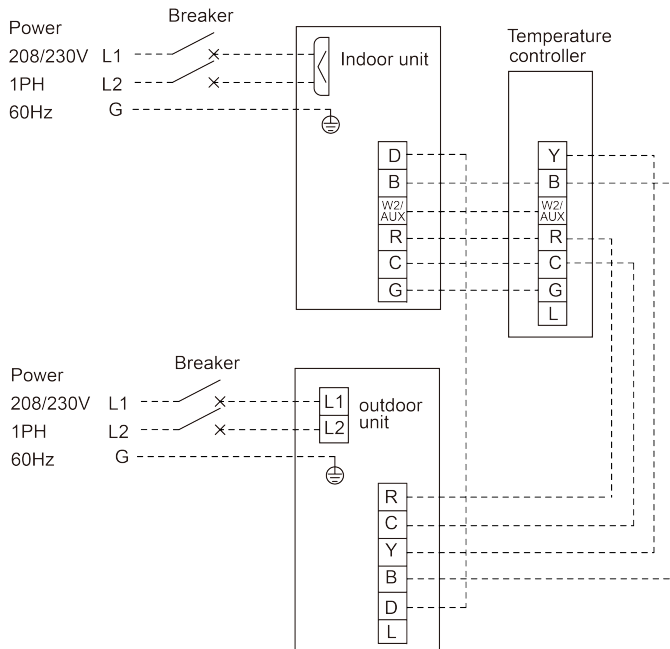

KD24UHI, KD30UHI, KD36UHI

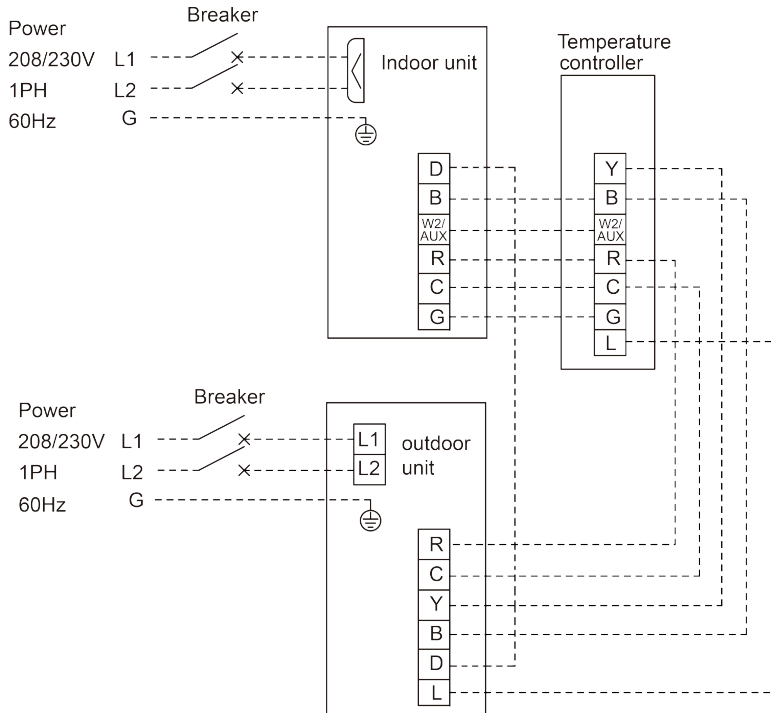

KD42UHI, KD48UHI, KD60UHI

Electrical wiring of indoor units (Only for air handler with electric heater)

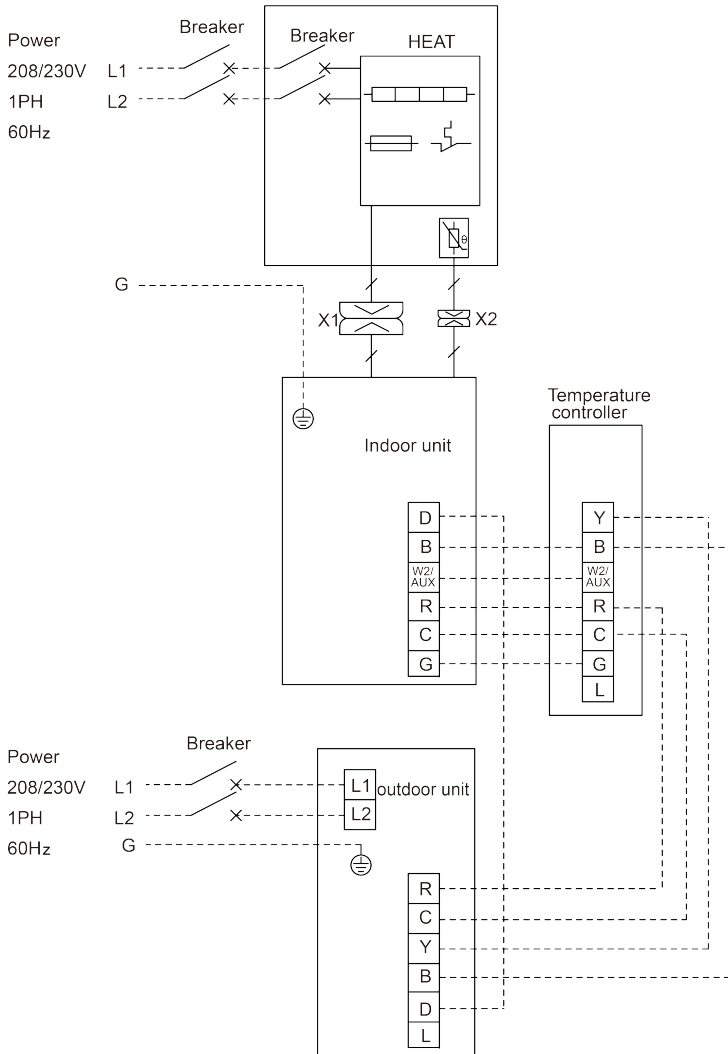

KD24UHI, KD30UHI, KD36UHI

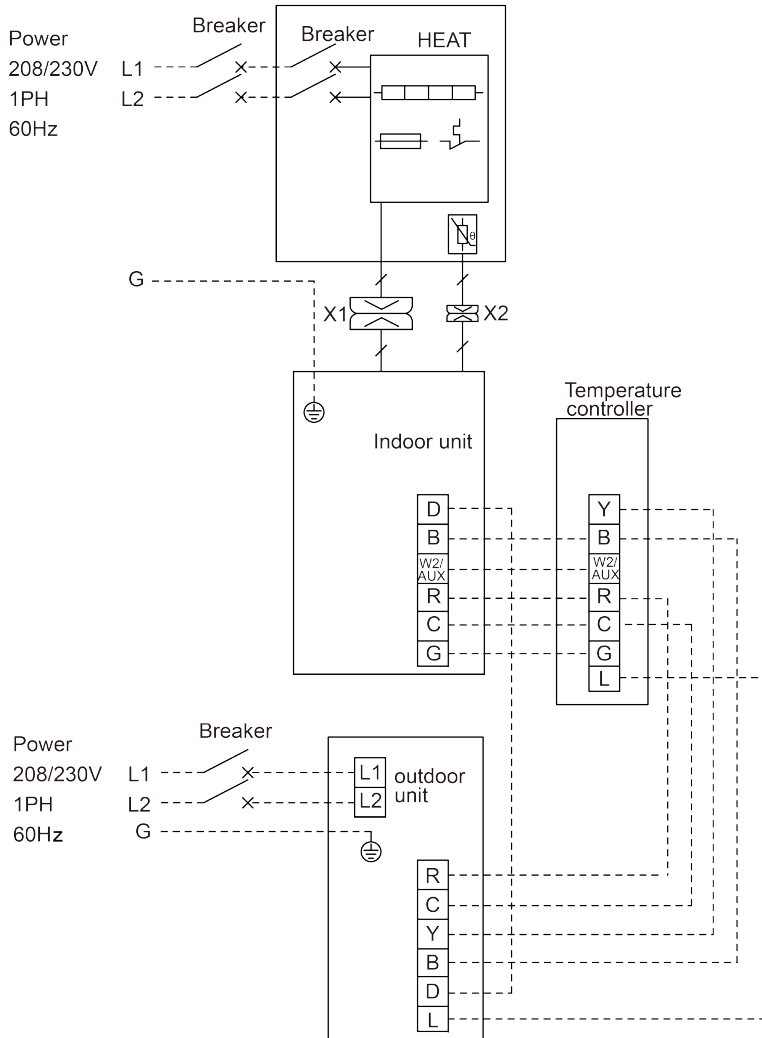

KD42UHI, KD48UHI, KD60UHI

(only for air handler with BLR 5000W/240V, BLR 8000W/240V or BLR 10000W/240V)

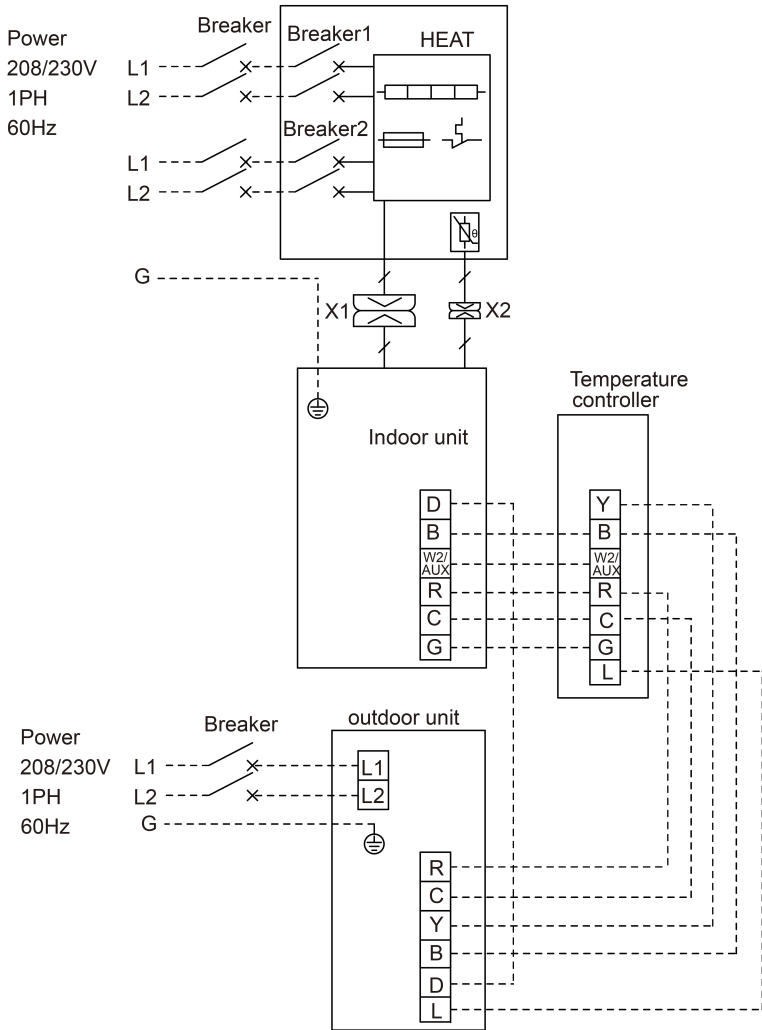

KD48UHI, KD60UHI

(only for air handler with BLR 15000W/240V or BLR 20000W/240V)

NOTE:

Y means Compressor control signal for the outdoor unit.

B which is energized under the heating mode means 4-way valve control signal.

D means defrosting signal.

R means 24V AC power supply.

C means 24V common.

G means indoor unit fan signal for the indoor unit.

W2/AUX means heater control signal.

L reserved function.

NOTE: For cooling only unit, there is no need to connect the B and D terminals.

NOTE: When outdoor defrosts, D of outdoor unit will send 24V signal to avoid cold winds.

NOTE: L reserved function, the wiring board does not pick up.

NOTE: Breaker must be incorporated in the fixed wiring in accordance with the wiring rules.

NOTE: When installing electric heating, M6 screws are required for grounding screws.

WARNING

- ①. High and low voltage wires should be led through different rubber rings of the electric box cover.
- ②. Do not bundle up the thermostat wires or lay them side by side, otherwise errors will occur.
- ③. High and low voltage wires should be secured separately. Secure the former ones with big clamps and the latter ones with small clamps.
- ④. Use screws to tighten up the thermostat wires and power cords of unit on the terminal board. Wrong connection may lead to fire hazard.
- ⑤. If the thermostat wires of unit and power cords are not correctly connected, the air conditioner may get damaged.
- ⑥. Ground the unit through connecting the ground wire.
- ⑦. The units should comply with applicable local and national rules and regulations on power consumption.
- ⑧. When connecting the power cords, make sure the phase sequence of the power supply matches with the corresponding terminals, otherwise the compressor will get reversed and operate abnormally.

5 Installation Check and Trial Run

5.1 Checking Items after Installation

Items to be checked	Problems might happen due to improper installation	Check
Check if each parts of the unit have been installed reliably.	The unit might fall off, vibrate or emit noise.	
Check if the unit has passed through leakage test.	It may cause deficiency of cooling (heating) capacity.	
Check if the unit has been insulated properly.	It may cause condensation and water drop.	
Check if the water can be drained fluently.	It may cause condensation and water drop.	
Check if the power voltage accords with that on the nameplate.	Malfunction might happen and parts might be burned.	
Check if the wiring and pipe line has been installed correctly.	Malfunction might happen and parts might be burned.	
Check if the unit has been earthed soundly.	Hazard of electricity leakage.	
Check if the wiring conforms to the wire gage.	Malfunction might happen and parts might be burned.	
Check if there is obstruction blocking the air inlet/outlet.	It may cause deficiency of cooling (heating) capacity.	
Check if the piping length and refrigeration charging volume has been recorded.	Uncertain about the refrigerant charging volume.	
Check if the piping connection and valves have been set properly.	It may cause unit abnormality and damage the unit.	
Make sure there is no crack among air return and supply pipe.	It may cause air leak, vibration and noise.	
Check if the panel is mounted firmly.	It may cause air leak, vibration and condensation.	

5.2 Trial Run

5.2.1 Preparative for Trial Run

- (1) Never power on the unit until all the installation work has been done.
- (2) All the control circuit and wiring has been connected correctly and soundly. Valves on the gas and liquid line should be completely open.

- (3) All the scattered objects should be removed, especially metal filing, thrum and clip.
- (4) Check if the unit appearance and piping system has been damaged during transportation or handling.
- (5) Check if the terminals are loose and the phases are correct.

5.2.2 Trial Run

- (1) Trial run can be operated by professional personnel only after above items have been checked (items to be checked as per actual condition).
- (2) Power on the unit and press ON/OFF button to activate.
- (3) After compressor starting up, please immediately stop the unit when abnormal sound emits.
- (4) Trial run under several modes and check if the unit operates normally.

6 Common Malfunction and Elimination

If the unit doesn't run normally, please check the following items before ask for service.

Phenomenon	Reason	Treatment
The unit can not be activated.	The unit doesn't connect with power supply.	Connect with power supply.
	Low voltage.	Check if circuit voltage is within rated scope.
	Fuse broken or breaker trips off.	Replace fuse or connect breaker.
The unit operates but stops immediately.	Air inlet/outlet of indoor unit is blocked.	Remove obstacles.
Abnormal cooling or heating.	Air inlet/outlet of indoor unit is blocked.	Remove obstacles.
	Inappropriate temperature setting.	Adjust setting at thermostat.
	Doors or windows are opened.	Close the door or windows.
	Direct sunshine.	Draw curtain or louver.
	Too much heat source in the room.	Reduce heat source.
	Filter screen is blocked by dirt.	Clean the filter.

NOTE: If reasons are still unclear after checking above items, please contact KINGHOME

service center and show phenomena and models.

Following circumstances are not malfunction.

“Malfunction”		Reason
Unit doesn't run.	When unit is started immediately after it is just turned off.	Overload protection switch makes it run after 3 minutes delay.
	When power is turned on.	Standby operating for about 1 minute.
Mist comes from the unit.	Under cooling.	Indoor high humidity air is cooled rapidly.
The unit emits noise.	Slight cracking sound is heard when just turned on.	It is noise when electronic expansion valve initialization.
	There is consecutive sound when cooling.	That's sound for gas refrigerant flowing in the unit.
	There is sound when unit starts or stops.	That's sound for gas refrigerant stops flowing.
	There is slight and consecutive sound when unit is running or after running.	That's sound for operation of drainage system.
The unit blows out dust.	When unit runs after no operation for a long period.	Dust in indoor unit is blew out.
The unit emits odor.	Operating.	The room odor absorbed by the unit is blew out again.
Indoor unit still runs after switch off.	After every indoor unit receive "stop" signal, fan will keep running.	Indoor fan can be set as "ON" or "AUTO" mode. Under "ON" mode, indoor fan will keep running after switch off the unit.

There are LED indicators on the main board of the indoor unit, which are used to display the operating status and malfunction information of the unit.

LED indicator	Color	Function
Power Indicator	Red	Indoor unit main board is powered on, Power Indicator is on.
Running Indicator	Green	After detecting the indoor fan turn-on signal, the running indicator light is on, when detecting the indoor fan turning-off signal, the running indicator light is off. When detecting a system failure, the running indicator light flashes.

Different running indicator flashing light means different system failure.

malfunction	Running Indicator status	Remark
Indoor Jumper cap failure	Light out 3S then flash once.	Flash means light on 0.5S then light out 0.5S.
Indoor fan failure	Light out 3S then flash twice.	
Indoor tube temperature sensor failure	Light out 3S then flash four times.	
Indoor air outlet temperature sensor failure	Light out 3S then flash six times.	

7 Maintenance and Care

Regular check, maintenance and care should be performed by professional personnel, which will prolong the unit life span.

7.1 Drain Pipe

Regularly check if the drain pipe is clogged in order to drain condensate smoothly.

7.2 Notice before Seasonal Use

- (1) Check if the inlet/outlet of the indoor unit is clogged.
- (2) Check if the ground wire is earthed reliably.
- (3) Check if the filter screen has been set soundly.
- (4) Check if the unit is installed firmly. If there is something abnormal, please contact the local appointed service center.

7.3 Maintenance after Seasonal Use

- (1) Cut off main power supply of the unit.
- (2) Clean filter screen of indoor units.
- (3) Clean the dust of sundries on the indoor units.
- (4) In the event of rusting, use the anti-rust paint to stop spreading of rust.

7.4 Parts Replacement

Purchase parts from local appointed service center or dealer if necessary. When user need to replace the mainboard, installer should put old mainboard jumper cap and the short-driven electrical resistance on the new mainboard. (If there is no short-driven electrical resistance put on the old motherboard, installer need not to replace short-driven electrical.)

8 After-Sales Service

In case the air-conditioning unit you bought has any quality problem or you have any inquiry, please contact the local after-sales service agency designated by factory.

Warranty should meet the following requirements:

- (1) First run of the unit should be operated by professional personnel from factory appointed service center.
- (2) Only factory manufactured accessories can be used on the machine.
- (3) All the instructions listed in this manual should be followed.
- (4) Warranty will be automatically invalid if fails to obey any item mentioned above.