



SPLIT TYPE

SAPPHIRE

Model :
 KW09HQ3D6DI
 KW09HQ3D6DO

#AHRI : 203493069



Item	Unit	Specification
ODU Model	-	KW09HQ3D6DO
IDU Model	-	KW09HQ3D6DI
System Ratings		
Cooling Capacity	Btu/h	9,000
Heating Capacity (47°F)	Btu/h	9,000
Heating Capacity (17°F)	Btu/h	8,000
Cooling Capacity Range	Btu/h	1,535-12,966
Heating Capacity Range	Btu/h	2,388-13,648
Cooling Power Input (Max)	W	1,400
Heating Power Input (Max)	W	1,500
SEER (SEER2)	-	38.00 (27)
HSPF (HSPF2)	-	15.00 (11)
EER	W/W	4.47
COP	W/W	4.32
Cooling Operation Range	°F(°C)	0~129.0 (-18.0~54.0)
Heating Operation Range	°F(°C)	-22~75.0 (-30.0~24.0)
Gas Pipe Size (OD)	Inch (MM)	1/2 (12)
Liquid Pipe Size (OD)	Inch (MM)	1/4 (6)
Connection Method	-	Flared
Factory Charge	oz	55.4
Additional Charge	oz/ft	0.2
Connection Pipe Length	ft.	25
Max Distance Length	ft.	49
Min Refrigerant Pipe Length	ft.	10
Max Distance Height	ft.	33
Indoor Unit Data		
Fan Motor Power Output	W	45
Fan Motor RLA	A	0.09
Air Flow Volume	CFM	424/383/353/324/294/265/206
Sound Pressure Level	dB(A)	46/40/38/36/33/31/19
Dehumidication	pt/hr	1.69
Power Supply	-	208/230V / 1Ph / 60Hz
Min/Max Voltage	V	187 - 253
MCA	A	-
MOCP/Breaker Size	A	-
Outdoor Unit Data		
Compressor Type	-	DC Inverter Rotary
Compressor RLA	A	6.9
Refrigerant Type	-	R410A
Fan Motor Power Output	W	30
Fan Motor RLA	A	0.28
Sound Pressure Level	dB(A)	57
Power Supply	-	208/230V / 1Ph / 60Hz
Min/Max Voltage	V	187 - 253
Main Supply Wire Size	-	16-3 AWG
MCA	A	9.0
MOCP/Breaker Size	A	15.0

Job Name:

Schedule Reference:

Date:

Specification are subject to change without notice.



Outline and Physical Dimension of KW09HQ3D6D.

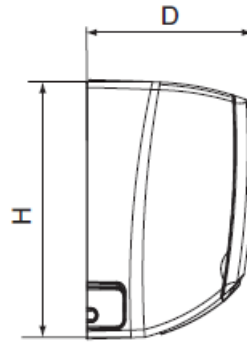
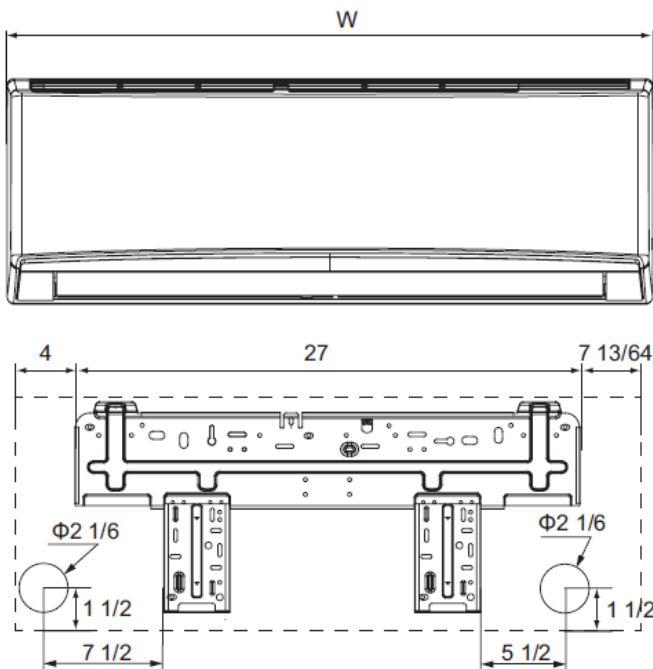

Units: inch (MM)

Dimensions	
W	38 13/64 (970)
H	11 13/16 (300)
D	8 5/6 (224)

Liquid Line Valve	1/4-in OD Flared
Gas Line Valve	1/2-in OD Flared
Drain Connector	5/8-in OD

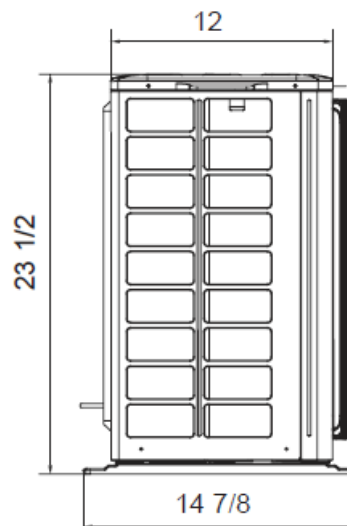
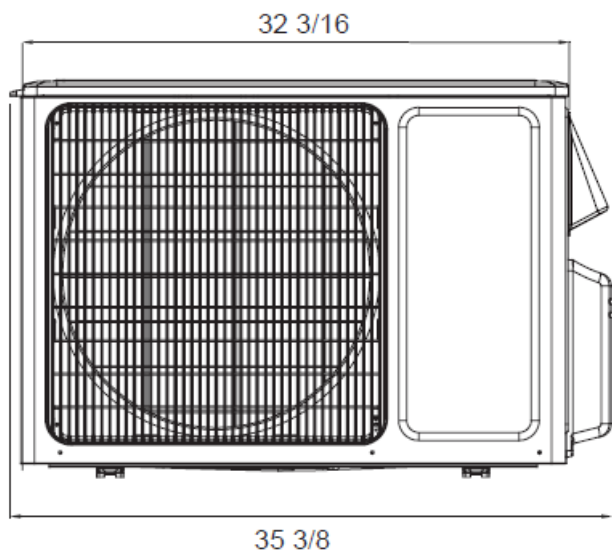

Units: inch (MM)

Dimensions	
W	35 5/8 (898)
H	23 1/2 (596)
D	14 7/8 (377)

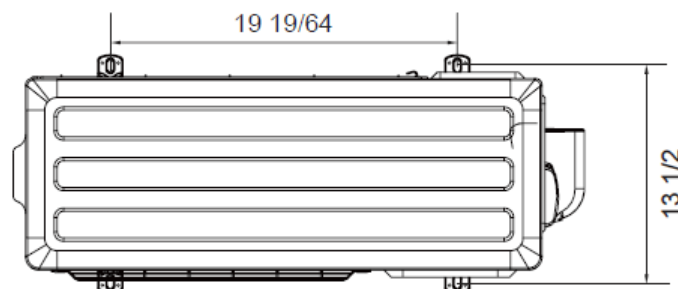

Liquid Line Valve	1/4-in OD Flared
Gas Line Valve	1/2-in OD Flared

Net Weight IDU	27.56 lb (12,5 kg)
Gross Weight IDU	34.17 lb (15,5 kg)
Net Weight ODU	99.2 lb (45 kg)
Gross Weight ODU	105.8 lb (48 kg)

