



SPLIT TYPE

SAPPHIRE

Model :
 KW24HQ3D6DI
 KW24HQ3D6DO

#AHRI : 203498481



Item	Unit	Specification
ODU Model	-	KW24HQ3D6DO
IDU Model	-	KW24HQ3D6DI
System Ratings		
Cooling Capacity	Btu/h	22,000
Heating Capacity (47°F)	Btu/h	24,000
Heating Capacity (17°F)	Btu/h	15,500
Cooling Capacity Range	Btu/h	6,800-30,700
Heating Capacity Range	Btu/h	6,800-32,000
Cooling Power Input (Max)	W	3,700
Heating Power Input (Max)	W	3,700
SEER (SEER2)	-	21.50 (21.5)
HSPF (HSPF2)	-	12.00 (9)
EER	W/W	3.81
COP	W/W	3.50
Cooling Operation Range	°F(°C)	0~129.0 (-18.0~54.0)
Heating Operation Range	°F(°C)	-22~75.0 (-30.0~24.0)
Gas Pipe Size (OD)	Inch (MM)	5/8 (16)
Liquid Pipe Size (OD)	Inch (MM)	1/4 (6)
Connection Method	-	Flared
Factory Charge	oz	81.1
Additional Charge	oz/ft	0.5
Connection Pipe Length	ft.	25
Max Distance Length	ft.	130
Min Refrigerant Pipe Length	ft.	10
Max Distance Height	ft.	65
Indoor Unit Data		
Fan Motor Power Output	W	60
Fan Motor RLA	A	0.24
Air Flow Volume	CFM	824/765/706/647/589/500/383
Sound Pressure Level	dB(A)	54/49/46/43/40/37/34
Dehumidication	pt/hr	4.23
Power Supply	-	208/230V / 1Ph / 60Hz
Min/Max Voltage	V	187 - 253
MCA	A	-
MOCP/Breaker Size	A	-
Outdoor Unit Data		
Compressor Type	-	DC Inverter Rotary
Compressor RLA	A	16.0
Refrigerant Type	-	R410A
Fan Motor Power Output	W	90
Fan Motor RLA	A	0.65
Sound Pressure Level	dB(A)	59
Power Supply	-	208/230V / 1Ph / 60Hz
Min/Max Voltage	V	187 - 253
Main Supply Wire Size	-	12-3 AWG
MCA	A	22
MOCP/Breaker Size	A	35

Job Name:

Schedule Reference:

Date:

Specification are subject to change without notice.



Outline and Physical Dimension of KW18HQ3D6D.

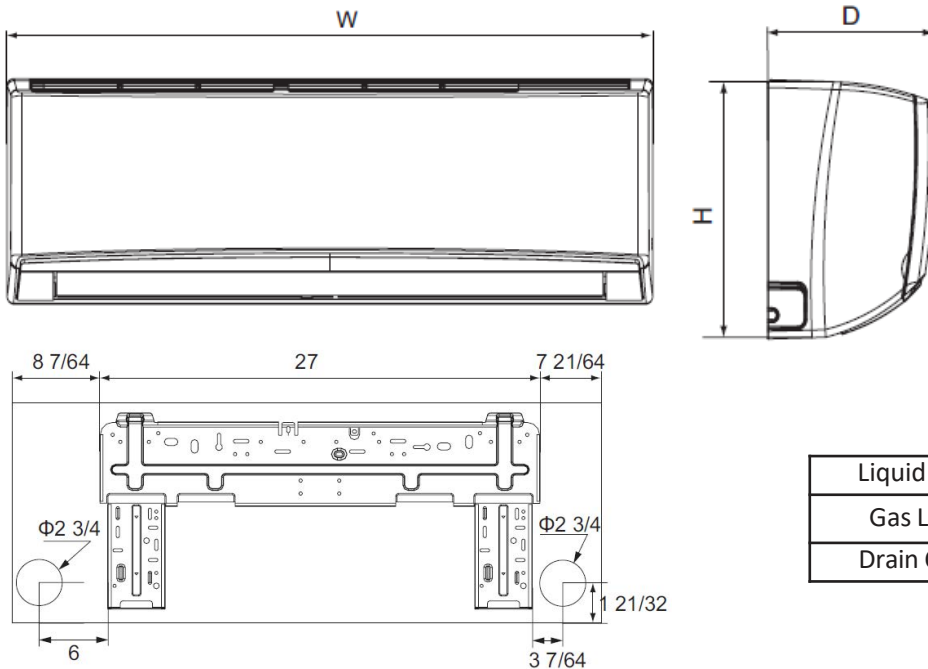

Units: inch (MM)

Dimensions	
W	42 7/16 (1052)
H	12 51/64 (325)
D	9 11/16 (246)

Liquid Line Valve	1/4-in OD Flared
Gas Line Valve	5/8-in OD Flared
Drain Connector	5/8-in OD

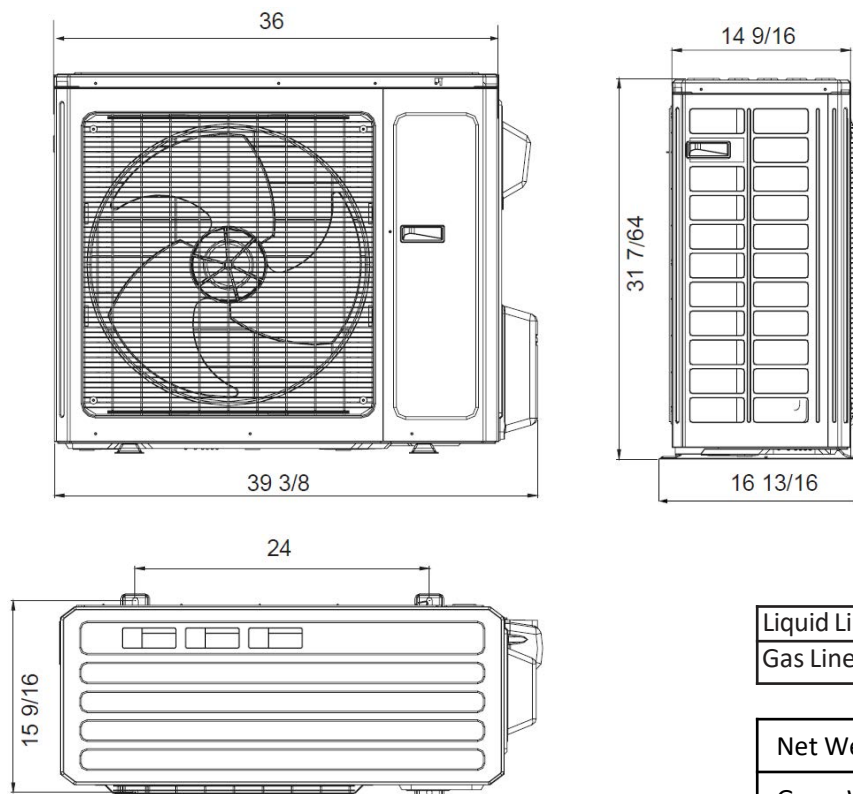

Units: inch (MM)

Dimensions	
W	39 3/8 (1000)
H	31 7/64 (790)
D	16 13/16 (427)

Liquid Line Valve	1/4-in OD Flared
Gas Line Valve	5/8-in OD Flared

Net Weight IDU	35.3 lb (16 kg)
Gross Weight IDU	43 lb (19,5 kg)
Net Weight ODU	141.1 lb (64 kg)
Gross Weight ODU	152.1 lb (68,9 kg)

