



SPLIT TYPE

SAPPHIRE

Model :
 KW18HQ3D6DI
 KW18HQ3D6DO

#AHRI : 203493071



Item	Unit	Specification
ODU Model	-	KW18HQ3D6DO
IDU Model	-	KW18HQ3D6DI
System Ratings		
Cooling Capacity	Btu/h	18,000
Heating Capacity (47°F)	Btu/h	18,000
Heating Capacity (17°F)	Btu/h	12,200
Cooling Capacity Range	Btu/h	4,094-21,836
Heating Capacity Range	Btu/h	4,094-24,566
Cooling Power Input (Max)	W	2,500
Heating Power Input (Max)	W	2,500
SEER (SEER2)	-	24.50 (22)
HSPF (HSPF2)	-	12.00 (10)
EER	W/W	3.97
COP	W/W	3.52
Cooling Operation Range	°F(°C)	0~129.0 (-18.0~54.0)
Heating Operation Range	°F(°C)	-22~75.0 (-30.0~24.0)
Gas Pipe Size (OD)	Inch (MM)	5/8 (16)
Liquid Pipe Size (OD)	Inch (MM)	1/4 (6)
Connection Method	-	Flared
Factory Charge	oz	70.6
Additional Charge	oz/ft	0.5
Connection Pipe Length	ft.	25
Max Distance Length	ft.	130
Min Refrigerant Pipe Length	ft.	10
Max Distance Height	ft.	65
Indoor Unit Data		
Fan Motor Power Output	W	60
Fan Motor RLA	A	0.24
Air Flow Volume	CFM	736/677/618/559/500/459/353
Sound Pressure Level	dB(A)	51/48/45/42/39/36/34
Dehumidification	pt/hr	3.80
Power Supply	-	208/230V / 1Ph / 60Hz
Min/Max Voltage	V	187 - 253
MCA	A	-
MOCP/Breaker Size	A	-
Outdoor Unit Data		
Compressor Type	-	DC Inverter Rotary
Compressor RLA	A	15.5
Refrigerant Type	-	R410A
Fan Motor Power Output	W	90
Fan Motor RLA	A	0.65
Sound Pressure Level	dB(A)	59
Power Supply	-	208/230V / 1Ph / 60Hz
Min/Max Voltage	V	187 - 253
Main Supply Wire Size	-	12-3 AWG
MCA	A	22
MOCP/Breaker Size	A	30

Job Name:

Schedule Reference:

Date:

Specification are subject to change without notice.



Outline and Physical Dimension of KW18HQ3D6D.

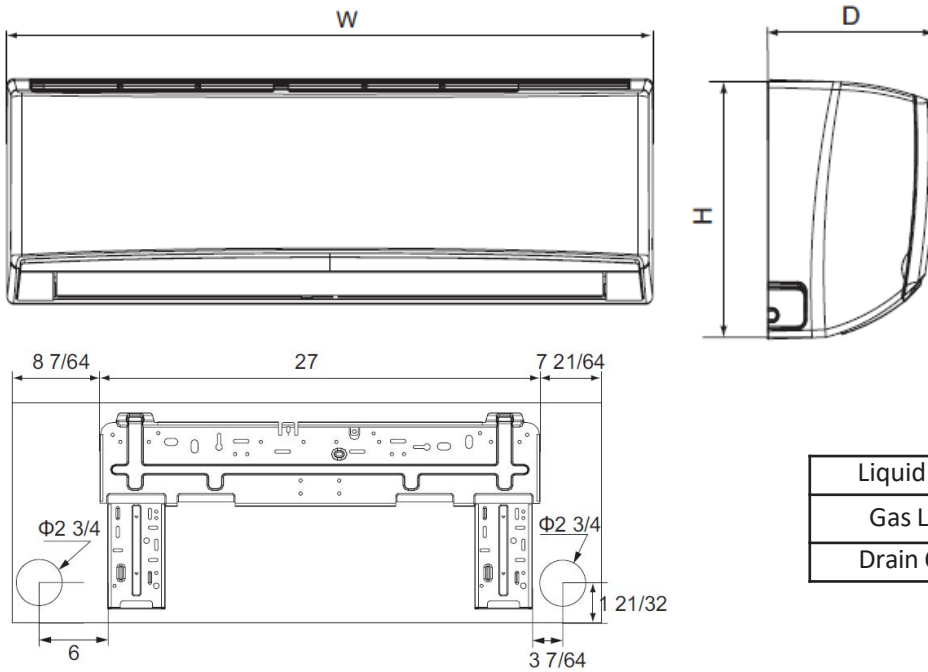

Units: inch (MM)

Dimensions	
W	42 7/16 (1052)
H	12 51/64 (325)
D	9 11/16 (246)

Liquid Line Valve	1/4-in OD Flared
Gas Line Valve	5/8-in OD Flared
Drain Connector	5/8-in OD

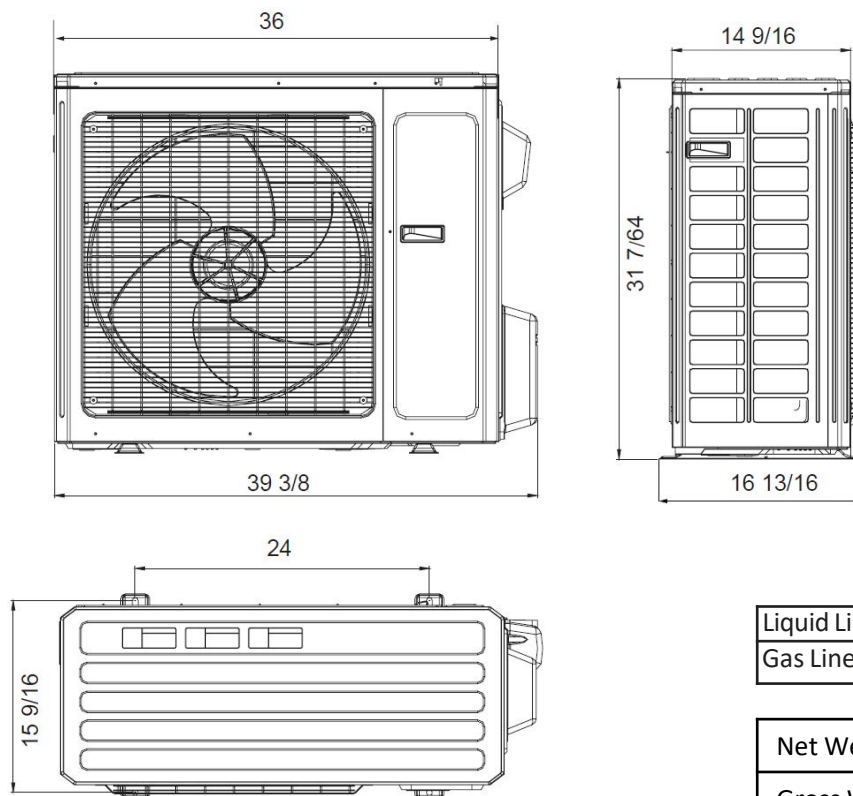

Units: inch (MM)

Dimensions	
W	39 3/8 (1000)
H	31 7/64 (790)
D	16 13/16 (427)

Liquid Line Valve	1/4-in OD Flared
Gas Line Valve	5/8-in OD Flared

Net Weight IDU	36.4 lb (16,5 kg)
Gross Weight IDU	44.1 lb (20 kg)
Net Weight ODU	141.1 lb (64 kg)
Gross Weight ODU	152.1 lb (68,9 kg)

