



**SPLIT TYPE**

**MULTI-ZONE**

**Model:  
KM36H50**



Item	Unit	Parameter
AHRI number	\	211497155
Outdoor Model	\	KM36H50
<b>System Rating</b>		
Cooling Capacity	Btu/h	34000
Heating Capacity	Btu/h	36000
Power Supply	\	208-230V/1Ph/60Hz
SEER2	\	21
EER2	\	3.52
HSPF2	\	10.00
Gas Pipe 1	inch (mm)	3/8 (9.52)
Liquid Pipe 1	inch (mm)	1/4 (6)
Gas Pipe 2	inch (mm)	3/8 (9.52)
Liquid Pipe 2	inch (mm)	1/4 (6)
Gas Pipe 3	inch (mm)	3/8 (9.52)
Liquid Pipe 3	inch (mm)	1/4 (6)
Gas Pipe 4	inch (mm)	3/8 (9.52)
Liquid Pipe 4	inch (mm)	1/4 (6)
Connection Pipe MAX. Height Distance (Indoor/Indoor)	ft (M)	82 (25)
Connection Pipe MAX. Height Distance (Indoor UP/Outdoor)	ft (M)	82 (25)
Connection Pipe MAX. Height Distance (Indoor/Outdoor UP)	ft (M)	82 (25)
MAX. Equivalent Connection Pipe Length (Outdoor/Last Indoor)	ft (M)	82 (25)
Connection Pipe MAX. Length Distance (Total Length)	ft (M)	262.5 (80)
Connection Method	\	Screw Connection
No Additionnal Gas Connection Pipe Length	ft (M)	131.2 (40)
Connection Pipe Length Additional Charge	oz/ft.	0.2
Refrigerant Type	\	R410A
Refrigerant Charge	oz	130.5
<b>Outdoor Unit Data</b>		
Sound Pressure Level	dB(A)	63
Min/Max Voltage	V	187-253
MCA	A	29
MOP	A	45
Dimension (HxWxD)	inch (mm)	32 1/2 x 40 3/16 x 16 13/16 (826 x 1020 x 427)
Dimension Package (HxWxD)	inch (mm)	34 1/4 x 42 15/16 x 19 7/16 (870 x 1090 x 494)
Net Weight	lb (Kg)	171.9 (78)
Gross Weight	lb (Kg)	187.4 (85)
Operating Temperature for Cooling	°F/°C	-22~118 (-30~48)
Operating Temperature for Heating	°F/°C	-22~75.2 (-30~24)



Specification are subject to change without notice.



**SPLIT TYPE**

**MULTI-ZONE**

**Model:  
KM36H50**

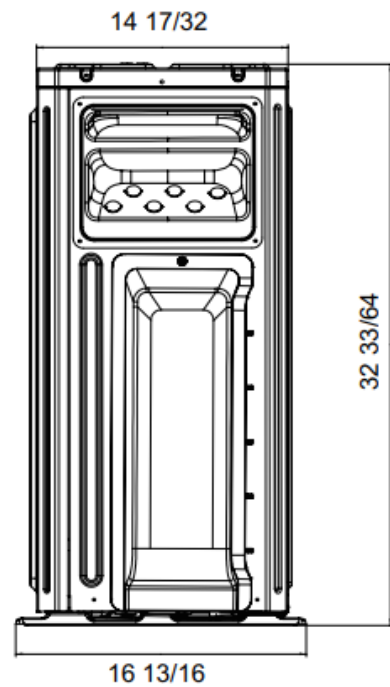
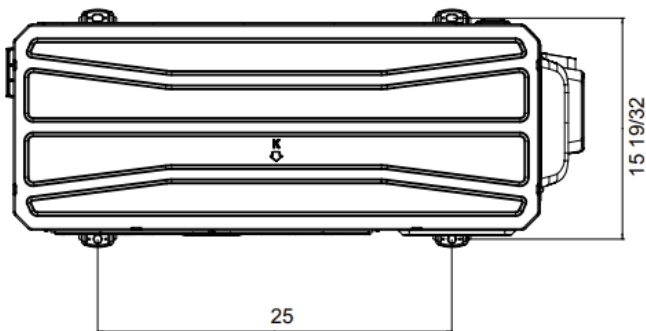
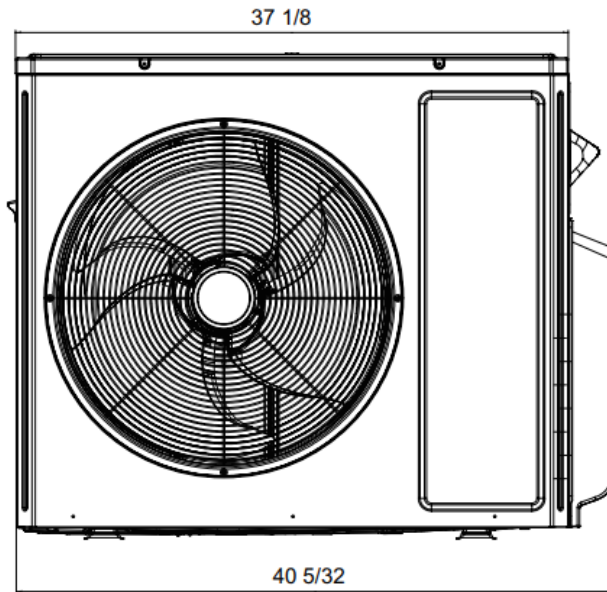

Specification are subject to change without notice.

Job Name:

Schedule Reference:

Date: