



SPLIT TYPE

MULTI-ZONE

**Model:
KM18H5O3**



Item	Unit	Parameter
AHRI number	\	214655286
Outdoor Model	\	KM18H5O3
System Rating		
Cooling Capacity	Btu/h	18000
Heating Capacity	Btu/h	19000
Power Supply	\	208-230V/1Ph/60Hz
SEER2	\	21
EER2	\	3.52
HSPF2	\	10.00
Gas Pipe 1	inch (mm)	3/8 (9.52)
Liquid Pipe 1	inch (mm)	1/4 (6)
Gas Pipe 2	inch (mm)	3/8 (9.52)
Liquid Pipe 2	inch (mm)	1/4 (6)
Gas Pipe 3	inch (mm)	3/8 (9.52)
Liquid Pipe 3	inch (mm)	1/4 (6)
Connection Pipe MAX. Height Distance (Indoor/Indoor)	ft (M)	49.2 (15)
Connection Pipe MAX. Height Distance (Indoor UP/Outdoor)	ft (M)	49.2 (15)
Connection Pipe MAX. Height Distance (Indoor/Outdoor UP)	ft (M)	49.2 (15)
MAX. Equivalent Connection Pipe Length (Outdoor/Last Indoor)	ft (M)	65.6 (20)
Connection Pipe MAX. Length Distance (Total Length)	ft (M)	131.2 (40)
Connection Method	\	Screw Connection
No Additionnal Gas Connection Pipe Length	ft (M)	32.8 (10)
Connection Pipe Length Additional Charge	oz/ft.	0.2
Refrigerant Type	\	R410A
Refrigerant Charge	oz	45.9
Outdoor Unit Data		
Sound Pressure Level	dB(A)	53
Min/Max Voltage	V	187-253
MCA	A	15
MOP	A	20
Dimension (HxWxD)	inch (mm)	21 5/8 x 32 3/8 x 13 7/8 (550 x 822 x 352)
Dimension Package (HxWxD)	inch (mm)	23 3/8 x 34 3/16 x 15 9/16 (594 x 869 x 395)
Net Weight	lb (Kg)	78.3 (35.5)
Gross Weight	lb (Kg)	83.8 (38)
Operating Temperature for Cooling	°F/°C	-22~118 (-30~48)
Operating Temperature for Heating	°F/°C	-22~75.2 (-30~24)



Specification are subject to change without notice.



SPLIT TYPE

MULTI-ZONE

**Model:
KM18H503**

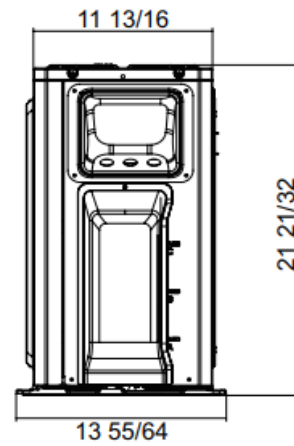
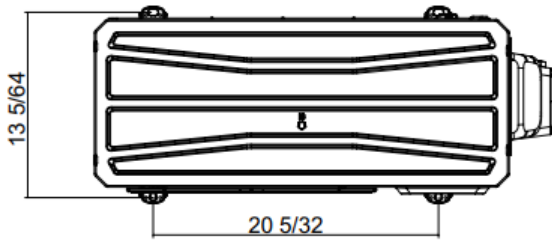
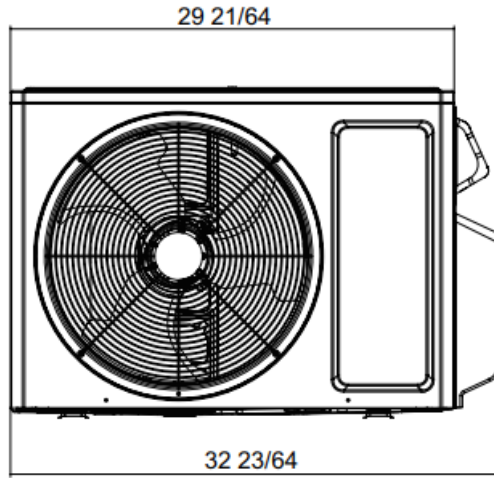

Specification are subject to change without notice.

Job Name:

Schedule Reference:

Date: