



MULTI

9,000 BTUH Multi-zone Ducted

**Model:
KM09HF1DI**

AHRI# 212437225



Include XK76

Item	Unit	Specification
Model	—	KM09HF1DI
System and Electrical Ratings		
Rated Cooling Capacity	Btu/h	9000
Rated Heating Capacity	Btu/h	9500
Sound Pressure (High/Low)	dB(A)	36/25
Air Flow (Min/Max)	CFM	189/324
Ext Static Pressure (Min/Rated/Max)	InWg	0.0 / 0.2 / 0.6
Normal Operational Voltage	—	208-230 V, 1 Ph, 60 Hz
Rated Frequency	Hz	60
Voltage range	V	187-253
MCA/ Power Cable Size	A	1
Unit and Pipe Data		
Interconnecting Cable Wire Size	AWG	AWG14/4
Unit Dimensions (W×D×H)	mm	830x754x300
	Inch	32 43/64 x 29 11/16 x 11 13/16
Weight (Net/Shipping)	lbs	70.6/83.8
Drain Size (OD)	mm	25
	Inch	0 63/64
Refrigerant Type	—	R410A
Gas Pipe Size (OD)	Inch (MM)	3/8 (9,52)
Liquid Pipe Size (OD)	Inch (MM)	1/4 (6)
Connection Method	—	Flared

Job Name:

Schedule Reference:

Date:

Specification are subject to change without notice.

FAN PERFORMANCE

RATED EXTERNAL STATIC PRESSURE	.2 inWc
EXTERNAL STATIC PRESSURE RANGE	0 - .6 inWc

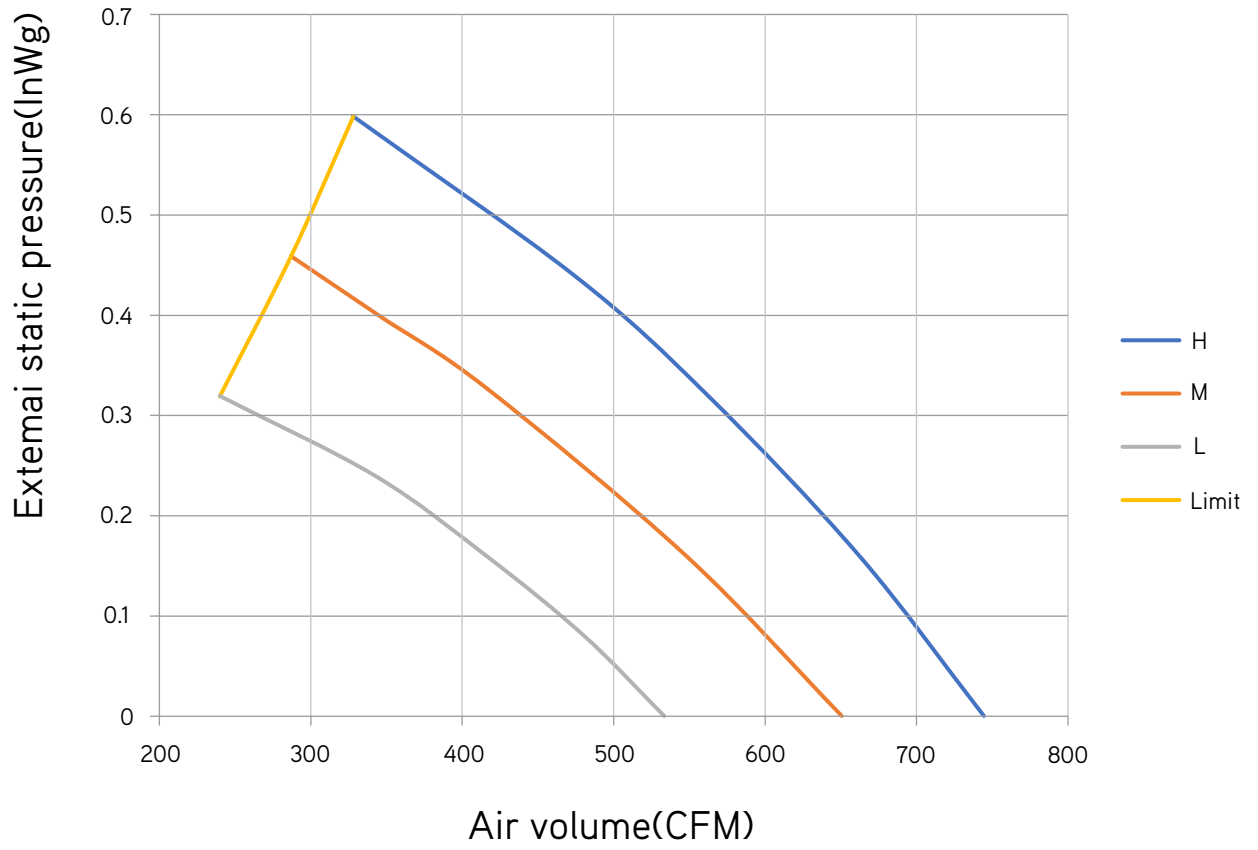

Outline and Physical Dimensions of KM09HF1DI.

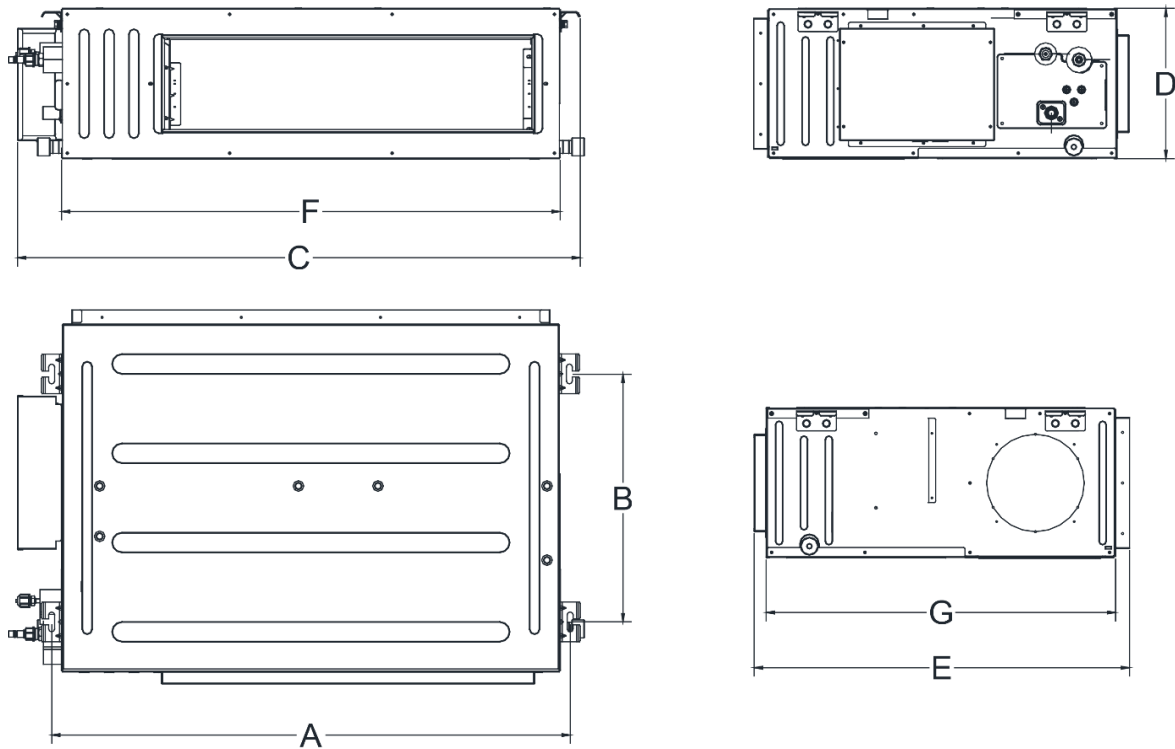

Unit:inch

Model	A	B	C	D	E	F	G
09/12K	29 1/8	19 11/16	32 11/16	11 13/16	29 11/16	27 9/16	27 9/16
18/21/24K	40 15/16	19 11/16	44 1/2	11 13/16	29 11/16	39 3/8	27 9/16

Outdoor Unit

Indoor Unit

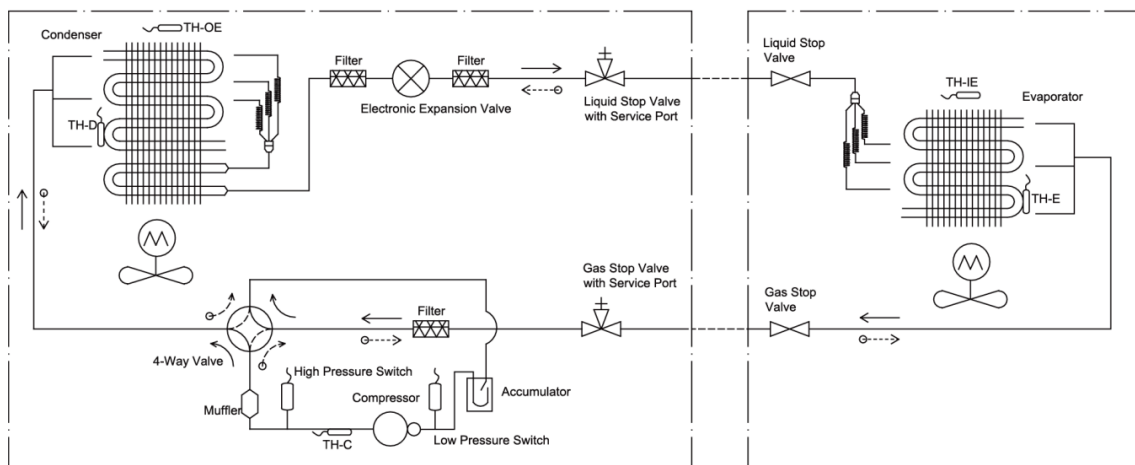

TH-OE: Outdoor Environment Thermal Bulb
 TH-C: Outdoor Condenser Thermal Bulb
 TH-D: Compressor Discharge Thermal Bulb

← Cooling
 ○---> Heating

TH-IE: Indoor Environment Thermal Bulb
 TH-E: Indoor Evaporator Thermal Bulb

Note:
 1. it is just a schematic diagram and some parts may differ from the real objects inside the unit.





**Model:
KW09HQ25SDO**



Outdoor Unit Data

Compressor Type	-	DC Inverter Rotary
Compressor RLA	A	6.5
Refrigerant Type	-	R410A
Fan Motor Power Output	W	30
Fan Motor FLA	A	0.40
Sound Pressure Level	dB(A)	52
Power Supply	-	230V / 1Ph / 60Hz
Min/Max Voltage	V	208~230
Main Supply Wire Size	-	16AWG
MCA	A	10.0
MOCP/Breaker Size	A	15.0

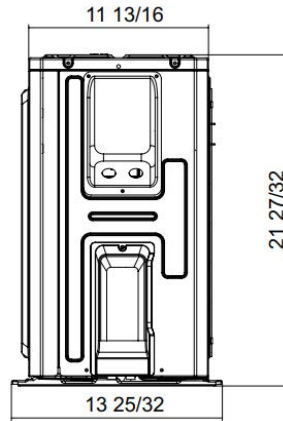
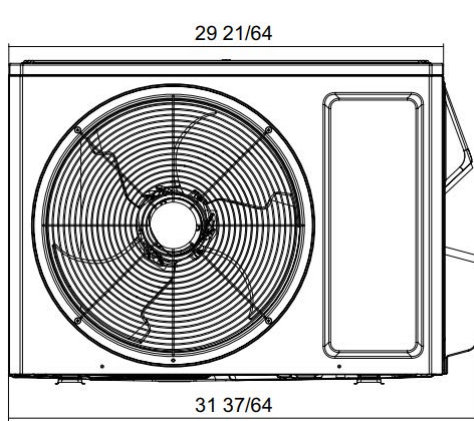

Dimensions	
W	31 37/64 (802)
H	21 27/32 (555)
D	13 25/32 (350)

Units: inch (MM)

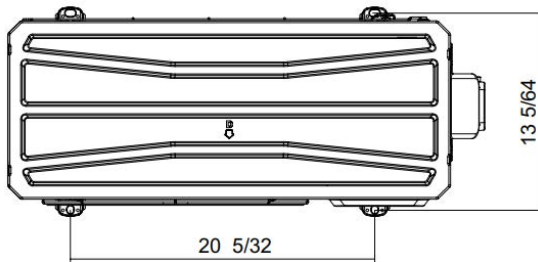

Liquid Line Valve	1/4-in OD Flared
Gas Line Valve	3/8-in OD Flared

Net Weight IDU	20.9 lb (10 kg)
Gross Weight IDU	25.4 lb (12kg)
Net Weight ODU	70.6 lb (32kg)
Gross Weight ODU	76.1 lb (34,5kg)

