



**MULTI**

**24,000 BTUH 8 Way Cassette**

**Model:  
KM24HCKDI**



Optional XK76



Item	Unit	Parameter
Indoor Model	\	KM24HCKDI
<b>Indoor Unit Data</b>		
Cooling Capacity	Btu/h	22800
Heating Capacity	Btu/h	27400
Rated Voltage	V	208-230V/1Ph/60Hz
Recommended Power Cable	\	(4) 16 AWG
Min/Max Voltage	V	187/253
Air Flow Volume (TURBO)	CFM	647
Air Flow Volume (H)	CFM	618
Air Flow Volume (MH)	CFM	559
Air Flow Volume (M)	CFM	536
Air Flow Volume (ML)	CFM	512
Air Flow Volume (L)	CFM	488
Air Flow Volume (SLEEP)	CFM	471
Dehumidifying Volume	Pint/h	5.2
Sound Pressure Level	dB (A)	44/42/41/40/39/38/37
Liquid Pipe	inch	1/4
Gas Pipe	inch	5/8
Connection Method	\	Screw Connection
Drain Connection	inch	0.98
Standard Remote	\	YAP1F7F
Refrigerant Type	\	R410A
Dimension (HxWxD)	inch (mm)	9 29/64 x 33 5/64 x 33 5/64 (240x840x840)
Net Weight	lb (Kg)	63.9 (29)
Gross Weight	lb (Kg)	81.6 (37)
Grille included	\	TF06
Grille Dimension (HxWxD)	inch (mm)	2 3/64 x 37 13/32 x 37 13/32 (52x950x950)

**Job Name:**

**Schedule Reference:**

**Date:**

Specification are subject to change without notice.

# Outline and Physical Dimensions of KM24HCKDI.

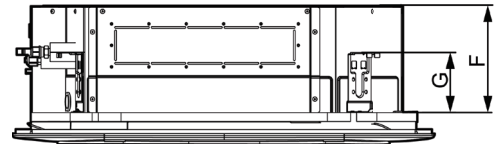
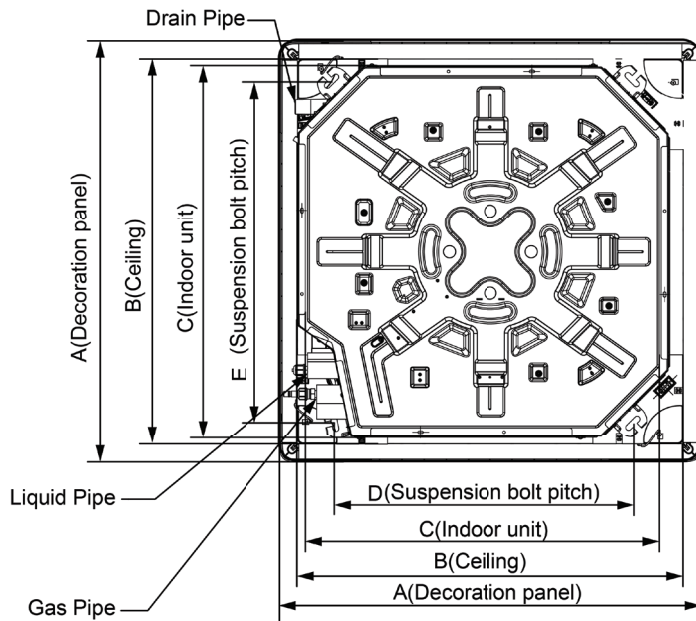

Unit: inch

Model	A	B	C	D	E	F	G
24K	37 13/32	34 1/4	33 5/64	26 49/64	30 45/64	9 29/64	5 5/16

## Outdoor Unit

## Indoor Unit

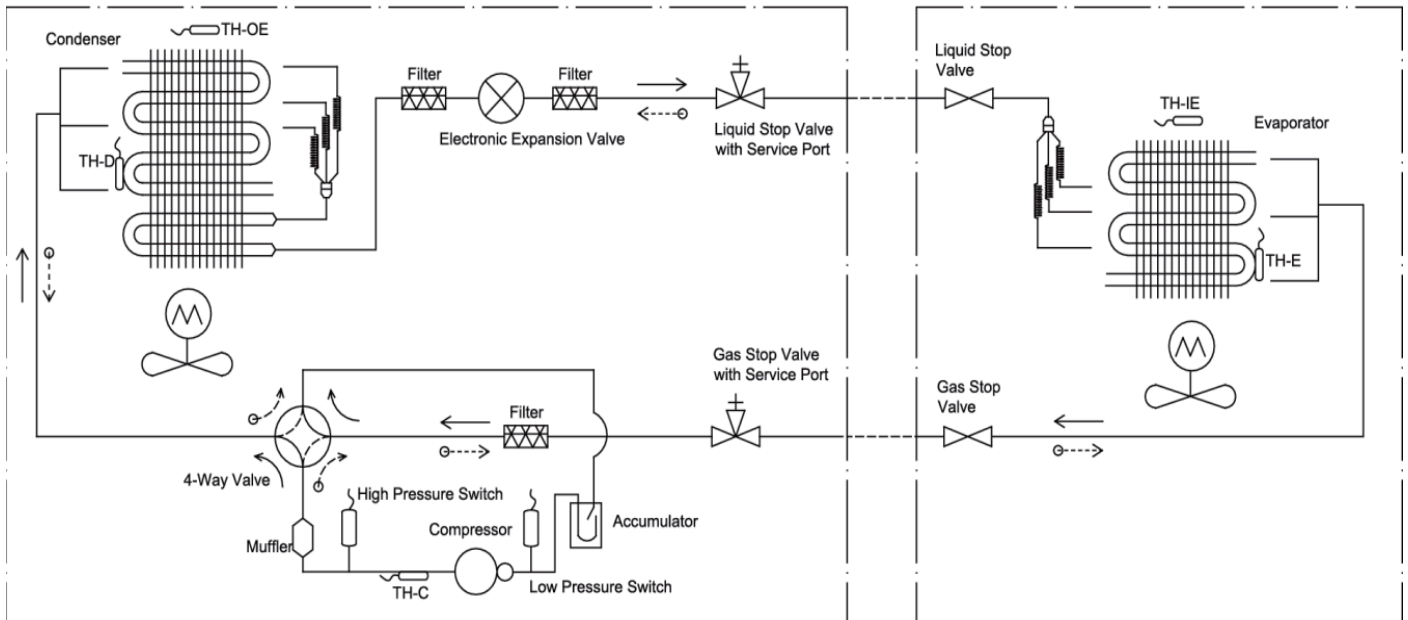

TH-OE: Outdoor Environment Thermal Bulb  
 TH-C: Outdoor Condenser Thermal Bulb  
 TH-D: Compressor Discharge Thermal Bulb

← Cooling  
 ⦿---> Heating

TH-IE: Indoor Environment Thermal Bulb  
 TH-E: Indoor Evaporator Thermal Bulb





**Model:  
KW24HQ25SDO**



**Outdoor Unit Data**

Compressor Type	-	DC Inverter Rotary
Compressor RLA	A	11.0
Refrigerant Type	-	R410A
Fan Motor Power Output	W	90
Fan Motor FLA	A	0.60
Sound Pressure Level	dB(A)	62
Power Supply	-	230V / 1Ph / 60Hz
Min/Max Voltage	V	187~253
Main Supply Wire Size	-	14AWG
MCA	A	16.0
MOCP/Breaker Size	A	25.0

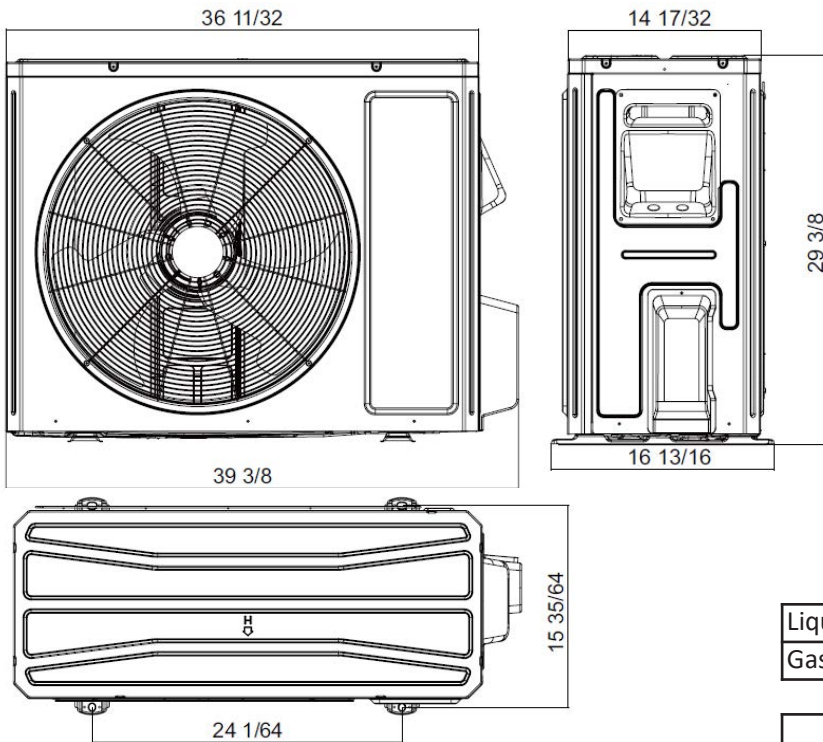

Dimensions	
W	39 3/8 (1000)
H	29 3/8 (746)
D	16 13/16 (427)

Units: inch (MM)

Liquid Line Valve	1/4-in OD Flared
Gas Line Valve	5/8-in OD Flared

Net Weight IDU	35.3 lb (16kg)
Gross Weight IDU	41.9 lb (19kg)
Net Weight ODU	125.7 lb (49kg)
Gross Weight ODU	136.7 lb (54kg)

