



MULTI

18,000 BTUH 8 Way Cassette

**Model:
KM18HCKDI**



Optional XK76



Item	Unit	Parameter
Indoor Model	\	KM18HCKDI
Indoor Unit Data		
Cooling Capacity	Btu/h	14400
Heating Capacity	Btu/h	16000
Rated Voltage	V	208-230V/1Ph/60Hz
Recommended Power Cable	\	(4) 16 AWG
Min/Max Voltage	V	187/253
Air Flow Volume (TURBO)	CFM	383
Air Flow Volume (H)	CFM	318
Air Flow Volume (MH)	CFM	288
Air Flow Volume (M)	CFM	265
Air Flow Volume (ML)	CFM	247
Air Flow Volume (L)	CFM	224
Air Flow Volume (SLEEP)	CFM	206
Dehumidifying Volume	Pint/h	3.8
Sound Pressure Level	dB (A)	43/38/35/34/32/30/29
Liquid Pipe	inch	1/4
Gas Pipe	inch	1/2
Connection Method	\	Screw Connection
Drain Connection	inch	0.98
Standard Remote	\	YAP1F7F
Refrigerant Type	\	R410A
Dimension (HxWxD)	inch (mm)	10 7/16 x 22 7/16 x 22 7/16 (265x570x570)
Net Weight	lb (Kg)	37.4 (17)
Gross Weight	lb (Kg)	48.5 (22)
Grille included	\	TF05
Grille Dimension (HxWxD)	inch (mm)	1 7/8 x 24 13/32 x 24 13/32 (47x620x620)

Job Name:

Schedule Reference:

Date:

Specification are subject to change without notice.

Outline and Physical Dimensions of KM18HCKDI.

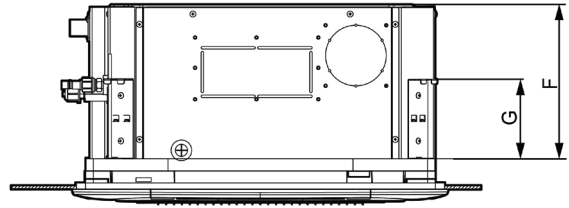
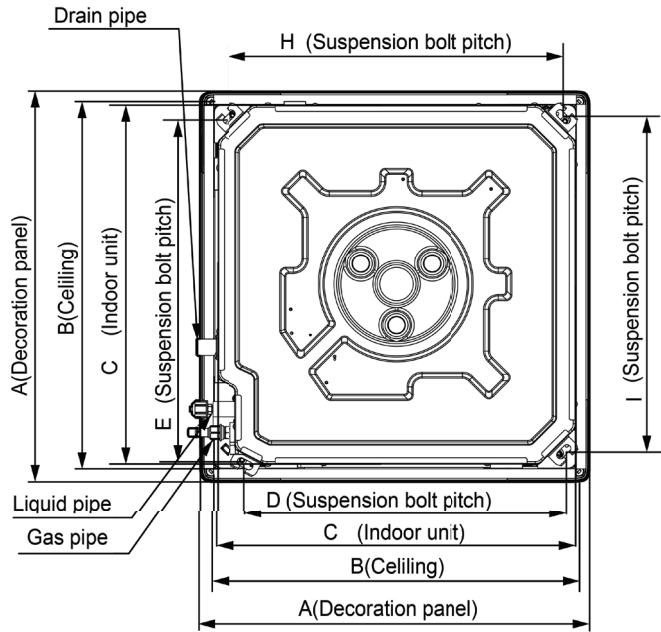

Unit: inch

Model	A	B	C	D	E	F	G	H	I
12/18K	24 13/32	22 53/64	22 7/16	19 7/8	21 21/32	10 7/16	5 33/64	20 55/64	20 55/64

Outdoor Unit

Indoor Unit

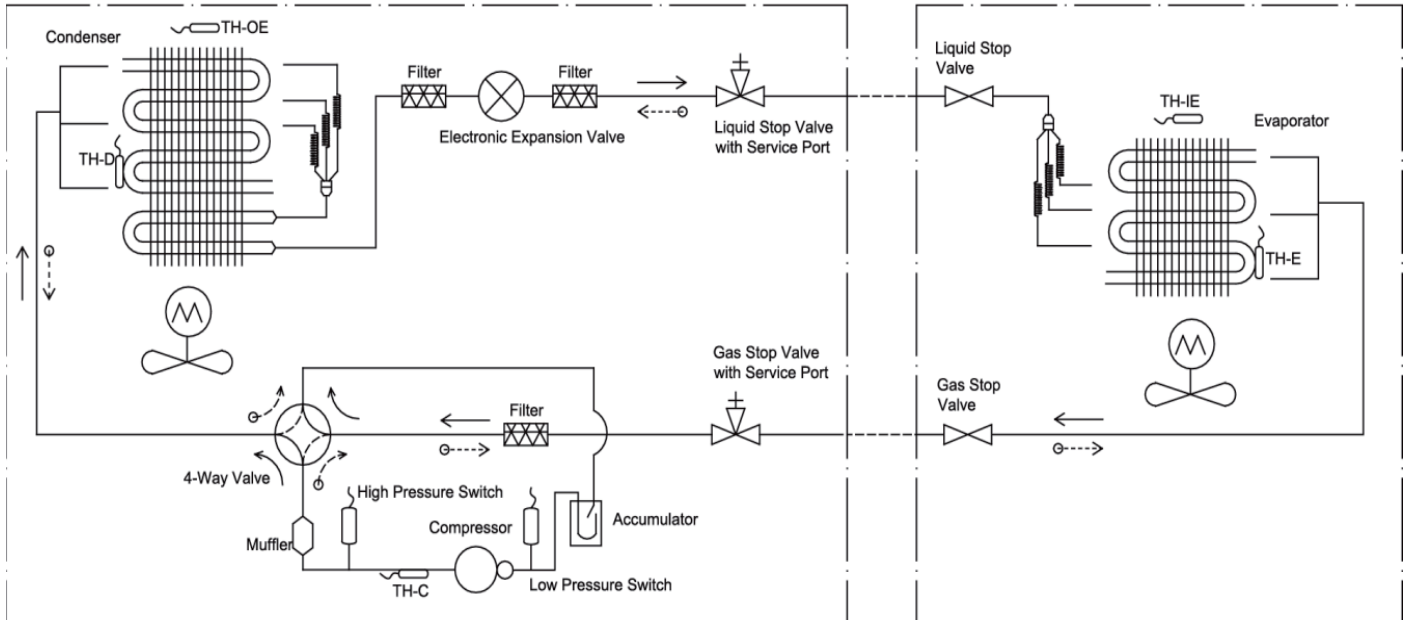

TH-OE: Outdoor Environment Thermal Bulb
 TH-C: Outdoor Condenser Thermal Bulb
 TH-D: Compressor Discharge Thermal Bulb

← Cooling
 ⦿→ Heating

TH-IE: Indoor Environment Thermal Bulb
 TH-E: Indoor Evaporator Thermal Bulb





**Model:
KW18HQ25SDO**



Outdoor Unit Data

Compressor Type	-	DC Inverter Rotary
Compressor RLA	A	9.6
Refrigerant Type	-	R410A
Fan Motor Power Output	W	60
Fan Motor FLA	A	1.35
Sound Pressure Level	dB(A)	58
Power Supply	-	230V / 1Ph / 60Hz
Min/Max Voltage	V	187~253
Main Supply Wire Size	-	14AWG
MCA	A	15.0
MOCP/Breaker Size	A	20.0

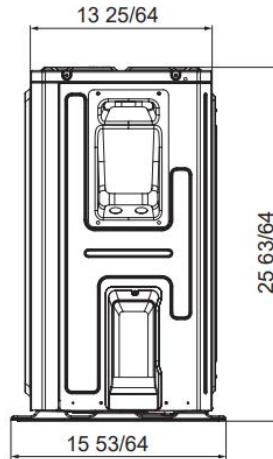
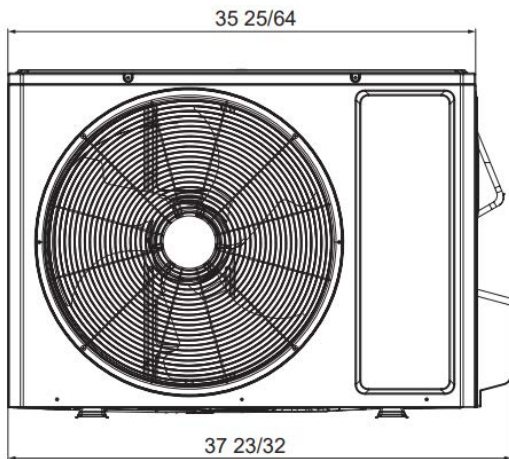

Dimensions	
W	37 23/32 (958)
H	25 63/64 (660)
D	15 53/64 (402)

Units: inch (MM)

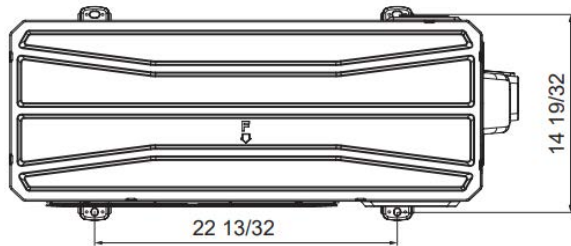

Liquid Line Valve	1/4-in OD Flared
Gas Line Valve	5/8-in OD Flared

Net Weight IDU	28.7 lb (13,5KG)
Gross Weight IDU	35.3 lb (16KG)
Net Weight ODU	95.9 lb (43,5KG)
Gross Weight ODU	105.8 lb (48KG)

