



SPLIT TYPE

PULAR

Model:
KW24HQ25SDI
KW24HQ25SDO

#AHRI : 209847251



Item	Unit	Specification
ODU Model	-	KW24HQ25SDO
IDU Model	-	KW24HQ25SDI
System Ratings		
Cooling Capacity	Btu/h	22000
Heating Capacity (47°F)	Btu/h	24000
Heating Capacity (17°F)	Btu/h	15000
Cooling Capacity Range	Btu/h	8870~28000
Heating Capacity Range	Btu/h	7200~30708
Cooling Power Input (Max)	W	2600
Heating Power Input (Max)	W	3100
SEER2	-	24.5
HSPF2	-	9.5
EER	W/W	3.85
COP	W/W	3.76
Cooling Operation Range	°F (°C)	-20~122(-29~50)
Heating Operation Range	°F (°C)	-22~86(-30~30)
Gas Pipe Size (OD)	Inch (MM)	5/8 (16)
Liquid Pipe Size (OD)	Inch(MM)	1/4 (6)
Connection Method	-	Flared
Factory Charge	oz	60.0
Additional Charge	oz/ft	0.5
Pre-Charge Length	ft.	25
MAX Refrigerant Length	ft.	131
Min Refrigerant Pipe Length	ft.	10
MAX Refrigerant Pipe Elevation	ft.	82
Indoor Unit Data		
Fan Motor Power Output	W	60
Fan Motor FLA	A	0.4
Air Flow Volume	CFM	383/736
Sound Pressure Level	dB(A)	34/52
Dehumidification	pt/hr	5.07
Power Supply	-	230V / 1Ph / 60Hz
Min/Max Voltage	V	187~253
MCA	A	-
MOCP/Breaker Size	A	-
Outdoor Unit Data		
Compressor Type	-	DC Inverter Rotary
Compressor RLA	A	11.0
Refrigerant Type	-	R410A
Fan Motor Power Output	W	90
Fan Motor FLA	A	0.60
Sound Pressure Level	dB(A)	62
Power Supply	-	230V / 1Ph / 60Hz
Min/Max Voltage	V	187~253
Main Supply Wire Size	-	14AWG
MCA	A	16.0
MOCP/Breaker Size	A	25.0

Job Name:

Schedule Reference:

Date:

Specification are subject to change without notice.



Outline and Physical Dimension of KW24HQ25SD

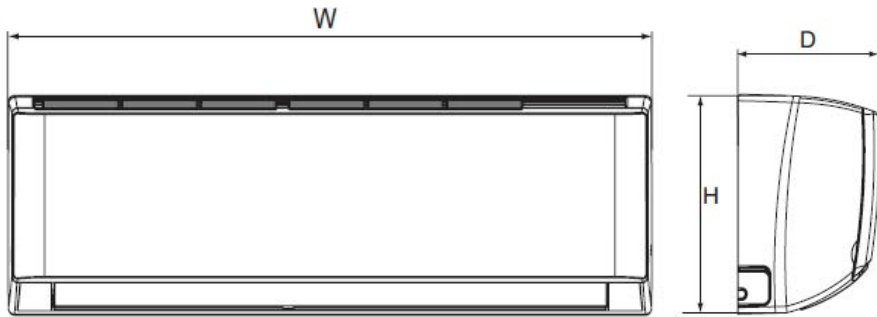

Dimensions	
W	42 3/8 (1078)
H	12 51/64 (325)
D	9 3/4 (246)

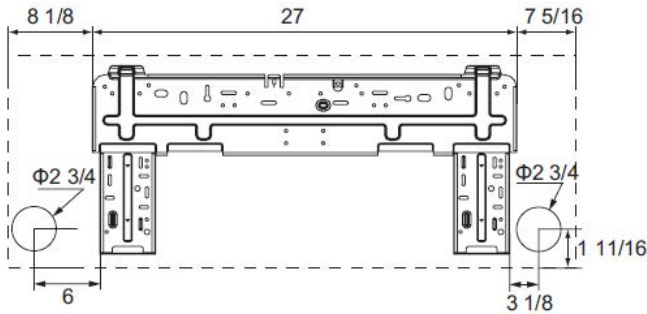

Liquid Line Valve	1/4-in OD Flared
Gas Line Valve	5/8-in OD Flared
Drain Connector	5/8-in OD

Units: inch (MM)

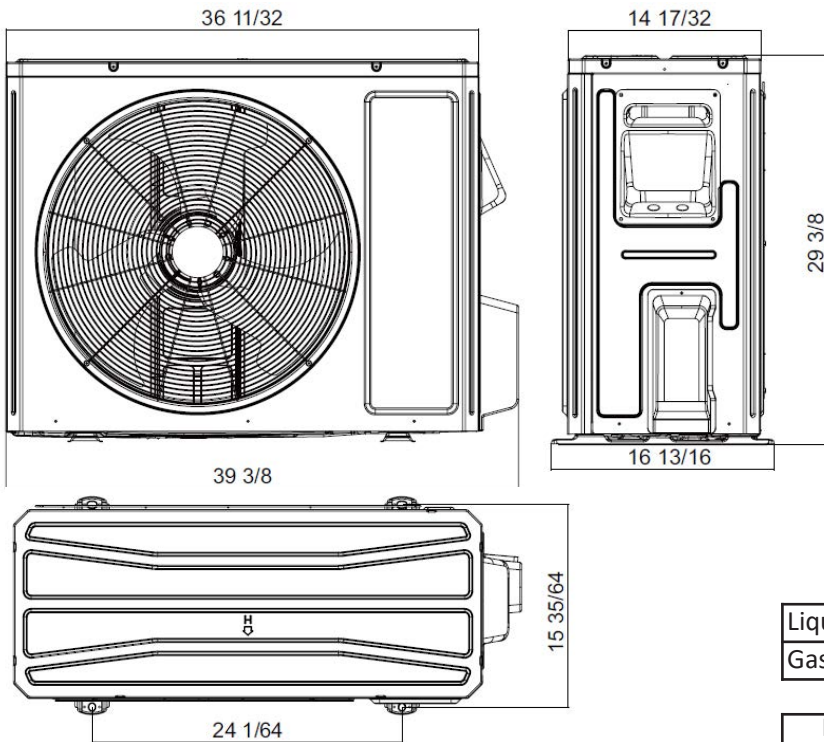

Dimensions	
W	39 3/8 (1000)
H	29 3/8 (746)
D	16 13/16 (427)

Units: inch (MM)

Liquid Line Valve	1/4-in OD Flared
Gas Line Valve	5/8-in OD Flared

Net Weight IDU	35.3 lb (16kg)
Gross Weight IDU	41.9 lb (19kg)
Net Weight ODU	125.7 lb (49kg)
Gross Weight ODU	136.7 lb (54kg)

