



SPLIT TYPE

PULAR

**Model:
KW12HQ25SDI
KW12HQ25SDO**

#AHRI : 209847247



Item	Unit	Specification
ODU Model	-	KW12HQ25SDO
IDU Model	-	KW12HQ25SDI
System Ratings		
Cooling Capacity	Btu/h	12000
Heating Capacity (47°F)	Btu/h	12000
Heating Capacity (17°F)	Btu/h	7000
Cooling Capacity Range	Btu/h	3070~14098
Heating Capacity Range	Btu/h	3070~15500
Cooling Power Input (Max)	W	1400
Heating Power Input (Max)	W	1500
SEER2	-	24.0
HSPF2	-	9.0
EER	W/W	3.66
COP	W/W	3.81
Cooling Operation Range	°F (°C)	-20~122(-29~50)
Heating Operation Range	°F (°C)	-22~86(-30~30)
Gas Pipe Size (OD)	Inch(MM)	1/2 (12)
Liquid Pipe Size (OD)	Inch(MM)	1/4 (6)
Connection Method	-	Flared
Factory Charge	oz	42.3
Additional Charge	oz/ft	0.215
Pre-Charge Length	ft.	24.6
MAX Refrigerant Length	ft.	65
Min Refrigerant Pipe Length	ft.	10
MAX Refrigerant Pipe Elevation	ft.	40
Indoor Unit Data		
Fan Motor Power Output	W	20
Fan Motor FLA	A	0.2
Air Flow Volume	CFM	230/400
Sound Pressure Level	dB(A)	27/44
Dehumidification	pt/hr	2.96
Power Supply	-	230V / 1Ph / 60Hz
Min/Max Voltage	V	187~253
MCA	A	-
MOCP/Breaker Size	A	-
Outdoor Unit Data		
Compressor Type	-	DC Inverter Rotary
Compressor RLA	A	6.8
Refrigerant Type	-	R410A
Fan Motor Power Output	W	30
Fan Motor FLA	A	0.40
Sound Pressure Level	dB(A)	52
Power Supply	-	230V / 1Ph / 60Hz
Min/Max Voltage	V	187~253
Main Supply Wire Size	-	16AWG
MCA	A	10.0
MOCP/Breaker Size	A	15.0

Job Name:

Schedule Reference:

Date:

Specification are subject to change without notice.



Outline and Physical Dimension of KW12HQ25SD

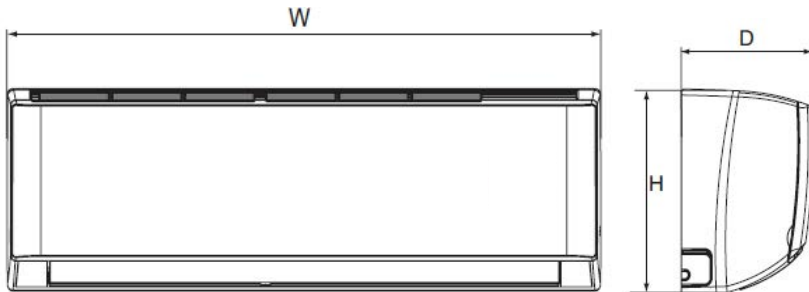

Dimensions	
W	33 17/64 (845)
H	11 3/8 (288)
D	8 15/64 (209)

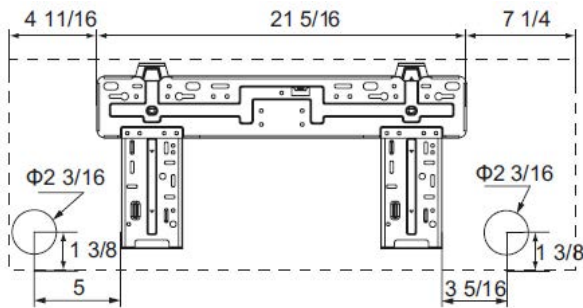

Liquid Line Valve	1/4-in OD Flared
Gas Line Valve	1/2-in OD Flared
Drain Connector	5/8-in OD

Units: inch (MM)

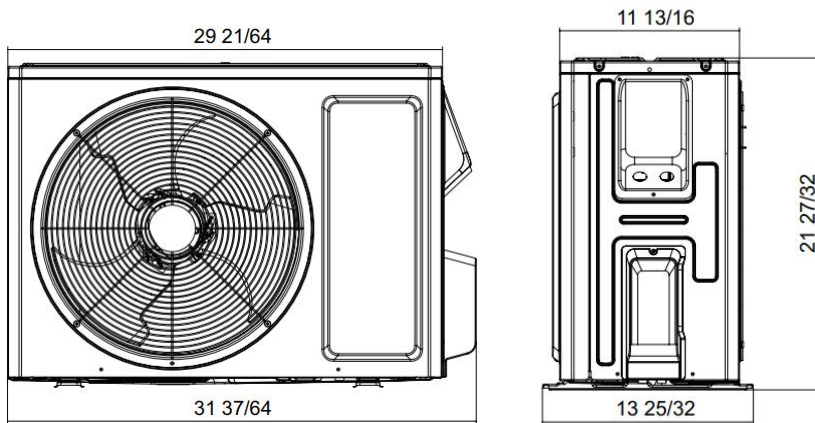

Dimensions	
W	31 37/64 (802)
H	21 27/32 (555)
D	13 25/32 (350)

Units: inch (MM)

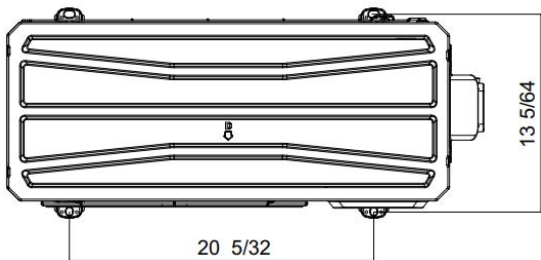

Liquid Line Valve	1/4-in OD Flared
Gas Line Valve	1/2-in OD Flared

Net Weight IDU	22.5 lb (10kg)
Gross Weight IDU	26.4 lb (22kg)
Net Weight ODU	70.6 lb (32kg)
Gross Weight ODU	76.1 lb (34,5kg)

