



SPLIT TYPE

CHARMO

**Model:
KW36HQ20SDI
KW36HQ20SDO**

#AHRI : 211177527



Item	Unit	Specification
ODU Model	-	KW36HQ20SDO
IDU Model	-	KW36HQ20SDI
System Ratings		
Cooling Capacity	Btu/h	33600
Heating Capacity (47°F)	Btu/h	34600
Heating Capacity (17°F)	Btu/h	22000
Cooling Capacity Range	Btu/h	7500~37200
Heating Capacity Range	Btu/h	10200~38500
Cooling Power Input (Max)	W	3200
Heating Power Input (Max)	W	3200
SEER2	-	20
HSPF2	-	8.5
EER	W/W	3.08
COP	W/W	3.17
Cooling Operation Range	°F (°C)	-4~122(-20~50)
Heating Operation Range	°F (°C)	-13~75(-25~24)
Gas Pipe Size (OD)	Inch (MM)	5/8 (16)
Liquid Pipe Size (OD)	Inch(MM)	1/4 (6)
Connection Method	-	Flared
Factory Charge	oz	84.7
Additional Charge	oz/ft	0.5
Pre-Charge Length	ft.	25
MAX Refrigerant Length	ft.	82
Min Refrigerant Pipe Length	ft.	10
MAX Refrigerant Pipe Elevation	ft.	33
Indoor Unit Data		
Fan Motor Power Output	W	70
Fan Motor FLA	A	0.75
Air Flow Volume	CFM	471/912
Sound Pressure Level	dB(A)	37/56
Dehumidication	pt/hr	7.4
Power Supply	-	230V / 1Ph / 60Hz
Min/Max Voltage	V	187~253
MCA	A	-
MOCP/Breaker Size	A	-
Outdoor Unit Data		
Compressor Type	-	DC Inverter Rotary
Compressor RLA	A	16
Refrigerant Type	-	R410A
Fan Motor Power Output	W	90
Fan Motor FLA	A	1.5
Sound Pressure Level	dB(A)	62
Power Supply	-	230V / 1Ph / 60Hz
Min/Max Voltage	V	187~253
Main Supply Wire Size	-	12AWG
MCA	A	23
MOCP/Breaker Size	A	35

Job Name:

Schedule Reference:

Date:

Specification are subject to change without notice.



Outline and Physical Dimension of KW36HQ20SD

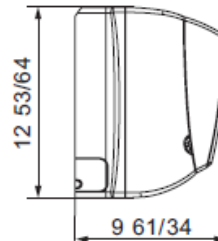
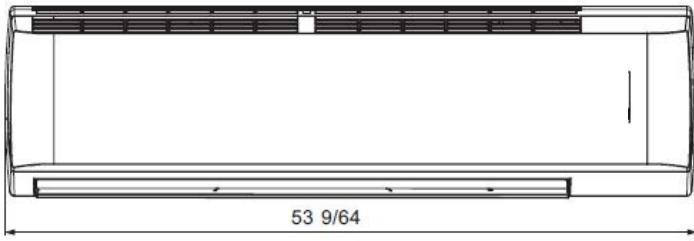

Dimensions	
W	53 9/64 (1350)
H	12 53/64 (326)
D	9 61/64 (253)

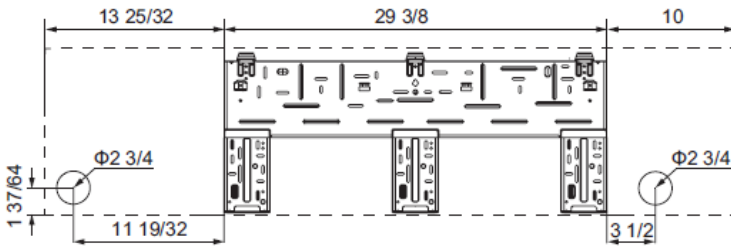

Liquid Line Valve	1/4-in OD Flared
Gas Line Valve	5/8-in OD Flared
Drain Connector	5/8-in OD

Units: inch (MM)

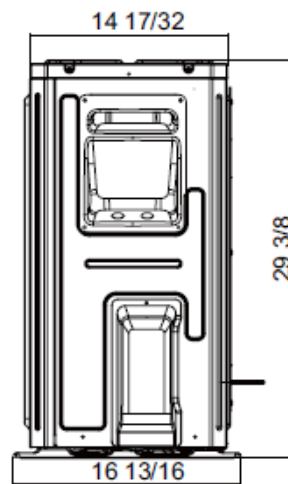
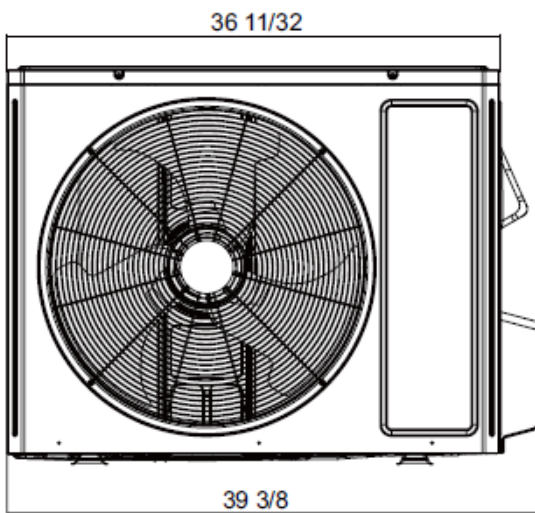

Dimensions	
W	39 3/8 (1000)
H	29 3/8 (746)
D	16 13/16 (427)

Units: inch (MM)

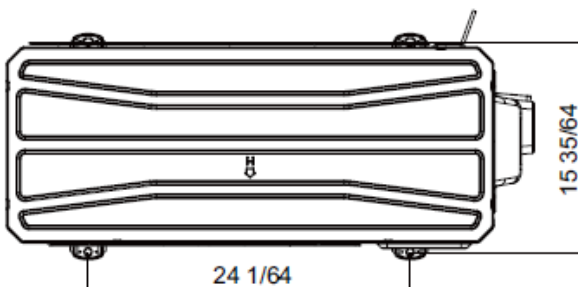

Liquid Line Valve	1/4-in OD Flared
Gas Line Valve	5/8-in OD Flared

Net Weight IDU	44.1 lb (20kg)
Gross Weight IDU	54 lb (24,5kg)
Net Weight ODU	127.9 lb (58kg)
Gross Weight ODU	138.9 lb (63kg)





DIMENSIONAL SPECIFICATIONS

KW36HQ20SD

MINIMUM SPACING REQUIREMENTS

Units: inch

INDOOR

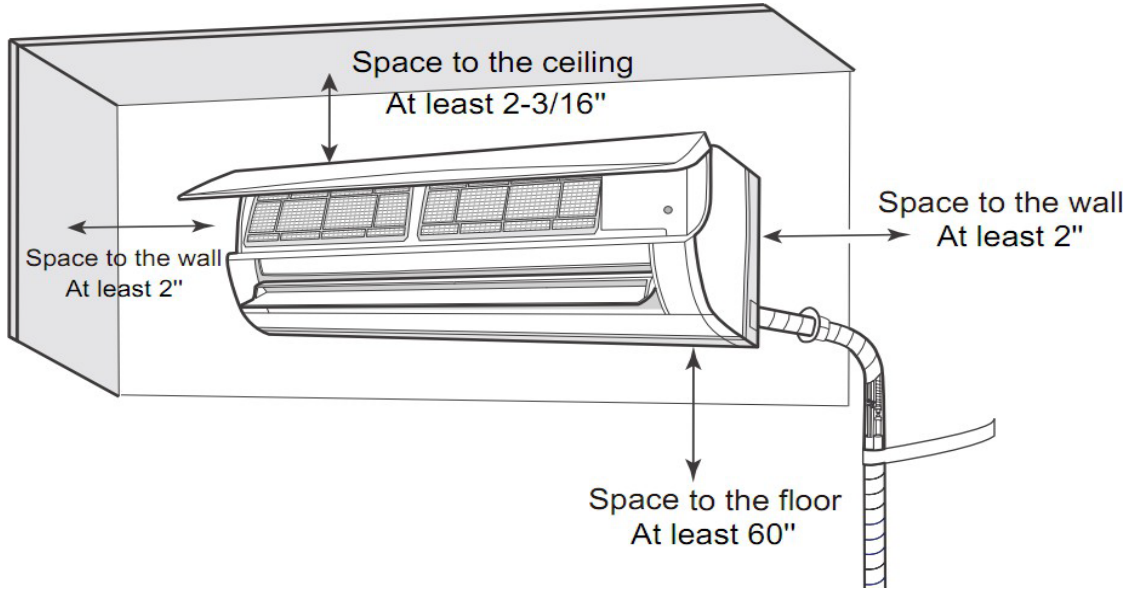

Units: inch (mm)

OUTDOOR

