



SPLIT TYPE

CHARMO

Model:
KW18HQ19SDI
KW18HQ19SDO

#AHRI : 212396484

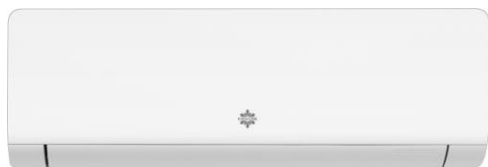

Item	Unit	Specification
ODU Model	-	KW18HQ19SDO
IDU Model	-	KW18HQ19SDI
System Ratings		
Cooling Capacity	Btu/h	17600
Heating Capacity (47°F)	Btu/h	19100
Heating Capacity (17°F)	Btu/h	11200
Cooling Capacity Range	Btu/h	3753-19960
Heating Capacity Range	Btu/h	2730-22519
Cooling Power Input (Max)	W	1750
Heating Power Input (Max)	W	2300
SEER2	-	17.5
HSPF2	-	8.0
EER	W/W	2.95
COP	W/W	3.2
Cooling Operation Range	°F (°C)	0~118(-18~48)
Heating Operation Range	°F (°C)	-13~75(-25~24)
Gas Pipe Size (OD)	Inch(MM)	1/2 (12)
Liquid Pipe Size (OD)	Inch(MM)	1/4 (6)
Connection Method	-	Flared
Factory Charge	oz	44.1
Additional Charge	oz/ft	0.2
Pre-Charge Length	ft.	25
MAX Refrigerant Length	ft.	82
Min Refrigerant Pipe Length	ft.	10
MAX Refrigerant Pipe Elevation	ft.	33
Indoor Unit Data		
Fan Motor Power Output	W	45
Fan Motor FLA	A	0.7
Air Flow Volume	CFM	283/618
Sound Pressure Level	dB(A)	32/51
Dehumidication	pt/hr	3.8
Power Supply	-	208-230V / 1Ph / 60Hz
Min/Max Voltage	V	187 - 253
MCA	A	-
MOCP/Breaker Size	A	-
Outdoor Unit Data		
Compressor Type	-	DC Inverter Rotary
Compressor RLA	A	9.4
Refrigerant Type	-	R410A
Fan Motor Power Output	W	30
Fan Motor FLA	A	0.9
Sound Pressure Level	dB(A)	57
Power Supply	-	208-230V / 1Ph / 60Hz
Min/Max Voltage	V	187 - 253
Main Supply Wire Size	-	14AWG
MCA	A	14.0
MOCP/Breaker Size	A	20.0



Job Name:

Schedule Reference:

Date:

Specification are subject to change without notice.



Outline and Physical Dimension of KW18HQ19SD

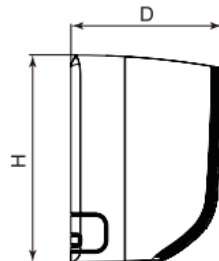
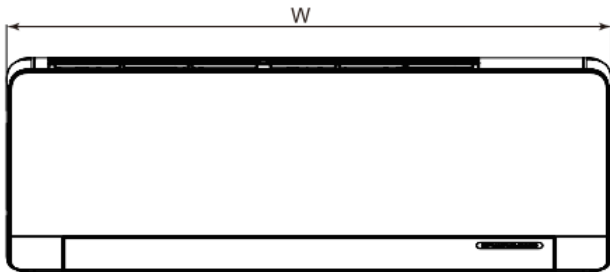

Dimensions	
W	38 1/2 (978)
H	13 7/64 (333)
D	9 49/64 (248)

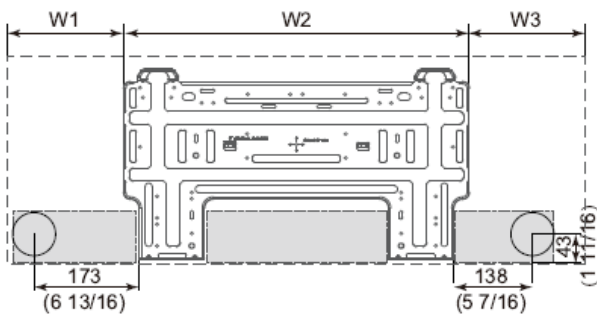

Liquid Line Valve	1/4-in OD Flared
Gas Line Valve	1/2-in OD Flared
Drain Connector	5/8-in OD

Units: inch (MM)

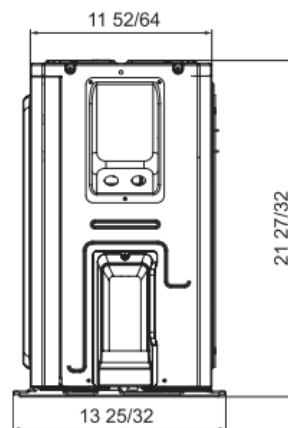
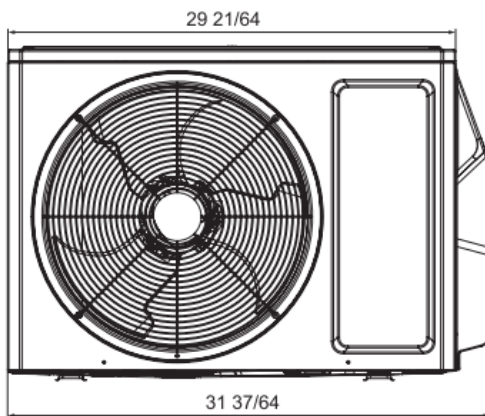

Dimensions	
W	31 37/64 (802)
H	21 27/32 (555)
D	13 5/64 (350)

Units: inch (MM)

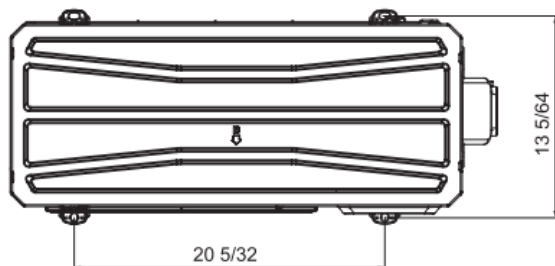

Liquid Line Valve	1/4-in OD Flared
Gas Line Valve	1/2-in OD Flared

Net Weight IDU	29.8 lb (13,5 kg)
Gross Weight IDU	35.3 lb (16 kg)
Net Weight ODU	71.7 lb (32,5 kg)
Gross Weight ODU	77.2 lb (35 kg)

