



Owner's Manual

Original Instructions

Kinghome Rooftop Packaged Air Conditioner

Models:

KRH05TCU

KRH04TCU

KRH03TCU

KRH02TCU

CAPACITY RANGE:

24000~57000Btu/h(7.04~16.7kW)

OPERATION RANGE:

COOLING: 23°F(-5°C)~125.6°F(52°C)

HEATING: -22°F(-30°C)~75.2°F(24°C)



To Users

Thank you for selecting Kinghome product. Please read this instruction manual carefully before installing and using the product, so as to master and correctly use the product. In order to guide you to correctly install and use our product and achieve expected operating effect, we hereby instruct as below:

- (1) This appliance is not intended for use by persons (including children) with reduced physical, sensory or mental capabilities, or lack of experience and knowledge, unless they have been given supervision or instruction concerning use of the appliance by a person responsible for their safety. Children should be supervised to ensure that they do not play with the appliance.
- (2) In order to ensure reliability of product, the product may consume some power under stand-by status for maintaining normal communication of system and preheating refrigerant and lubricant. If the product is not to be used for long, cut off the power supply; please energize and preheat the unit in advance before reusing it.
- (3) Please properly select the model according to actual using environment, otherwise it may impact the using convenience.
- (4) This product can't be installed at corrosive, inflammable or explosive environment or the place with special requirements, such as kitchen. Otherwise, it will affect the normal operation or shorten the service life of the unit, or even cause fire hazard or serious injury. As for above special places, please adopt special air conditioner with anti-corrosive or anti-explosion function.
- (5) If the product needs to be installed, moved or maintained, please contact our designated dealer or local service center for professional support. Users should not disassemble or maintain the unit by themselves, otherwise it may cause relative damage, and our company will bear no responsibilities.
- (6) All the illustrations and information in the instruction manual are only for reference. In order to make the product better, we will continuously conduct improvement and innovation. If there is adjustment in the product, please subject to actual product.

Exception Clauses

Manufacturer will bear no responsibilities when personal injury or property loss is caused by the following reasons:

- (1) Damage the product due to improper use or misuse of the product.
- (2) Alter, change, maintain or use the product with other equipment without abiding by the instruction manual of manufacturer.
- (3) After verification, the defect of product is directly caused by corrosive gas.
- (4) After verification, defects are due to improper operation during transportation of product.
- (5) Operate, repair, maintain the unit without abiding by instruction manual or related regulations.
- (6) After verification, the problem or dispute is caused by the quality specification or performance of parts and components that produced by other manufacturers.
- (7) The damage is caused by natural calamities, bad using environment or force majeure.

Contents

1 Safety Precautions	1
2 Product Introduction	4
2.1 Product Description	4
2.2 Operating Range	4
2.3 Standard Accessory Parts	5
3 Installation	5
3.1 Installation Preparation	5
3.2 Unit Installation	10
3.3 Ductwork	16
3.4 Electric Heater	17
3.5 Electrical Installation	19
3.6 Wiring Diagram	22
3.7 Engineering Wiring Diagram	24
3.8 Check after Installation	24
3.9 Test Running	25
4 Troubleshooting	26
5 Code List	26
6 Maintenance	29
6.1 Cleaning the Air Filter	29
6.2 Drainage Pipe	29
6.3 Cleaning the Heat Exchanger	29
6.4 Notice before Seasonal Use	30
6.5 Maintenance after Seasonal Use	30
6.6 Parts Replacement	30
7 After-sales Service	30

This marking indicates that this product should not be disposed with other household wastes throughout the North America. To prevent possible harm to the environment or human health from uncontrolled waste disposal, recycle it responsibly to promote the sustainable reuse of material resources. To return your used device, please use the return and collection systems or contact the retailer where the product was purchased. They can take this product for environmental safe recycling.



1 Safety Precautions

WARNING

This product can't be installed at corrosive, inflammable or explosive environment or the place with special requirements, such as kitchen. Otherwise, it will affect the normal operation or shorten the service life of the unit, or even cause fire hazard or serious injury. As for above special places, please adopt special air conditioner with anti-corrosive or anti-explosion function.

Improper installation, adjustment, alteration, service, maintenance, or use can cause explosion, fire, electrical shock, or other conditions which may cause death, personal injury, or property damage. Consult a qualified installer, service agency, or your distributor or branch for information or assistance. The qualified installer or agency must use factory--authorized kits or accessories when modifying this product. Refer to the individual instructions packaged with the kits or accessories when installing. Follow all safety codes. Wear safety glasses, protective clothing, and work gloves. Use quenching cloth for brazing operations. Have fire extinguisher available. Read these instructions thoroughly and follow all warnings or cautions included in literature and attached to the unit. Consult local building codes and National Electrical Code (NEC) for special requirements. Recognize safety information. This is the safety--alert symbol .

When you see this symbol on the unit and in instructions or manuals, be alert to the potential for personal injury. Understand these signal words: **DANGER**, **WARNING**, **CAUTION** and **NOTICE**. These words are used with the safety--alert symbol.

DANGER

Indicates a hazardous situation that, if not avoided, will result in death or serious injury.

WARNING

Indicates a hazardous situation that, if not avoided, could result in death or serious injury.

CAUTION

Indicates a hazardous situation that, if not avoided, may result in minor or moderate injury.

NOTICE

Indicates important but not hazard-related information, used to indicate risk of property damage.

Electrical shock hazard:

Failure to follow this warning could result in personal injury or death.

Before installing, modifying, or servicing system, main electrical disconnect switch must be in the OFF position. There may be more than 1 disconnect switch. Lock out and tag switch with a suitable warning label.

 WARNING	
(1)	The air conditioner should be grounded to avoid electric shock. Do not connect the ground wire to gas pipe, water pipe, lightning arrester or telephone wire.
(2)	The appliance shall be stored in a well-ventilated area where the room size corresponds to the room area as specified for operation.
(3)	The appliance shall be stored in a room without continuously operating open flames (for example an operating gas appliance) and ignition sources (for example an operating electric heater).
(4)	According to federal/state/local laws and regulations, all packages and transportation materials, including nails, metal or wooden parts, and plastic packing material, must be treated in a safe way.
(5)	The air conditioner should be at least 1.5m away from any inflammable surface.
(6)	The range of external static pressures(0-0.8 Inches W.C.) at which the appliance was tested(add-on heat pumps and ducted appliances with supplementary heaters only).

 WARNING	
(1)	Please install according to this instruction manual. Installation must be performed in accordance with the requirement of NEC and CEC by authorized personnel only.
(2)	Any person who is involved with working on or breaking into a refrigerant circuit should hold a current valid certificate from an industry-accredited assessment authority, which authorizes their competence to handle refrigerants safely in accordance with an industry recognized assessment specification.
(3)	Servicing shall only be performed as recommended by the equipment manufacturer.
(4)	The appliance shall be installed in accordance with national wiring regulations.
(5)	The fixed wires connecting to the appliance must be configured with all-pole disconnection device under voltage grade III according to wiring rules.
(6)	Air conditioner should be stored with protective measures against mechanical damage caused by accident.
(7)	During installation, use the specialized accessories and components, otherwise water leakage, electric shock or fire hazard may occur.
(8)	Please install the air conditioner in a secure place that can withstand the weight of air conditioner. Insecure installation may cause the air conditioner falling down and lead to injury.

⚠ WARNING

- | | |
|------|---|
| (9) | Be sure to adopt independent power circuit. If the power cord is damaged, it must be repaired by the manufacturer, service agent or other professional agents. |
| (10) | The air conditioner can be cleaned only after it is turned off and power-disconnected, otherwise electric shock may occur. |
| (11) | The air conditioner is not intended to be cleaned or maintained by children without supervision. |
| (12) | Do not alter the setting of pressure sensor or other protective devices. If the protective devices are short-circuited or changed against rules, fire hazard or even explosion may occur. |
| (13) | Do not operate the air conditioner with wet hands. Do not wash or sprinkle water on the air conditioner, otherwise malfunction or electric shock will occur. |
| (14) | Do not dry the filter with naked flame or an air blower; otherwise the filter will be out of shape. |
| (15) | If the unit is to be installed in a small space, please adopt protective measures to prevent the concentration of refrigerant from exceeding the allowable safety limit; excessive refrigerant leakage may lead to explosion. |

NOTICE

- | | |
|-----|--|
| (1) | Do not put a finger or other objects into the air inlet or return air grill. |
| (2) | Please adopt safety protection measures before touching the refrigerant pipe; otherwise your hands may be hurt. |
| (3) | Please arrange the drain pipe according to the instruction manual. |
| (4) | Never stop the air conditioner by directly cutting off the power. |
| (5) | Never install the air conditioner in the following places: <ul style="list-style-type: none"> a) Places with oil smoke or volatile liquid: plastic parts may deteriorate and fall off or even cause water leakage. b) Places with corrosive gas: copper pipe or the welding parts may be corroded and cause refrigerant leakage. |
| (6) | Adopt proper measures to protect the air conditioner from small animals because they may damage the electric components and cause malfunction of the air conditioner. |

NOTICE

- | | |
|-----|--|
| (1) | If thermostat is to be used, it should be connected first before powering up the unit, otherwise the thermostat may not be able to use. |
| (2) | Only use soft dry cloth or slightly wet cloth with neutral detergent to clean the casing of the air conditioner. |
| (3) | Before operating the unit under low temperature, connect it to power for 8 hours. If it is stopped for a short time, for example, one night, do not cut off the power (This is to protect the compressor). |

NOTICE

- (4) In order to ensure the reliability of the compressor, the unit force the compressor run for at least 6 minutes every time the compressor turns on, regardless of the room temperature. Therefore, it is necessary to select a thermostat having the minimum run time for the compressor or delaying a few minutes to turn the indoor unit off after the outdoor unit is shut down or stopped at the temperature point, in order to avoid that the indoor unit is turned off by the thermostat while the out unit is running which can result in the malfunction of the air conditioner.

2 Product Introduction

2.1 Product Description

The unit is completely assembled, piped and wired at the factory to provide one-piece shipment and rigging. Each unit is pressurized with a holding charge of R410A for storage and shipping.

The compact design, attractive appearance, outstanding anti-rust cabinet and quiet operation make these units suitable for homes, offices, restaurants, residences or similar places.

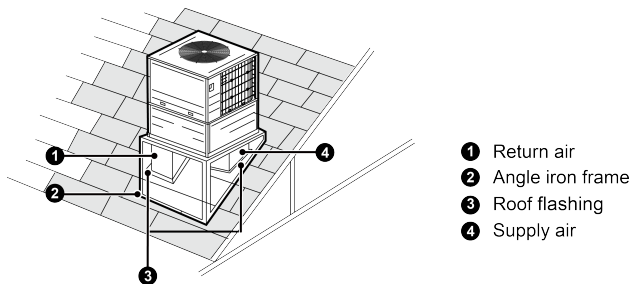



Fig.1

2.2 Operating Range

Mode	Outdoor Condition (DB Temperature)
Cooling	23°F(-5°C) ~ 125°F (52°C)
Heating	-22°F (-30°C) ~ 75.2°F (24°C)

2.3 Standard Accessory Parts

The standard accessory parts listed below are furnished and should be used as required.

No.	Name	Appearance	Q'ty	Usage
1	Wired controller		1	To control the unit

3 Installation

3.1 Installation Preparation

3.1.1 Checking Product Received

After receiving the product, please check if there is any damage caused by transportation. Shipping damage is the responsibility of the carrier. Verify the model number, specifications and accessories are correct prior to installation. The distributor or manufacturer will not accept claims from dealers for transportation damage or installation of incorrectly shipped units.

3.1.2 Before Installation

Carefully read all instructions for the installation prior to installing product. Make sure each step or procedure is understood and any special considerations are taken into account before starting installation. Assemble all tools, hardware and supplies needed to complete the installation. Some items may need to be purchased locally. Make sure everything needed to install the product is on hand before starting.

3.1.3 Codes & Regulations

This product is designed and manufactured to comply with national codes. It is installer's responsibilities to install the product in accordance with such codes and/or any prevailing local codes/regulations. The manufacturer assumes no responsibilities for equipment installed in violation of any codes or regulations.

3.1.4 Replacement Parts

When reporting shortages or damages, or ordering repair parts, give the complete product model and serial numbers as stamped on the product. Replacement parts for this product are available through your contractor or local distributor.

3.1.5 Selection of Installation Location

 WARNING
--

- | | |
|---|---|
| ① | The unit must be installed where strong enough to withstand the weight of the unit and fixed securely, otherwise the unit would topple or fall off. |
| ② | Do not install where there is the danger of combustible gas leakage. |
| ③ | Do not install the unit at a place with leakage of inflammable gas. |

Selection of installation location (Select a location pursuant to the following condition).

- (1) Noise and air flow produced by the air conditioner will not disturb the neighbors.
- (2) Select a location that is safe and away from animals and plants. If not, please add safety fences to protect the unit.
- (3) Install at a place with good ventilation. Make sure the air conditioner stays at a well-ventilated place with no obstacles nearby that may obstruct the air inlet and outlet.
- (4) The installation location should be able to withstand the weight and vibration of air conditioner and allow the installation to be carried out safely.
- (5) Avoid installing at a place with leakage of inflammable gas, oil smoke or corrosive gas.
- (6) Keep it away from strong wind because strong wind will affect the condenser fan and lead to insufficient air flow volume and thus affecting the unit's performance.
- (7) Away from any object that may get the air conditioner generating noise.
- (8) Install the air conditioner at a place where condensate can be easily drained.
- (9) Do not install the air conditioner near the bedroom, otherwise the noise of the unit operation may disturbing to building occupants.
- (10) Do not install the air conditioner where water, ice or snow from overhang or roof may damage or flood the unit.

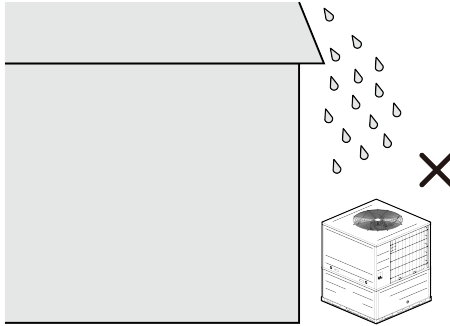

Fig.2

(11) Do not install the air conditioner in a corrosive environment, otherwise it may shorten the life, or negatively affect the performance of the unit.

(12) Installation requirements in snowy areas:

- a) Install the air conditioner on a stand which more than 20 in.(500mm) higher than the expected snow fall to prevent it from being covered by snow.
- b) Attach snow hood and snow guard.
- c) Do not install the air conditioner at a place where a snowdrift is generated.
- d) Remove the air inlet grille to prevent snow from accumulating on it.

Unit:inch(mm)

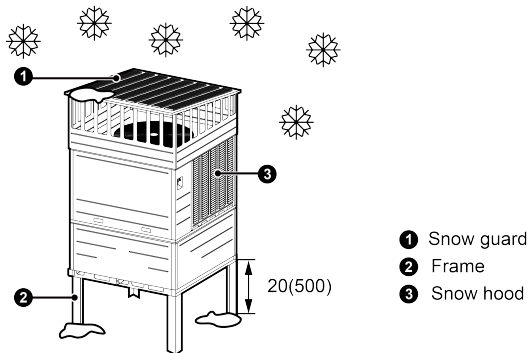

Fig.3

3.1.6 Physical Dimension

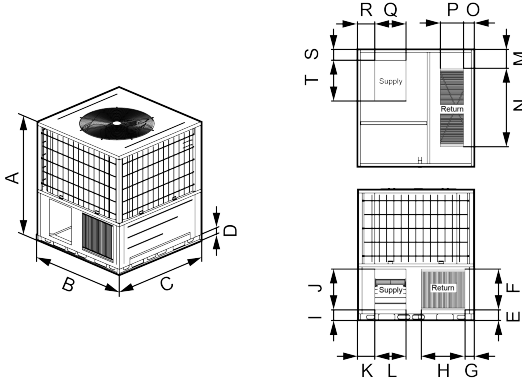

Fig.4

Unit:inch(mm)

Dimension	A	B	C	D				
KRH05TCU KRH04TCU	49-1/4 (1250)	44 (1120)	44 (1120)	2-1/2 (65)				
	Side air vents							
	E	size of air return		G	I	size of air supply		K
		F	H			J	L	
	4 (101)	15-3/8 (390)	16-1/2 (420)	3-3/8 (87)	4 (101)	15-3/8 (390)	11-3/4 (300)	6-1/2 (166)
	Bottom air vents							
	M	size of air return		O	R	size of air supply		S
		N	P			Q	T	
	7-7/8 (199)	28 (711)	9 (228)	3-3/4 (96)	6-1/2 (166)	11-3/4 (300)	15-3/8 (390)	4 (103)

Dimension	A	B	C	D				
KRH03TCU KRH02TCU	49-1/4 (1250)	44 (1120)	35-7/16 (900)	2-1/2 (65)				
	Side air vents							
	E	size of air return		G	I	size of air supply		K
		F	H			J	L	
	4-7/16 (113)	17-8/16 (445)	16-9/16 (420)	3-7/16 (87)	3-15/16 (101)	15-6/16 (390)	11-13/16 (300)	6-3/16 (157)
	Bottom air vents							
	M	size of air return		O	R	size of air supply		S
		N	P			Q	T	
	5-14/16 (149)	23-1/16 (586)	8-10/16 (219)	3-11/16 (93)	6-3/16 (156)	11-14/16 (302)	13-12/16 (350)	3-10/16 (92)

NOTE: Above diagrams may be different from actual mode.

3.1.7 Names of Main Parts

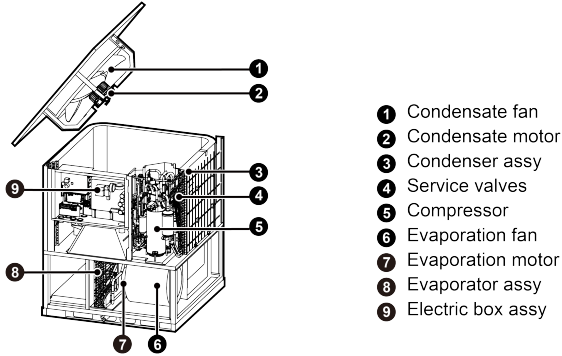

Fig.5

3.1.8 Diagram of Unit Installation Space and Location

Diagram of installation space and location (Notice: for best performance of the unit, make sure its installation space conforms to the following installation dimensions).

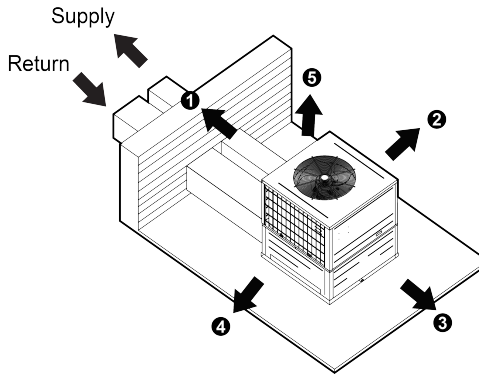

Fig.6

NOTE: Above diagrams may be different from actual model.

DIMENSION(Minimum)	Installation Clearances	
	inch	mm
1	24	610
2	8	203
3	20	508
4	24	610
5	60	1524

NOTE: Refer to local code requirements for additional clearance requirements.

3.2 Unit Installation

3.2.1 Curb-mounted installation

- ① Install curb.

NOTE: The manufacturer does not supply roof curb. Please refer to Figure 7 for roof curb reference dimensions.

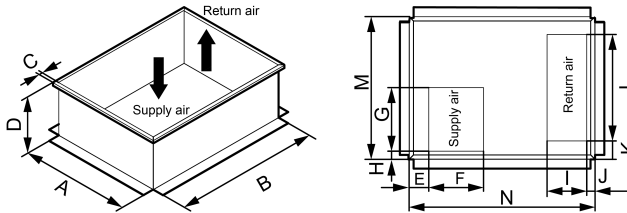

Fig.7
 KRH05TCU, KRH04TCU
 KRH03TCU, KRH02TCU

Unit:inch(mm)

Dimension	A	B	C	D	E
KRH05TCU	37-5/8	38-7/16	1	14	4-11/16
KRH04TCU	(956)	(976)	(25)	(356)	(119.5)
KRH03TCU	29	38-7/16	1	14	4-1/4
KRH02TCU	(736)	(976)	(25)	(356)	(109)

Dimension	F	G	H	I	J
KRH05TCU	11-13/16	15-3/8	2-3/16	8-3/4	2-3/16
KRH04TCU	(300)	(390)	(56)	(223)	(55)
KRH03TCU	11-7/8	13-3/4	1-3/4	8-5/8	1-3/4
KRH02TCU	(302)	(350)	(45)	(219)	(46)

Dimension	K	L	M	N
KRH05TCU	5-1/4	29-1/2	39-5/8	40-3/8
KRH04TCU	(133)	(750)	(1006)	(1026)
KRH03TCU	4	23	30-15/16	40-3/8
KRH02TCU	(102)	(586)	(786)	(1026)

- ② Field fabricate ductwork inside curb. Secure supply and return ducts to roof curb and building structure.
- ③ Rig and place unit.

- ④ Convert unit to vertical duct connection.
- ⑤ Install condensate drain piping.
- ⑥ Make electrical connections.

3.2.2 Pad-mounted installation

- ① Prepare pad and unit supports.
- ② Rig and place unit.
- ③ Convert unit to horizontal duct connection.
- ④ Field fabricate ductwork at unit duct openings.
- ⑤ Install condensate drain piping.
- ⑥ Make electrical connections.

3.2.3 Rigging and Lifting

Do not remove the unit's package materials before installation. Keep unit upright and do not drop. Rig the unit by attaching chain or cable slings to the lifting holes in base rails.

Place the unit on roof curb and maintain the clearance between the roof curb and the base rail inside at 1/4inch. (6.4mm)

After unit is position, remove rigging skids and package materials.

Unit:inch(mm)

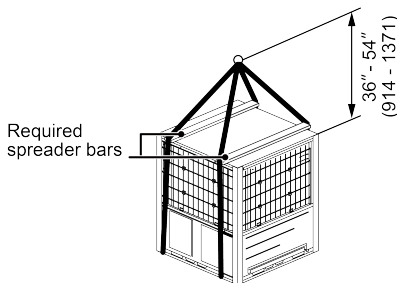

Fig.8

NOTICE

- | |
|---|
| (1) Spreader bars must required in order to prevent rigging straps from damaging unit. |
| (2) All panels must be in place when rigging. |
| (3) The height between the top of unit and the rigging cables' connection point should be 36-54inch (914-1371mm). |

3.2.4 Horizontal duct and Vertical duct conversation

To convert to horizontal duct configuration, remove screws from side duct opening covers (see Fig. 9) and remove covers.

To convert to vertical duct configuration, remove screws from basepan duct opening covers (see Fig. 10) and remove covers.

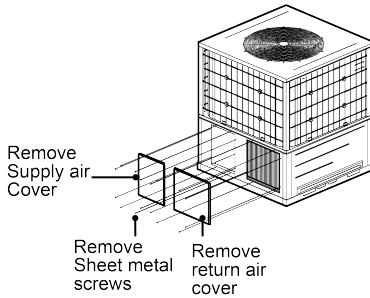

Fig.9 horizontal duct

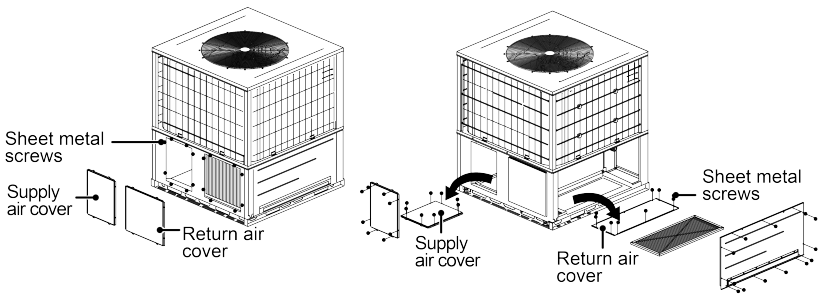

Fig.10 vertical duct

3.2.5 Installation of Condensate Pipe

- (1) Condensate drain side is pitched lower than the opposite side. (see Fig. 11)
- (2) When shipped out from factory, both the condensate outlets are blocked by rubber plug. So before installation, please take the rubber plug out.
- (3) Condensate removal is performed by attaching a PVC pipe to the drain pan and terminated in accordance with local or state Plumbing/HVAC codes.
- (4) The condensate pipe shall be installed with an inclining angel of 5~10°, so as to facilitate the drainage of condensate.

- (5) As the inside of the unit is in the negative pressure status, it is required to set up a backwater elbow. The requirements is: $A=B \geq P/10+20(\text{mm})$.P is the absolute pressure inside the unit. The unit of the pressure is Pa.
- (6) After the electrical installation is completed, carry out the testing of the drainage system.
- (7) It is not allowed to connect the condensate drain pipe into waste pipe or other pipelines which are likely to produce corrosive or peculiar smell to prevent the smell from entering indoors or corrupt the unit.
- (8) It is not allowed to connect the condensate drain pipe into rain pipe to prevent rain water from pouring in and cause property loss or personal injury.
- (9) Condensate drain pipe should be connected into special drain system for air conditioner.

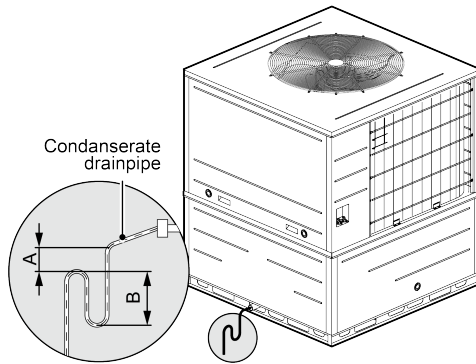

Fig.11

Model	Drain connection size(inch)
KRH05TCU	3/4"(NPT)
KRH04TCU	
KRH03TCU	
KRH02TCU	

3.2.6 Dip Switch Instruction

The unit can be connected to a wired controller or a thermostat, and only one of them can be connected. When the dip switch SA1 is 0000, the operation command of the wired controller is valid for the unit; When the dip switch SA1 is not 0000, the thermostat operation command is valid for the unit and it is not support to the unit

connected to the centralized controller.

The unit is equipped with a wired controller as standard, and the default setting of the dip switch SA1 is 0000. When it is necessary to replace the thermostat, the dip switch SA1 should be dialed according to the required speed when the air conditioner is powered off.

3.2.6.1 Fan Speed Adjustment Guidance

When the wired controller connected with the unit (dip switch SA1:0000), different static pressure levels can be adjusted, and the fan speeds of different static pressure levels are as follows:

Static pressure level	Super	High	Middle	Low
04	Speed 8	Speed 6	Speed 5	Speed 4
05	Speed 9	Speed 7	Speed 6	Speed 5
06	Speed 10	Speed 8	Speed 7	Speed 6
07	Speed 11	Speed 9	Speed 8	Speed 7
08	Speed 12	Speed 10	Speed 9	Speed 8
09	Speed 13	Speed 11	Speed 10	Speed 9

The default static pressure level from factory of the unit is 05, different static pressure levels can be adjusted according to the need. When the unit is off , pressing the "FUNCTION" and "TIMER" button at the same time for 5 seconds can enter the system debugging function. Then pressing the "MODE" button adjust the static pressure level to make the center of the wired controller's display interface show 11, and then pressing "▲" or "▼" button to show different numbers (01, 02, 03, 04, 05, 06, 07, 08, 09) on the lower right corner of the wired controller's display interface. After selecting the appropriate static pressure according to the required speed, the setting confirmed from pressing the "SWING/ENTER" button.

When the unit is connected to the thermostat, the dip switch SA1 is not 0000. Setting different positions of the dip switch is correspond to different speeds, and each combination is correspond to a speed. The relationship between combination and speeds are as follows:

Level	Dip switch SA1			
	4	3	2	1
Speed 4	0	1	0	0
Speed 5	0	1	0	1

Level	Dip switch SA1			
	4	3	2	1
Speed 6	0	1	1	0
Speed 7	0	1	1	1
Speed 8	1	0	0	0
Speed 9	1	0	0	1
Speed 10	1	0	1	0
Speed 11	1	0	1	1
Speed 12	1	1	0	0
Speed 13	1	1	0	1

NOTE: 0 means dip switch to 'on', 1 means dip switch to number.

3.2.6.2 Fan Performance Data

External static pressure should stay within the minimum and maximum limits shown in the table below in order to ensure proper operation of both cooling, heating, and electric heating operation.

Model	KRH05TCU, KRH04TCU								
	Static pressure:Inches W.C.(Pa)								
Level	0 (0)	0.1 (25)	0.2 (50)	0.3 (75)	0.4 (100)	0.5 (125)	0.6 (150)	0.7 (175)	0.8 (200)
Speed 4 (CFM)	1517	/	/	/	/	/	/	/	/
Speed 5 (CFM)	-	1464	/	/	/	/	/	/	/
Speed 6 (CFM)	-	1533	/	/	/	/	/	/	/
Speed 7 (CFM)	-	-	1517	/	/	/	/	/	/
Speed 8 (CFM)	-	-	1533	/	/	/	/	/	/
Speed 9 (CFM)	-	-	-	1525	/	/	/	/	/
Speed 10 (CFM)	-	-	-	-	1517	/	/	/	/
Speed 11 (CFM)	-	-	-	-	-	1558	1492	/	/
Speed 12 (CFM)	-	-	-	-	-	1566	1525	1480	/
Speed 13 (CFM)	-	-	-	-	-	1591	1538	1497	1470

Model	KRH03TCU, KRH02TCU								
	Static pressure:Inches W.C.(Pa)								
Level	0 (0)	0.1 (25)	0.2 (50)	0.3 (75)	0.4 (100)	0.5 (125)	0.6 (150)	0.7 (175)	0.8 (200)
Speed 4 (CFM)	1216	-	-	-	-	-	-	-	-
Speed 5 (CFM)	1293	-	-	-	-	-	-	-	-
Speed 6 (CFM)	1368	1264	-	-	-	-	-	-	-
Speed 7 (CFM)	1447	1348	1230	-	-	-	-	-	-
Speed 8 (CFM)	1501	1436	1327	1195	-	-	-	-	-
Speed 9 (CFM)	1506	1464	1417	1383	-	-	-	-	-
Speed 10 (CFM)	1498	1466	1423	1378	1280	-	-	-	-
Speed 11 (CFM)	1514	1472	1424	1385	1344	1303	-	-	-
Speed 12 (CFM)	1505	1467	1420	1375	1340	1303	1258	-	-
Speed 13 (CFM)	1510	1463	1424	1380	1340	1297	1258	1216	-

NOTE:

- ① ‘/’ denotes that the static pressure is out of range, air volume drop may affect the performance and reliability. Prohibition of use.
- ② ‘-’ denotes that the air volume is out of range, may lead to over-load and unstable operation of the fan motor. Prohibition of use.

3.3 Ductwork

This unit is designed for a complete supply and return ductwork system.

WARNING

Field ductwork must meet the National Fire Protection Association NFPA 90A, NFPA 90B and any applicable local ordinance.

Sheet metal ductwork run in unconditioned spaces must be insulated and covered with a vapor barrier. Fibrous ductwork may be used if constructed and installed in accordance with SMACNA Construction Standard on Fibrous Glass Ducts. Ductwork must comply with National Fire Protection Association as tested by U/L Standard 181 for Class I Air Ducts. Check local codes for requirements on ductwork and insulation.

Duct system must be designed within the range of external static pressure the unit is designed to operate against. It is important that the system airflow be adequate. Make sure supply and return ductwork, grills, special filters, accessories, etc. are accounted for in total resistance. See fan performance data in this manual.

Do not operate the unit without all ductwork completed.

Do not operate this product without all ductwork attached.

Inadequate ductwork that restricts airflow can result in improper performance and compressor or heater failure. Ductwork is to be constructed in a manner that limits restrictions and maintains suitable air velocity. Ductwork is to be sealed to the unit in a manner that will prevent leakage.

Return ductwork: Do not terminate the return ductwork in an area that can introduce toxic or objectionable fumes/odors into the ductwork. The return ductwork is to be introduced into the air handler bottom (up flow configuration).

Return Air Filters: Each installation must include a return air filter. This filtering may be performed at the air handler or externally such as a return air filter grille.

3.4 Electric Heater

The unit listed in this manual do not have factory installed electric heat. Electric heat is available as an accessory. Please refer to installation instructions provided with heater kit for the correct installation procedure.

⚠ WARNING Refer to the “Electric heater kits installation” section of this manual and the instructions provided with the heater kit for the correct installation procedure.

⚠ WARNING The electrical characteristics of the unit, the electric heater kit, and the supply power should be identical. This unit does not have factory installed electric heater. Electric heater is available as an accessory. If installing this option, the only heater kits that can be used are the series as indicated below. It is forbidden to use the electric heater other than those recommended.

⚠ WARNING Installation and debugging when attention to verify the switch sequence of electrical heating and fan, ensure the fan must be turned on when electric heating operation and ensure the electric heating is turned off before the fan to avoid unsafe.

⚠ WARNING Refer to the “Fan Performance Data” section of this manual,

otherwise it is possible to cause an exception and dry risk of electric heating.

⚠ WARNING The supply ducts that are 5 feet away from electric heating must be at least 1 feet away from other combustibles or walls.

3.4.1 Electric Heater Kits Available

SN.	Heater kit model	Code	Description	Ref. unit use(ton)
1	LYQ-08-A	320004060202	Circuit breaker, 5kW heat strip	2.0/3.0/4.0/5.0
2	LYQ-08-C	320004060200	Circuit breaker, 10kW heat strip	2.0/3.0/4.0/5.0
3	LYQ-08-D	320004060201	Circuit breaker, 15kW heat strip	4.0/5.0
4	LYQ-08-E	320004060204	Circuit breaker, 20kW heat strip	4.0/5.0

3.4.2 Electric Heater Kits Installation

⚠ CAUTION

- (1) Ensure that all power supply is disconnected prior to installing the heater kit.
- (2) A means of strain relief and conductor protection must be provided at the supply wire entrance into cabinet.
- (3) Use copper conductors only.
- (4) Installation must follow national electric code and other applicable codes.
- (5) If this appliance is installed in an enclosed area such as a garage or utility room with any carbon monoxide producing appliance, ensure the area is properly ventilated.
 - 1) Refer to the Table for appropriate heater kit.
 - 2) Check any physical damage, do not install damaged heater kit.
 - 3) Remove the access panel from unit.
 - 4) Remove cover plate from unit.
 - 5) Slide the heater kit in to the slot and secure element plate with previously removed screws.
 - 6) Insert power leads into the circuit breaker lugs.
 - 7) Connect ground wire to ground lug.

8) Knock off the hole in the stand column. If electric heater is not installed, do not knock off the holes; otherwise, may affect the performance and reliability.

9) Replace access panel and check operation.

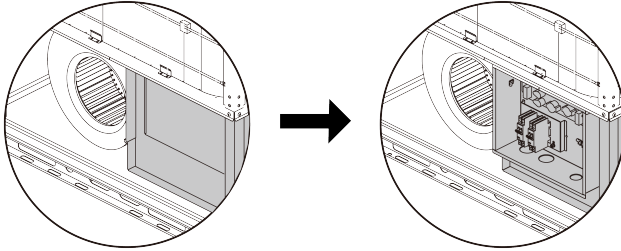

10) Connection of power cords and reserve lines.

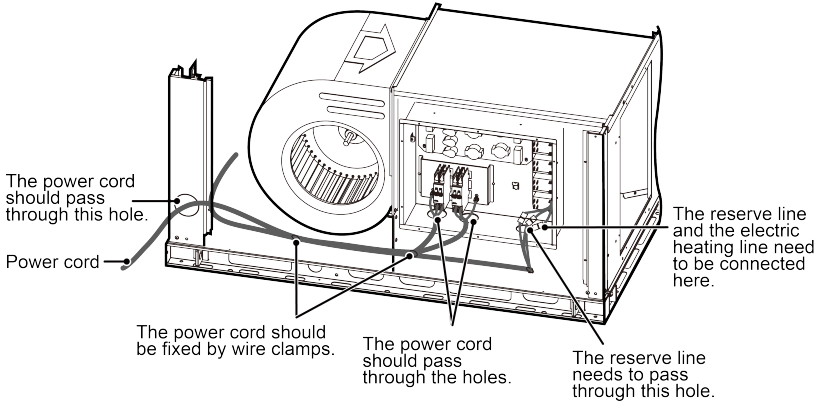

3.5 Electrical Installation

3.5.1 Electrical Parameters

Model	Power supply	Fuse capacity (A)	Maximum over-current protection(A)	Minimum circuit ampacity(A)
KRH05TCU KRH04TCU	208/230V-1Ph -60Hz	45	45	39.1
KRH03TCU KRH02TCU	208/230V-1Ph -60Hz	40	40	35

⚠ WARNING

The electrical installation for the air conditioner should observe the following requirements:

- ① The electrical installation must be conducted by professionals in compliance

with local laws and regulations and the instructions in this manual. The electric circuit must be equipped with a circuit breaker and air switch both with sufficient capacity.

- ② The unit's operating power must be within the nominal range stated in the instruction manual. Use a specialized power circuit for the air conditioner. Do not draw power from another power circuit.
- ③ The air conditioner circuit should be at least 1.5m away from any inflammable surface.
- ④ The external power cords, the wired controller wires (or the thermostat wires) and unit must be effectively fixed.
- ⑤ The external power cords, the wired controller wires (or the thermostat wires) and unit can't directly contact any hot objects. For example: they must not contact chimney pipes, warm gas pipes or other hot objects.
- ⑥ The external power cords, the wired controller wires (or the thermostat wires) and unit must not be squeezed. Never pull, stretch or bend the wires.
- ⑦ The external power cords, the wired controller wires (or the thermostat wires) and unit must not collide with any metal beam or edge on the ceiling, or touch any metal burrs or sharp metal edge around.
- ⑧ Connect wires correspondingly by referring to the circuit diagram labeled on the unit or electric box. Screws must be tightened up. Slipped screws must be replaced by specialized flat-head screws.
- ⑨ Wiring terminals should be connected firmly to the terminal board. Loose connection is forbidden.
- ⑩ The wire gauge of power cords should be large enough. Damaged power cords or other wires must be replaced by specialized wires. Wiring work must be done according to national wiring rules and regulations.
- ⑪ The unit has a heating four-way valve.

3.5.2 Connect Wiring to the Terminals

(1) For solid wires (as shown below):

- 1) Use wire cutters to cut off the wire end and then peel away about 25mm of the insulation layer.
- 2) Use a screwdriver to unscrew the terminal screw on the terminal board.
- 3) Use nippers to bend the solid wire into a ring that fits the terminal screw.

4)Form a proper ring and then put it on the terminal board. Use a screwdriver to tighten up the terminal screw.

(2) For strand wires (as shown below):

- 1)Use wire cutters to cut off the wire end and then peel away about 10mm of the insulation layer.
- 2)Use a screwdriver to unscrew the terminal screw on the terminal board.
- 3)Use a round terminal fastener or clamp to fix the round terminal firmly on the peeled wire end.
- 4)Locate the round terminal conduit. Use a screwdriver to replace it and tighten up the terminal screw (as shown below).

Unit:inch(mm)

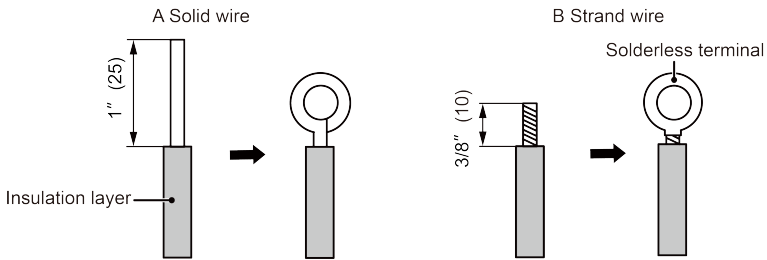

Fig.12

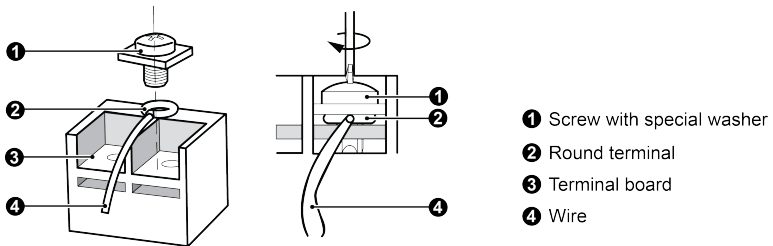

Fig.13

(3) How to connect the wired controller wires (or the thermostat wires) and power cords.

Lead the wired controller wires (or the thermostat wires) and power cords through the insulation tube (as shown in the following figure)

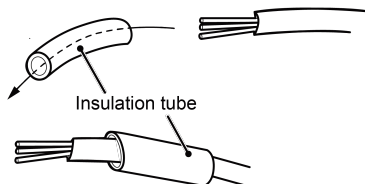

Fig.14

⚠ WARNING

- ① Before working, please check whether the units are powered on.
- ② Wrong wire connection may burn the electrical components.
- ③ Connect the wires firmly to the wiring box. Incomplete installation may lead to fire hazard.
- ④ Ground wire should be connected.

3.6 Wiring Diagram

Without electric heater

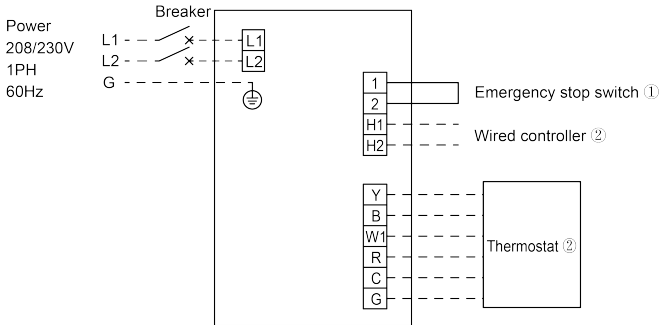

- Note:
- ① The factory has been short-circuited, when the user needs to connect the emergency stop switch, please remove the corresponding short-circuit wire
 - ② The unit can only be connected to a thermostat or wire controller

Fig.15

With electric heater

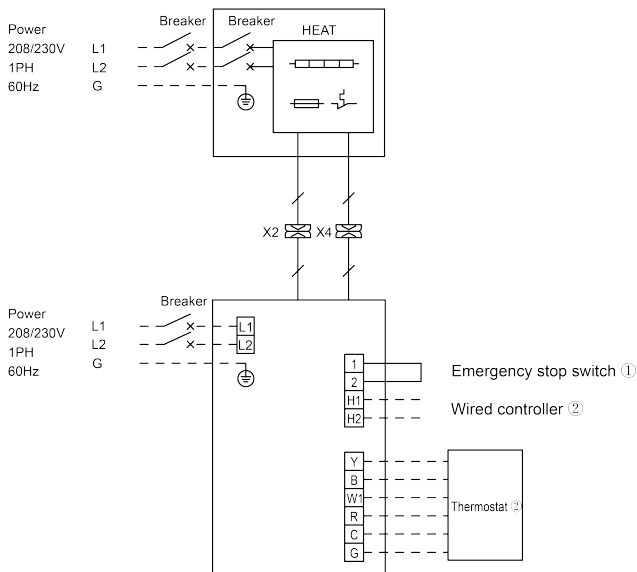

- Note: ① The factory has been short-circuited, when the user needs to connect the emergency stop switch, please remove the corresponding short-circuit wire
② The unit can only be connected to a thermostat or wire controller

Fig.16 (with LYQ-08-A,LYQ-08-C)

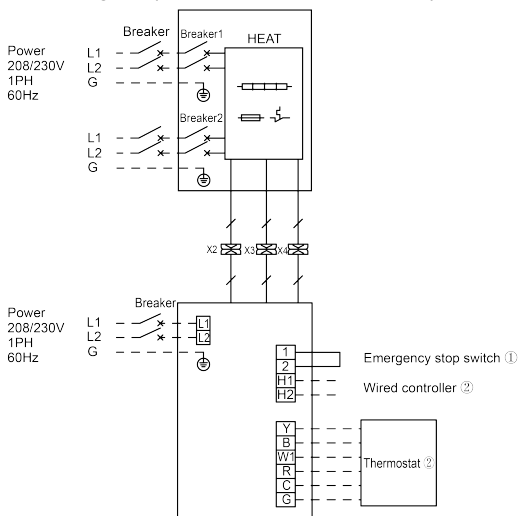

- Note: ① The factory has been short-circuited, when the user needs to connect the emergency stop switch, please remove the corresponding short-circuit wire
② The unit can only be connected to a thermostat or wire controller

Fig.17 (with LYQ-08-D,LYQ-08-E)

NOTE:

- ① The factory has been short-circuited, when the user needs to connect the emergency stop switch, please remove the corresponding short-circuit wire.
- ② The unit can only be connected to a thermostat or wired controller.

NOTE:

Y means Compressor control signal.

B which is energized under the heating mode means 4-way valve control signal.

W1 means heater control signal.

R means 24V AC power supply.

C means 24V common.

G means indoor side fan signal.

3.7 Engineering Wiring Diagram

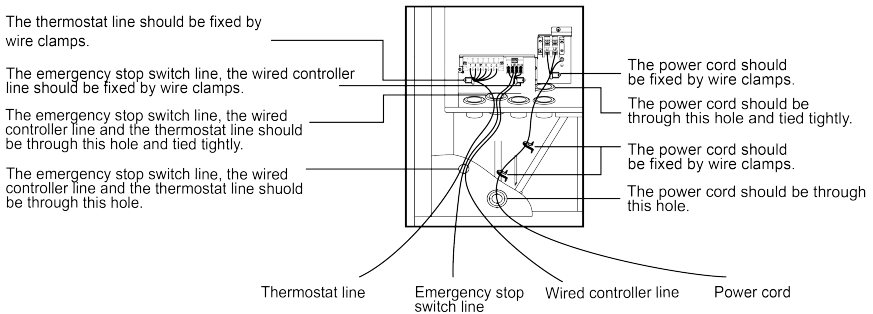

- Note: ① If there is no emergency stop switch, please ignore its wiring.
 ② The unit can only be connected to a thermostat or a wired controller.

Fig.18

KRH05TCU, KRH04TCU,
 KRH03TCU, KRH02TCU

3.8 Check after Installation

Check items	Possible events due to improper installation
Is the main body installed securely?	The unit may fall down, vibrate or produce noise.
Did you do water leakage test?	Cooling capacity may become unsatisfactory.
Is the unit well insulated from heat?	Condensate, water drops may occur.
Does water drainage go well?	Condensate, water drops may occur.

Check items	Possible events due to improper installation
Is the voltage consistent with that stated on the nameplate?	The unit may fail or its components may get burned.
Are the wires and pipes installed correctly?	The unit may fail or its components may get burned.
Has the unit been safely grounded?	Risk of electric leakage.
Do the specifications of wires comply with the requirement?	The unit may fail or its components may get burned.
Is there any obstacle blocking the air inlet and outlet of the units?	Cooling capacity may become unsatisfactory.

3.9 Test Running

Preparation before connecting the power:

- (1) Power must not be connected if the installation work is not completed.
- (2) Control circuit is correct and all the wires are firmly connected.
- (3) The inside of the unit should be clean. Take irrelevant objects out if there is any.

Operation after connecting the power:

- (1) If all the above works are finished, power on the unit.
- (2) If the outside temperature is more than 30°C, heating mode can't be enabled.
- (3) Before test operation, make sure unit is power on and compressor has been preheated for more than 8 hours. Touch the unit to check whether it's normally preheated. Start test operation after unit is normally preheated, otherwise compressor might be damaged. Debugging must be performed by professional technicians or under the guide of professional technicians.
- (4) Make sure the units can run normally.
- (5) If there's sound of liquid shock when the compressor is running, then stop the air conditioner immediately. Wait until the electric heating belt is heated enough, and then restart the air conditioner.

NOTICE

- ① If you use thermostat to turn off the unit and then immediately turn the unit on again, compressor will need 3min to restart. Even if you press "ON/OFF" button on the thermostat, it won't be started up right away.
- ② If there's no display on the thermostat, it's probably because the connection wires between the units and the thermostat are not connected. Please check again.

4 Troubleshooting

If your air-conditioning unit suffers from abnormal operation or failure, please first check the following points before repair.

Failure	Possible cause	Solution
The unit can not be started.	The power supply does not connect or improper phase sequence.	Connect the power supply or change two random phase.
	Electrical leakage of air-conditioning unit causes tripping of leakage switch.	Contact the nearest service center.
	The voltage is too low.	Contact the dealer.
	The control loop has failure.	Contact the nearest service center.
The unit operates for a while and then stops.	Air outlet port or intake port of the unit is blocked.	Remove the obstacles.
	There is obstacle in front of the condenser.	Remove the obstacles.
	The control loop is abnormal.	Contact the nearest service center.
Poor cooling effect.	Air filter is dirty.	Clean air filter.
	Air outlet port or intake port of indoor side or outdoor side is blocked.	Move the obstacles.
	Too many persons or a heat source in the Room.	If possible, clear heat sources.
	Doors or windows are open.	Close windows and doors.
	Refrigerant leakage.	Contact the nearest service center.
	Some model unit has a High Pressure Switch which is welded on discharge pipe. When the switch goes into effect, the power supply of compressor will be shut off.	Find and manual reset the High Pressure. Switch which is welded on discharge pipe.

NOTE: After carrying out the check of the above items and taking relevant measures to solve the problems found but the air-conditioning unit still does not function well, please stop the operation of the unit immediately and contact the nearest service center. Only ask professional serviceman to check and repair the unit.

5 Code List

No.	Code	Error or status
1	08	Defrosting
2	09	Oil return

No.	Code	Error or status
3	A0	Fan Drive module resetting
4	A1	Fan IPM module protection
5	A5	Inlet pipe temperature sensor of condenser error
6	A6	Malfunction from Fan driving part to main-control communication
7	A8	Overheat protection of Fan radiator
8	A9	Fan radiator sensor malfunction
9	AA	Fan AC current protection (input side)
10	Ac	Fan startup failure
11	Ad	Fan Missing phase
12	AE	Fan Current sensor malfunction
13	AF	Fan PFC abnormality
14	AH	Fan DC busbar over voltage protection
15	AJ	The Fan motor in loss of synchronization
16	AL	Fan DC busbar under voltage protection
17	An	Fan Drive Storage chip malfunction
18	AP	Fan AC input voltage abnormality
19	Ar	Fan driver board environment temperature sensor malfunction
20	AU	Fan Charge circuit malfunction
21	b2	Subcooler gas inlet temperature sensor error
22	b3	Subcooler gas outlet temperature sensor error
23	b4	Subcooler liquid outlet temperature sensor error
24	C4	Jumper failure(ODU)
25	C5	Jumper failure(IDU)
26	CA	Inlet pipe temperature sensor of evaporator error
27	Cb	Outlet pipe temperature sensor of evaporator error
28	CJ	Dip switch settings error
29	d1	DRED1 mode
30	d2	DRED2 mode
31	d3	DRED3 mode
32	dJ	Phase sequence protection
33	E1	Compressor high pressure protection
34	e1	High pressure sensor error
35	E2	Indoor anti-freeze protection
36	E3	Compressor low pressure protection

DC Inverter Rooftop Packaged Air Conditioner

No.	Code	Error or status
37	e3	Low pressure sensor error
38	E4	Compressor high discharge temperature protection
39	E6	Communication error
40	E8	Indoor fan motor error
41	EE	Outdoor memory chip error
42	ee	Drive memory chip error
43	EH	Electric heater operation error
44	EL	Emergency Stop(Fire alarm)
45	F0	Indoor ambient temperature sensor error
46	F1	Air outlet temperature sensor or mid temperature sensor of evaporator error
47	F2	Outlet pipe temperature sensor of condenser error
48	F3	Outdoor ambient temperature sensor error
49	F4	Discharge temperature sensor error
50	F5	Temperature sensor error of wired controller
51	F6	Mid temperature sensor of condenser error
52	H3	Compressor overload protection
53	H4	Overloading
54	H5	IPM protection
55	H6	DC fan motor error
56	H7	Drive desynchronizing protection
57	HC	PFC protection
58	Lc	Activation failure
59	Ld	Compressor phase sequence protection
60	LE	Compressor stalling protection
61	LF	Power protection
62	LP	Controllers incompatibility error
63	P0	Drive reset protection
64	P5	Over-current protection
65	P6	Communication error between main control and drive
66	P7	Drive module sensor error
67	P8	Drive module over temperature protection
68	P9	Zero passage protection
69	PA	AC current protection
70	Pc	Drive current error

No.	Code	Error or status
71	Pd	Sensor connecting protection
72	PE	Temperature drift protection
73	PF	Electric box sensor error
74	PH	Bus high voltage protection
75	PL	Bus low voltage protection
76	PP	Input voltage abnormality
77	PU	Charge loop error
78	U9	Fan AC contractor protection or input zero crossing error
79	Ud	Intelligent converter settings error
80	UL	Fan current protection
81	UP	Fan power protection

NOTE: If several errors happen at the same time, error codes will show on the display repeatedly.

6 Maintenance

To protract the life of the air-conditioning unit, check and maintain the unit regularly with a qualified service person.

6.1 Cleaning the Air Filter

- (1) Do not disassemble the air filter when cleaning it. Otherwise failure may be caused.
- (2) If the unit used in an dusty environment, It should clean the air filter more frequently.

6.2 Drainage Pipe

Periodically check if the drainage pipe is blocked to smooth the condensate water.

6.3 Cleaning the Heat Exchanger

Heat exchanger shall be cleaned regularly, which is at least once every two months. You can use a dust catcher with nylon brush to clean away the dust on the heat exchanger. If compressed air source is available, it also can be used to clean the heat exchanger. Do not clean it with water.

6.4 Notice before Seasonal Use

- (1) Check whether air inlets and air outlets of units are blocked.
- (2) Check whether ground connection is reliable or not.
- (3) Check whether air filter is properly installed.
- (4) If unit starts up after not operating for a long time, it should be power on 8 hours before operation starts so as to preheat the outdoor compressor.
- (5) Check whether unit is securely installed. If there is any problem, please contact Kinghome technical support.

6.5 Maintenance after Seasonal Use

- (1) Disconnect power of the entire system.
- (2) Clean the air filter and outer case of units.
- (3) Clean away the dust and obstacles.
- (4) If unit has rust, please apply some paint to it so as to prevent the rust from growing.

6.6 Parts Replacement

Parts and components can be obtained through contacting Kinghome technical support.

7 After-sales Service

If there's quality defect or other problems in the product, please contact Kinghome local Customer Service department for help.

Warranty must be based on the following conditions:

- (1) Product's initial startup must be performed by professional technicians assigned by Kinghome authorized dealer.
- (2) Only Kinghome spare parts are used.
- (3) All instructions of unit operation and maintenance in this manual must be strictly followed according to set period and set frequency.
- (4) Any breach of the above conditions will disable the warranty.



KINGHOME CANADA

Add: 40 Great Gulf Dr unit 39, Vaughan, ON L4K 0K7

Tel: +1 888-909-4835

E-mail: info@kinghomecanada.com

Web: www.kinghomecanada.com

For continuous improvement in the products, Kinghome reserves the right to modify the product specification and appearance in this manual without notice and without incurring any obligations.